

---

**User's  
Manual**

**Model LL200  
PC-based Custom  
Computation Building Tool  
User's Reference for UP750**



IM 05G01B22-03E

---



# Introduction

This user's manual provides descriptions of the computation modules, registers and other devices that are necessary when customizing the built-in computations and/or display functions using the LL200 PC-based Custom Computation Building Tool (hereinafter simply referred to as the LL200). Refer to this manual to familiarize yourself with the functions available in this tool or when you are not sure about the function of a particular module.

For details on the startup and operation of the LL200, see the Model LL200 PC-based Custom Computation Building Tool user's manual (IM 05G01B22-01E).

## ■ Intended Readers

This manual is intended for people familiar with the functions of the UP750 Digital Indicating Controller and capable of working with Windows, such as instrumentation and control engineers and personnel in charge of maintaining instrumentation and control equipment.

## ■ Related Documents

The following user's manuals all relate to the LL200. Read them as necessary. The codes enclosed in parentheses are the document numbers.

- **Model UP750 User's Manual for Single-loop Control (IM 05E01B02-01E to -07E)**  
Explains the basic operation of the UP750 controller. Supplied with the UP750.
- **GREEN Series User's Manual (Reference) (IM 05D01A02-01E)**  
Explains the functions of the GREEN Series controllers in detail. Supplied with each GREEN Series model.
- **GREEN Series Communication Functions (IM 05G01B02-01E)**  
Explains the communication functions and communication protocols of the GREEN Series in detail. Supplied with each GREEN Series model with communication capability.
- **GREEN Series Communication Reference (IM 05G01B02-02E)**  
Provides detailed information about GREEN Series controller's internal registers that can be accessed by communication. Supplied with each GREEN Series model with communication capability.
- **Model LL100 PC-based Parameters Setting Tool (IM 05G01B12-01E)**  
A user's manual for setting the parameters of the GREEN Series from a personal computer. Supplied with the LL100 PC-based Parameters Setting Tool and LL200 PC-based Custom Computation Building Tool.
- **Model LL200 PC-based Custom Computation Building Tool (IM 05G01B22-01E)**  
A user's manual for creating GREEN Series custom computations on a personal computer. Supplied with the LL200 PC-based Custom Computation Building Tool.

# Documentation Conventions

## ■ Symbols Used in This Manual

The following symbols are used in this manual.

### ● Symbols Used in the Main Text



#### **Warning:**

Indicates that operating the hardware or software in this manner may damage it or lead to system failure.



#### **NOTE**

Draws attention to information that is essential to understanding the operation and/or features of the product.

#### **TIP**

Gives additional information to complement the present topic.

#### **See Also**

Gives reference locations for further information on the topic.

### ● Symbols Used in Figures and Tables

#### **[NOTE]**

Draws attention to information that is essential to understanding the features of the product.

#### **[TIP]**

Gives additional information to complement the present topic.

#### **[See Also]**

Gives reference locations for further information on the topic.

## ■ Description of Displays

- (1) Some of the representations of product displays shown in this manual may be exaggerated, simplified, or partially omitted for reasons of convenience when explaining them.
- (2) Figures and illustrations representing the controller's displays may differ from the real displays in regard to the position and/or indicated characters (upper-case or lower-case, for example), to the extent that they do not impair a correct understanding of the functions and the proper operation and monitoring of the system.

# Notices

## ■ Regarding This User's Manual

- (1) This manual should be passed on to the end user. Keep at least one extra copy of the manual in a safe place.
- (2) Read this manual carefully to gain a thorough understanding of how to operate this product before you start using it.
- (3) This manual is intended to describe the functions of this product. Yokogawa Electric Corporation (hereinafter simply referred to as Yokogawa Electric) does not guarantee that these functions are suited to the particular purpose of the user.
- (4) Under absolutely no circumstance may the contents of this manual, in part or in whole, be reproduced or copied without permission.
- (5) The contents of this manual are subject to change without prior notice.
- (6) Every effort has been made to ensure accuracy in the preparation of this manual. Should any errors or omissions come to your attention however, please contact your nearest Yokogawa representative or our sales office.

## ■ Regarding Protection, Safety, and Prohibition Against Unauthorized Modification

- (1) In order to protect the product and the system controlled by it against damage and ensure its safe use, make certain that all of the instructions and precautions relating to safety contained in this document are strictly adhered to. Yokogawa Electric does not guarantee safety if products are not handled according to these instructions.
- (2) The following safety symbols are used on the product and/or in this manual.

### ● Symbols Used on the Product and in This Manual



This symbol on the product indicates that the operator must refer to an explanation in the user's manual in order to avoid the risk of injury or loss of personnel or damage to the instrument. The manual describes how the operator should exercise special care to avoid electric shock or other dangers that may result in injury or loss of life.



This symbol indicates that the terminal must be connected to ground prior to operating the equipment.



This symbol indicates that the terminal must be connected to ground prior to operating the equipment.

## ■ Force Majeure

- (1) Yokogawa Electric assumes no liability to any party for any loss or damage, direct or indirect, caused by the use or any unpredictable defect of the product.
- (2) Be sure to use the spare parts approved by Yokogawa Electric when replacing parts or consumables.
- (3) Modification of the product is strictly prohibited.
- (4) Use this software with one specified computer only. You must purchase another copy of the software for use on each additional computer.
- (5) Copying this software for purposes other than backup is strictly prohibited.
- (6) Store the floppy disk(s) (original medium or media) containing this software in a secure place.
- (7) Reverse engineering such as the disassembly or decompilation of software is strictly prohibited.
- (8) No portion of the software supplied by Yokogawa Electric may be transferred, exchanged, leased or sublet for use by any third party without the prior permission of Yokogawa Electric.

---

Blank Page



**Model LL200**  
**PC-based Custom Computation Building Tool**  
**User's Reference for UP750**

IM 05G01B22-03E 6th Edition

# CONTENTS

- Introduction ..... i
- Documentation Conventions ..... ii
- Notices ..... iii
- 1. Overview ..... 1-1
- 2. Computation Block Diagrams for Individual UP Modes ..... 2-1
  - 2.1 Input/Output Blocks for Single-loop Control (UP Mode 1) ..... 2-5
  - 2.2 Input/Output Blocks for Cascade Primary-loop Control (UP Mode 2) ..... 2-6
  - 2.3 Input/Output Blocks for Cascade Control (UP Mode 4) ..... 2-7
  - 2.4 Input/Output Blocks for Loop Control with PV Switching (UP Mode 6) ..... 2-8
  - 2.5 Input/Output Blocks for Loop Control with PV Auto-selector (UP Mode 7) . 2-9
  - 2.6 Input/Output Blocks for Dual-loop Control (UP Mode 11) ..... 2-10
  - 2.7 Input/Output Blocks for Temperature and Humidity Control (UP Mode 12) ... 2-11
  - 2.8 Input/Output Blocks for Cascade Control with Two Universal Inputs (UP Mode 13) ..... 2-12
  - 2.9 Input/Output Blocks for Loop Control with PV Switching and Two Universal Inputs (UP Mode 14) ..... 2-13
  - 2.10 Input/Output Blocks for Loop Control with PV Auto-selector and Two Universal Inputs (UP Mode 15) ..... 2-14
- 3. Types and Ranges of Computation Data ..... 3-1
  - 3.1 Types of Computation Data ..... 3-2
  - 3.2 Data Fed to the Input Block ..... 3-3
  - 3.3 Data Fed from the Input Block ..... 3-4
  - 3.4 Data Fed to the Output Block ..... 3-8
  - 3.5 Data Fed from the Output Block ..... 3-10
- 4. List of Computation Modules and Their Functions ..... 4-1
  - 4.1 How to Hold Outputs at Power Failure and Recovery Using Custom Computation ..... 4-2
  - 4.2 List of Computation Modules ..... 4-3
  - 4.3 Explanation of Computation Modules ..... 4-7
    - 1 Addition ..... 4-7
    - 2 Subtraction ..... 4-8
    - 3 Multiplication ..... 4-8
    - 4 Division ..... 4-9
    - 5 Absolute Value ..... 4-9
    - 6 Reciprocal ..... 4-10

---

7	Auto Selector (Min./Max./Average/Difference) .....	4-11
8	Hold Maximum Value .....	4-12
9	Hold Minimum Value .....	4-13
10	Hold .....	4-14
11	Switch .....	4-14
12	Limiter .....	4-15
13	Constant .....	4-16
14	AND Logic .....	4-17
15	OR Logic .....	4-18
16	XOR Logic .....	4-19
17	NOT Logic .....	4-20
18	Latch .....	4-21
19	Greater-than Logic .....	4-22
20	Less-than Logic .....	4-23
21	Decremental Counter .....	4-24
22	Counter .....	4-26
23	Equal-to Logic .....	4-28
24	Not-Equal-to Logic .....	4-29
25	Range Logic .....	4-30
26	Delay Logic .....	4-31
27	AND (Long Word) Logic .....	4-32
28	OR (Long Word) Logic .....	4-33
29	Word Shift .....	4-34
30	Sum .....	4-35
31	Timer .....	4-36
32	Rate-of-change Limiter .....	4-38
33	10-segment Linearizer 1 .....	4-39
34	10-segment Linearizer 2 .....	4-40
35	Inverse 10-segment Linearizer 1 Approximation .....	4-41
36	Inverse 10-segment Linearizer 2 Approximation .....	4-42
37	Curve Linearizer 1 Approximation .....	4-43
38	Curve Linearizer 2 Approximation .....	4-44
39	Ratio .....	4-45
40	First-order-lag Filter .....	4-46
41	EU Range Conversion .....	4-47
42	Switching Between 2 Inputs .....	4-48
43	Temperature and Humidity Calculation .....	4-50
44	Square Root Extraction .....	4-51
45	Detection of Change .....	4-52
46	Loop 1 Output Selection 1 .....	4-53
47	Loop 1 Output Selection 11 .....	4-54
48	Loop 1 Output Selection 12 .....	4-54

---

49	Loop 1 Output Selection 13 .....	4-55
50	Loop 1 Output Selection 14 .....	4-55
51	Loop 2 Output Selection 2 .....	4-56
52	Loop 2 Output Selection 21 .....	4-57
53	Loop 2 Output Selection 22 .....	4-57
54	Loop 2 Output Selection 23 .....	4-58
55	Display Data Unit Conversion .....	4-59
56	Parameter Setting .....	4-60
57	Data Display 1 .....	4-61
58	Data Display 2 .....	4-62
59	Special DO Output .....	4-63
60	Output 1 Terminal Configuration .....	4-64
61	Output 2 Terminal Configuration .....	4-64
62	Fluid Temperature Compensation .....	4-65
63	Fluid Pressure Compensation .....	4-66
64	10-segment Linearizer 3 Approximation .....	4-67
65	10-segment Linearizer 4 Approximation .....	4-68
67	Dead Time .....	4-69
68	Moving Average .....	4-70
69	Multi-selector .....	4-71
70	Edge-triggered Counter .....	4-72
71	Edge-triggered Timer .....	4-74
72	Detection of Change at Edge .....	4-76
73	Square Root Extraction 2 .....	4-77
74	Flow Sum .....	4-78
75	Integrated Pulse Output .....	4-80
76	BCD Conversion .....	4-81
77	XOR (Long Word) Logic .....	4-82
78	Data Save .....	4-83
<b>5.</b>	<b>UP750 Data Storage Areas (D Registers and I Relays).....</b>	<b>5-1</b>
<b>5.1</b>	<b>Configuration of UP750 Data Storage Areas .....</b>	<b>5-2</b>
<b>5.2</b>	<b>Input Block Data Storage Area (D Registers 1301 to 1500).....</b>	<b>5-4</b>
5.2.1	Area for Storing Data Fed to the Input Block .....	5-5
5.2.2	Area for Storing Data Fed from the Input Block .....	5-5
5.2.3	Area for Storing Output Data of Input Block Computation Modules....	5-5
<b>5.3</b>	<b>Output Block Data Storage Area (D Registers 1501 to 1700).....</b>	<b>5-6</b>
5.3.1	Area for Storing Data Fed to the Output Block.....	5-7
5.3.2	Area for Storing Data Fed from the Output Block.....	5-7
5.3.3	Area for Storing Output Data of Output Block Computation Modules.....	5-7
<b>5.4</b>	<b>Process Data Area and User Area (D Registers 1 to 100) .....</b>	<b>5-8</b>
5.4.1	Process Data Area (Read-only Data) .....	5-9
5.4.2	User Area .....	5-18

<b>5.5</b>	<b>Area for Operation Program data (D Registers 101 to 200)</b> .....	<b>5-19</b>
5.5.1	Program Data Area .....	5-20
<b>5.6</b>	<b>Operation Mode and Computation Parameters (D Registers 201 to 300)</b> ..	<b>5-21</b>
5.6.1	Operation Mode Information .....	5-22
5.6.2	Write-only Data Area .....	5-22
5.6.3	Data Area for Computation Parameters .....	5-23
<b>5.7</b>	<b>Loop 1 PID Parameters (D Registers 301 to 500)</b> .....	<b>5-24</b>
5.7.1	Data Area for Loop 1 PID Parameters .....	5-25
<b>5.8</b>	<b>Loop 2 PID Parameters (D Registers 501 to 700)</b> .....	<b>5-26</b>
5.8.1	Data Area for Loop 2 PID Parameters .....	5-27
<b>5.9</b>	<b>USER Parameters, 10-segment Linearizer Parameters, and Messages (D Registers 701 to 900)</b> .....	<b>5-28</b>
5.9.1	Data Area for USER Parameters .....	5-29
5.9.2	Data Area for Parameters of 10-segment Linearizers 1 and 2 .....	5-29
5.9.3	Area for Setting Message Text .....	5-29
<b>5.10</b>	<b>Control Action, Loop-common Function, and I/O Configuration Parameters (D Registers 901 to 1200)</b> .....	<b>5-30</b>
5.10.1	Data Area for Control Action Parameters .....	5-31
5.10.2	Data Area for Loop-common Function Parameters .....	5-31
5.10.3	Data Area for Saving Module Outputs .....	5-31
5.10.4	Data Area for I/O Configuration Parameters .....	5-31
<b>5.11</b>	<b>Controller Mode (UP mode), PV Input, and Control Output Parameters (D Registers 1201 to 1300)</b> .....	<b>5-32</b>
5.11.1	Data Area for Controller Mode (UP mode), PV Input, and Control Output Parameters .....	5-33
<b>5.12</b>	<b>Status Area (I Relays 1 [5001] to 192 [5192])</b> .....	<b>5-34</b>
5.12.1	Area for Status I Relays .....	5-35
<b>5.13</b>	<b>ON Status I Relays (I Relays 193 [5193] to 384 [5384])</b> .....	<b>5-36</b>
5.13.1	Area for ON Status I Relays .....	5-37
<b>5.14</b>	<b>OFF Status I Relays (I Relays 385 [5385] to 576 [5576])</b> .....	<b>5-38</b>
5.14.1	Area for OFF Status I Relays .....	5-39
<b>5.15</b>	<b>Status I Relays for Alarm Flag, Timer Flag, Power-on Flag, and Others (I Relays 577 [5577] to 2048 [7048])</b> .....	<b>5-40</b>
5.15.1	Status I Relays for Alarm Flag, Timer Flag, Power-on Flag, and Others ..	5-41
5.15.2	User Area .....	5-42
5.15.3	Timer Function .....	5-42
<b>6.</b>	<b>Operating Display Functions</b> .....	<b>6-1</b>
6.1	List of Operating Displays and Their Descriptions .....	6-2
6.2	Non-displaying Conditions for Operating Displays .....	6-5
6.3	Display Switching Conditions for Operating Displays .....	6-6
<b>Revision Information</b> .....		<b>1</b>

# 1. Overview

First read the LL200 PC-based Custom Computation Building Tool user's manual to familiarize yourself with the basic operation of the LL200 and examples of custom computations. Then, read this manual when you actually configure your own custom computations and display functions.

This manual explains the computation modules you will use when customizing the built-in computations with the LL200 PC-based Custom Computation Building Tool. It also discusses the operating display functions you will use when configuring customized display functions. See the following summary for information on what each chapter discusses and for what purpose it is written.

## ■ Information and Purpose Covered by Each Chapter

### ● Chapter 2 Computation Block Diagrams for Individual UP Modes

Shows the diagrams of the UP750's standard computation blocks that can be customized (i.e. the input block and output block). See this chapter when you configure custom computations by modifying the standard computation blocks supplied as the LL200's sample files. A single look at these diagrams allows you to easily understand the computation blocks for controller modes (UP modes) 1 to 15.

### ● Chapter 3 Types and Ranges of Computation Data

Lists the types and ranges of signals coming in and going out of input and output blocks. See this chapter when configuring custom computations because you must verify the types and ranges of signals that apply to the blocks.

### ● Chapter 4 List of Computation Modules and Their Functions

Explains the functions of the computation modules in detail, along with the number of inputs and the data types used in each computation module. See this chapter when you want to know the functions of modules you will use when creating custom computations.

### ● Chapter 5 UP750 Data Storage Areas (D Registers and I Relays)

Explains the data items stored in the UP750 controller.

These data items can be linked to the input and output terminals of the computation modules. They also include process data, parameter data and flag data. See this chapter when creating custom computations.

### ● Chapter 6 Operating Display Functions

Lists operating display patterns, along with their display contents. See this chapter when you configure operating display functions.

---

Blank Page

## 2. Computation Block Diagrams for Individual UP Modes

This chapter describes the UP750's customizable computation blocks (more specifically, the input/output blocks shown in Figure 2.3) for the standard controller modes (UP modes).



Since this chapter lists the input/output blocks for all the standard controller modes (UP modes 1 to 15), you can refer to this chapter when configuring custom computations using the LL200's sample files.

Figure 2.3 shows the whole view of the UP750's functional structure, focusing on the input/output blocks and signals that go in and out of the input/output blocks. This figure thus clarifies where the input and output blocks are positioned within the functionality of the UP750.

Figures 2.4 and after are diagrams of the input and output blocks for each controller mode (UP mode).

## ■ Symbols and Names Used in UP750 Function Block Diagram

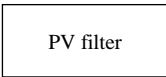
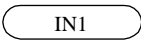
Names and symbols used in the UP750 function block diagram are as summarized below:

	This symbol represents a function, and in this example means a PV filter.
	This symbol represents a parameter (setup or operation parameter), and in this example means analog input 1 type [IN1].
	This symbol represents a signal fed to or from the input or output block, and in this example means a signal fed to an input block [AIN1].

020001E.EPS

### See Also

The UP750 User's Manual for Single-loop Control (IM 05E01B02-01E to -07E) for the function names and the parameters; and Chapter 3 of this manual, "Types and Ranges of Computation Data," for custom computation I/O signals.



# Symbols and Numbers Used in Computation Block Diagrams

## • Diagram for Input Block

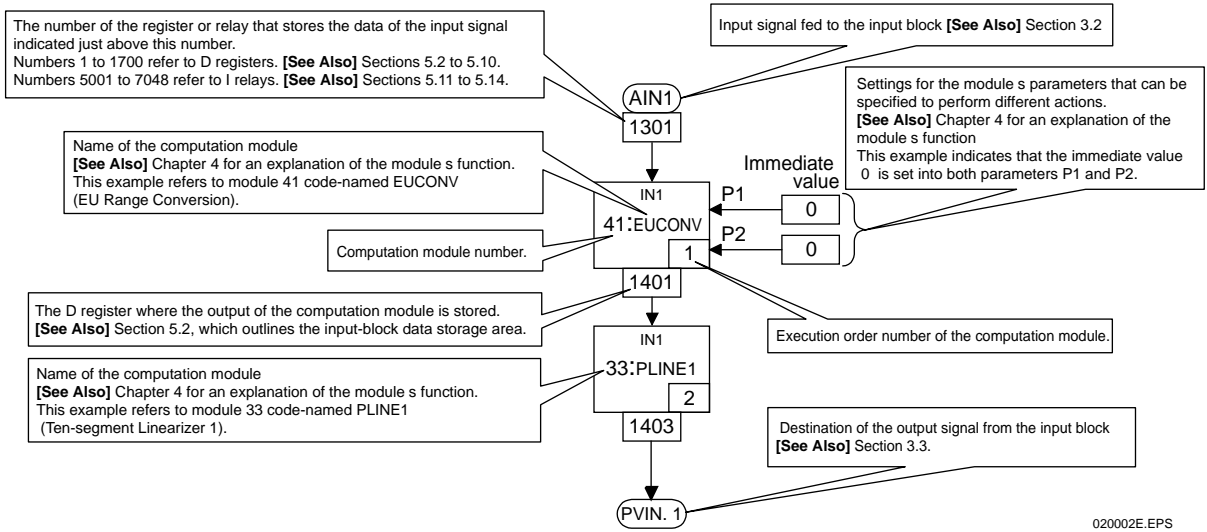

Figure 2.1 Explanation of an Input Block Diagram

## • Diagram for Output Block

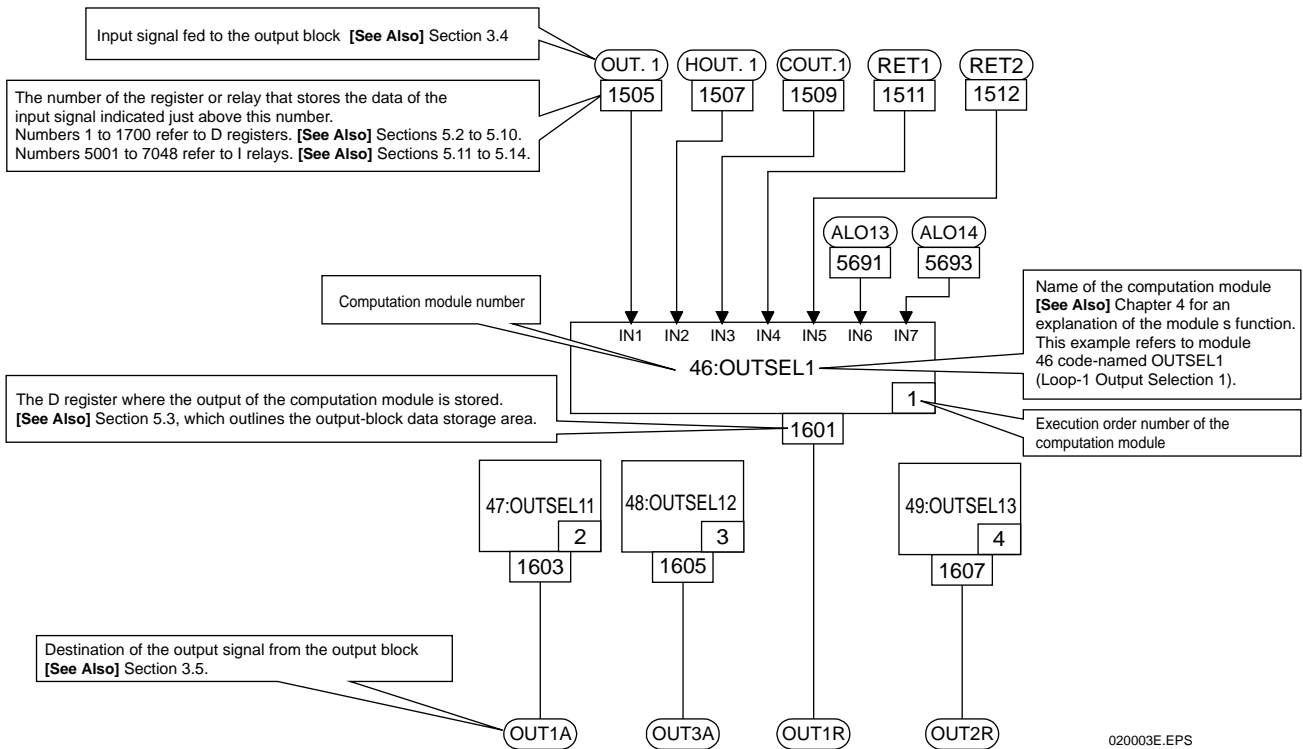

Figure 2.2 Explanation of an Output Block Diagram

■ Function Block Diagram of UP750 (Whole View)

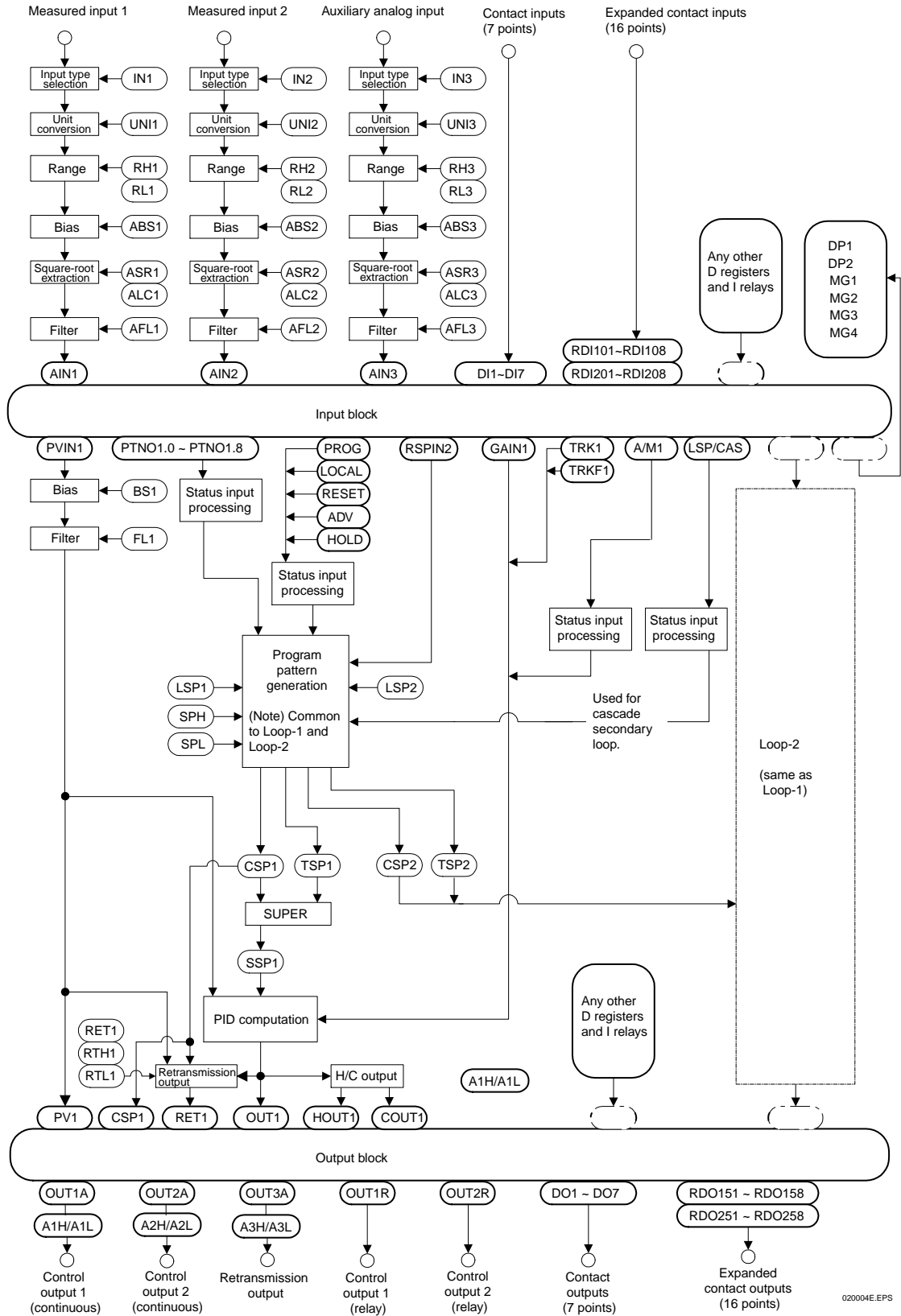

Figure 2.3 Function Block Diagram of UP750 (Whole View)

# 2.1 Input/Output Blocks for Single-loop Control (UP Mode 1)

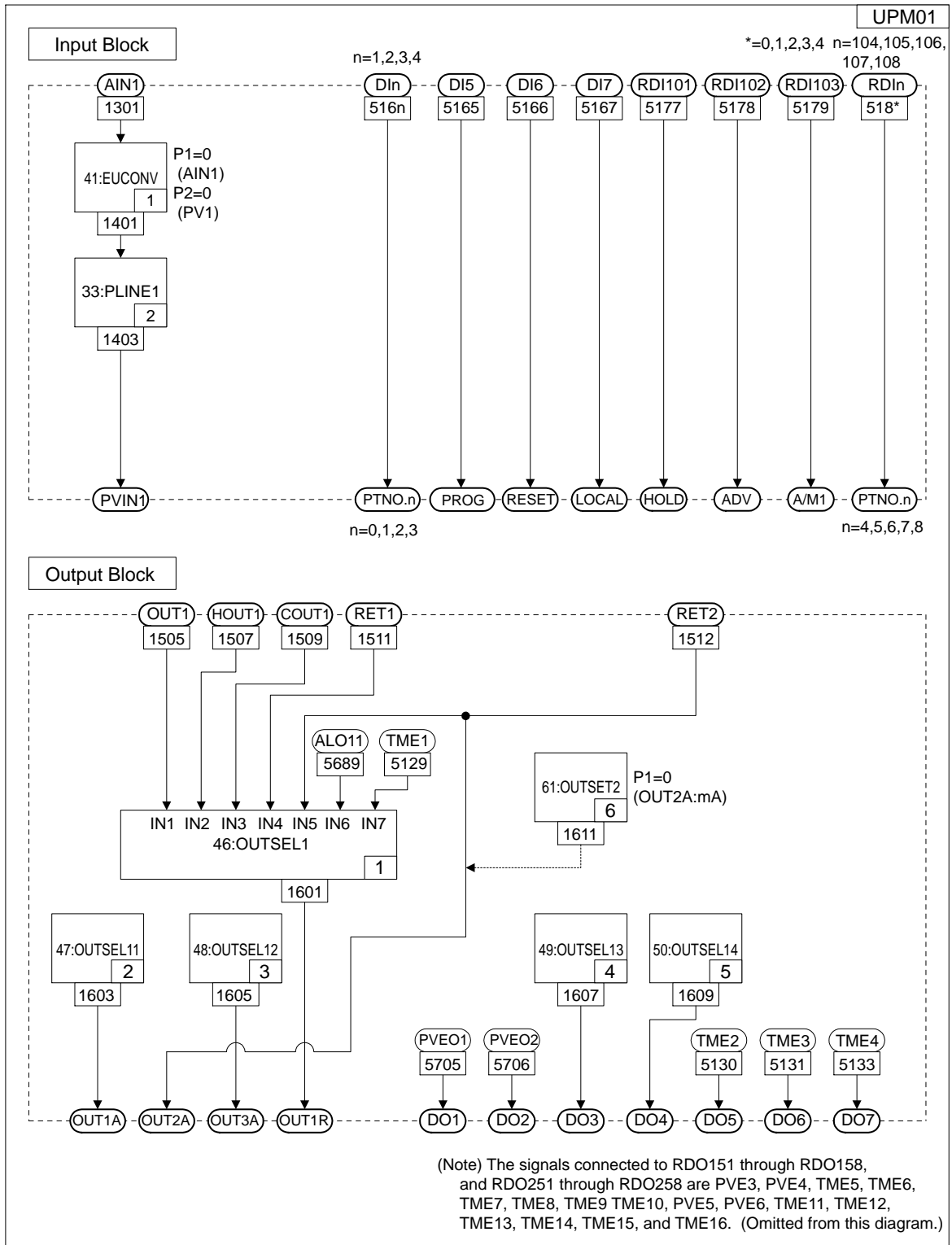

Figure 2.4 Input and Output Blocks for Single-loop Control (UP Mode 1)

# 2.2 Input/Output Blocks for Cascade Primary-loop Control (UP Mode 2)

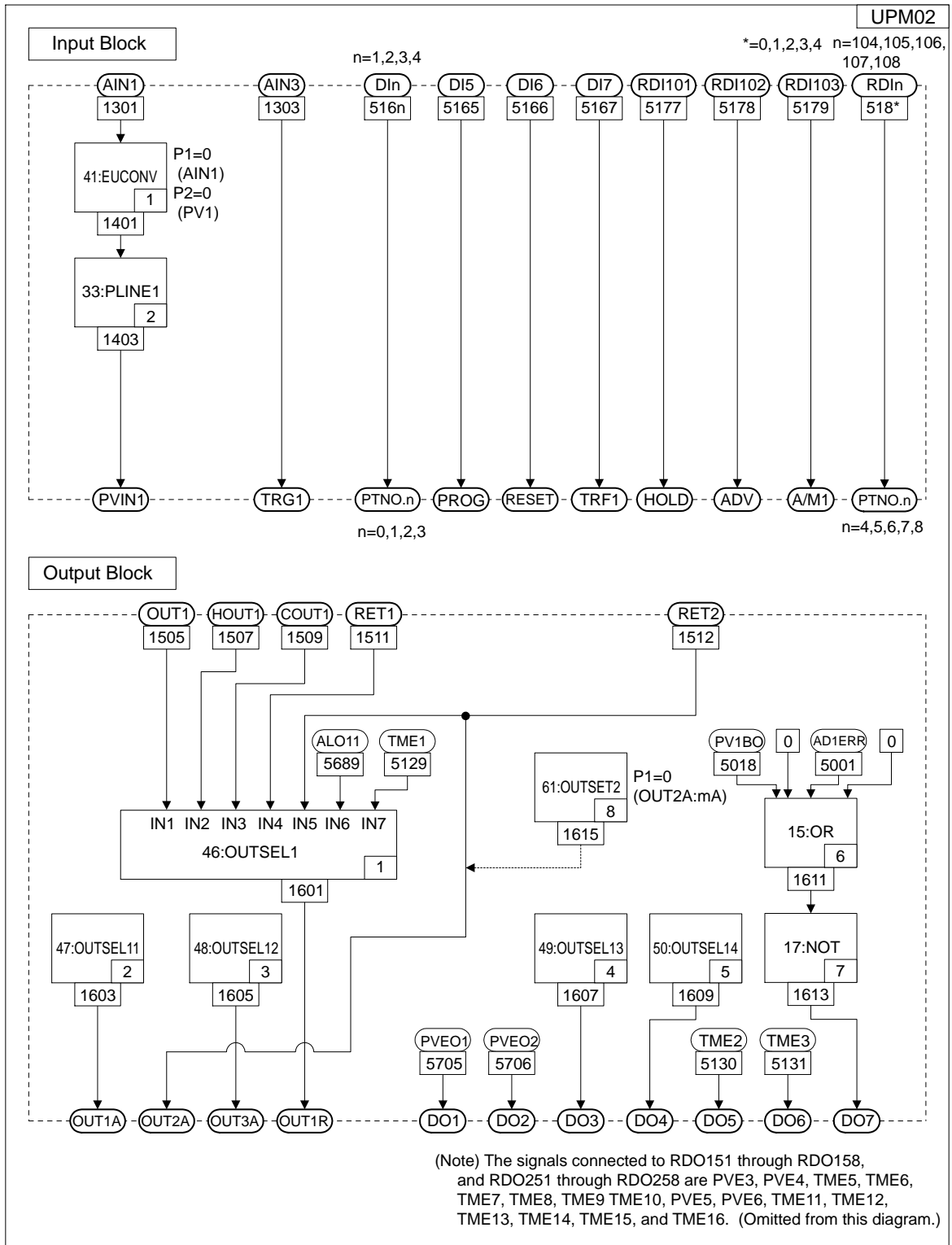

Figure 2.5 Input and Output Blocks for Cascade Primary-loop Control (UP Mode 2)

# 2.3 Input/Output Blocks for Cascade Control (UP Mode 4)

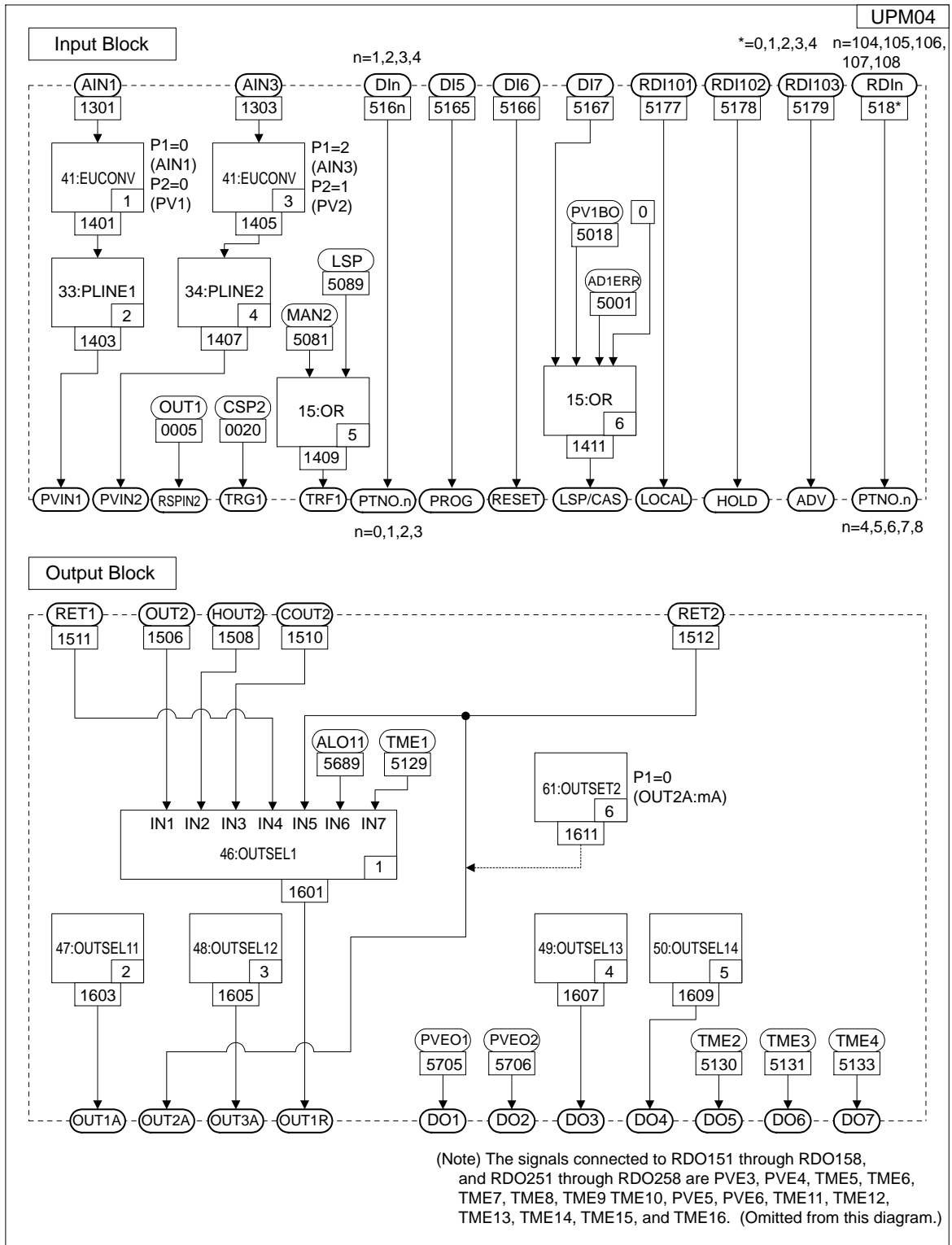
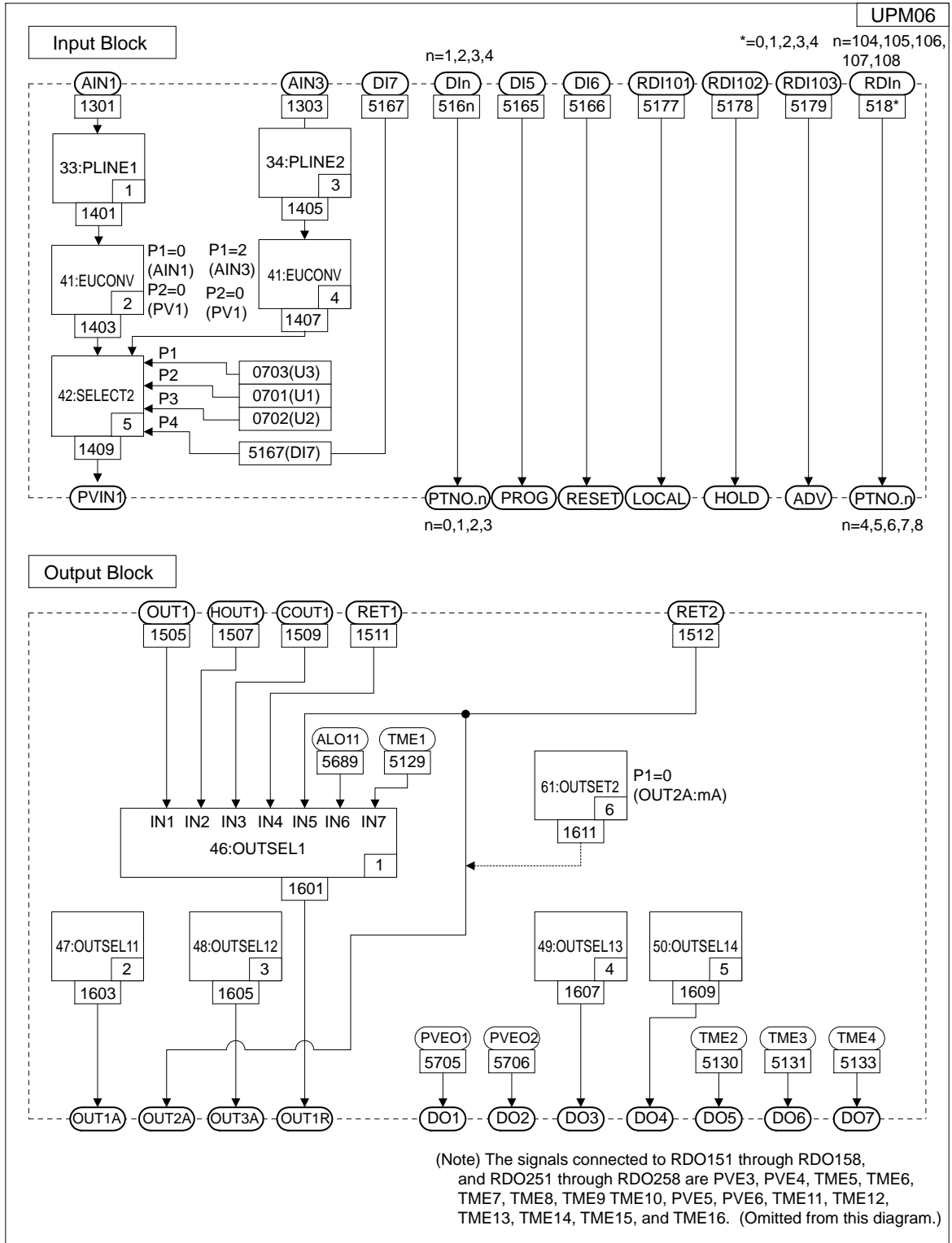

Figure 2.6 Input and Output Blocks for Cascade Control (UP Mode 4)

# 2.4 Input/Output Blocks for Loop Control with PV Switching (UP Mode 6)



020401E.EPS

Figure 2.7 Input and Output Blocks for Loop Control with PV Switching (UP Mode 6)

## 2.5 Input/Output Blocks for Loop Control with PV Auto-selector (UP Mode 7)

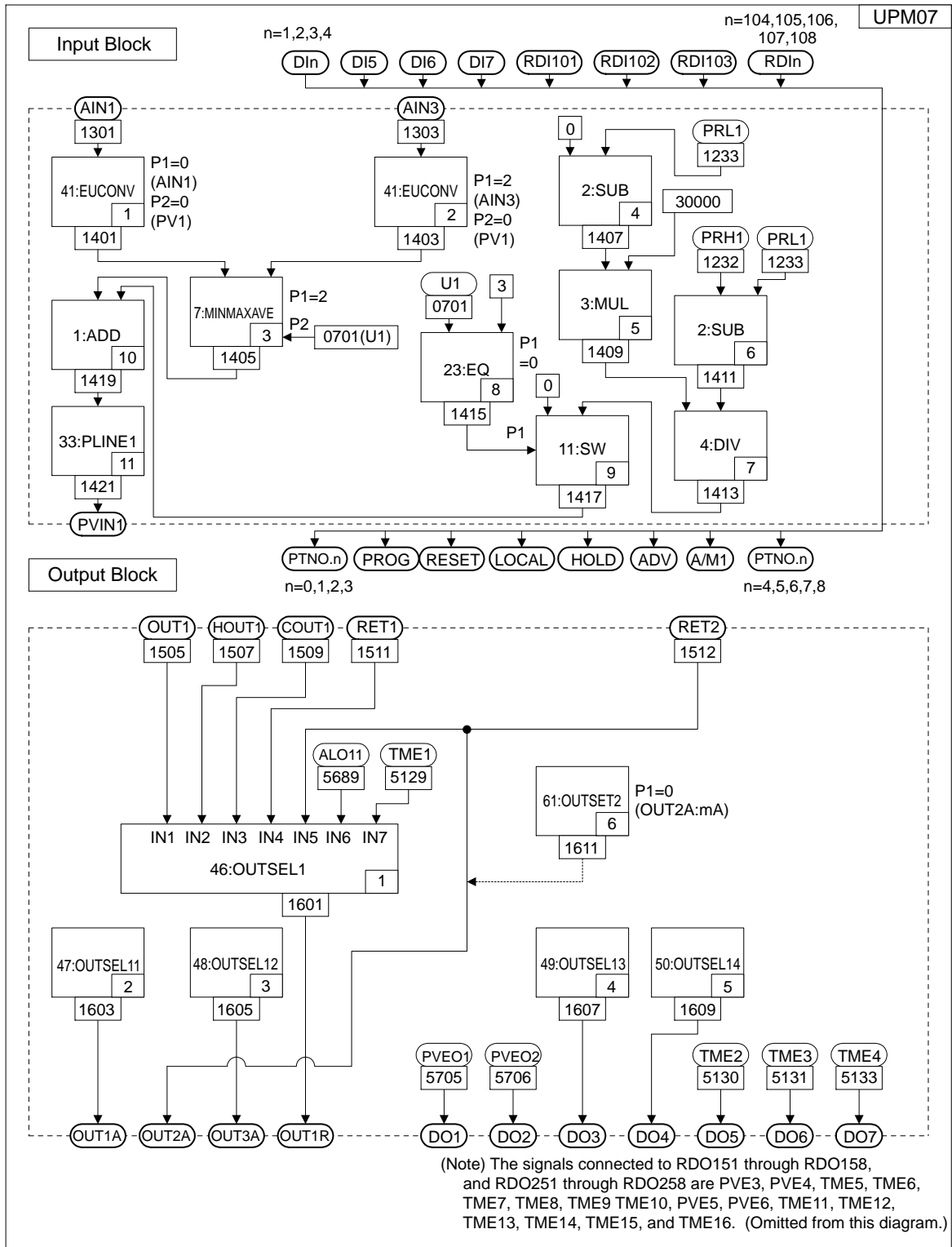

020501E.EPS

Figure 2.8 Input and Output Blocks for Loop Control with PV Auto-selector (UP Mode 7)

# 2.6 Input/Output Blocks for Dual-loop Control (UP Mode 11)

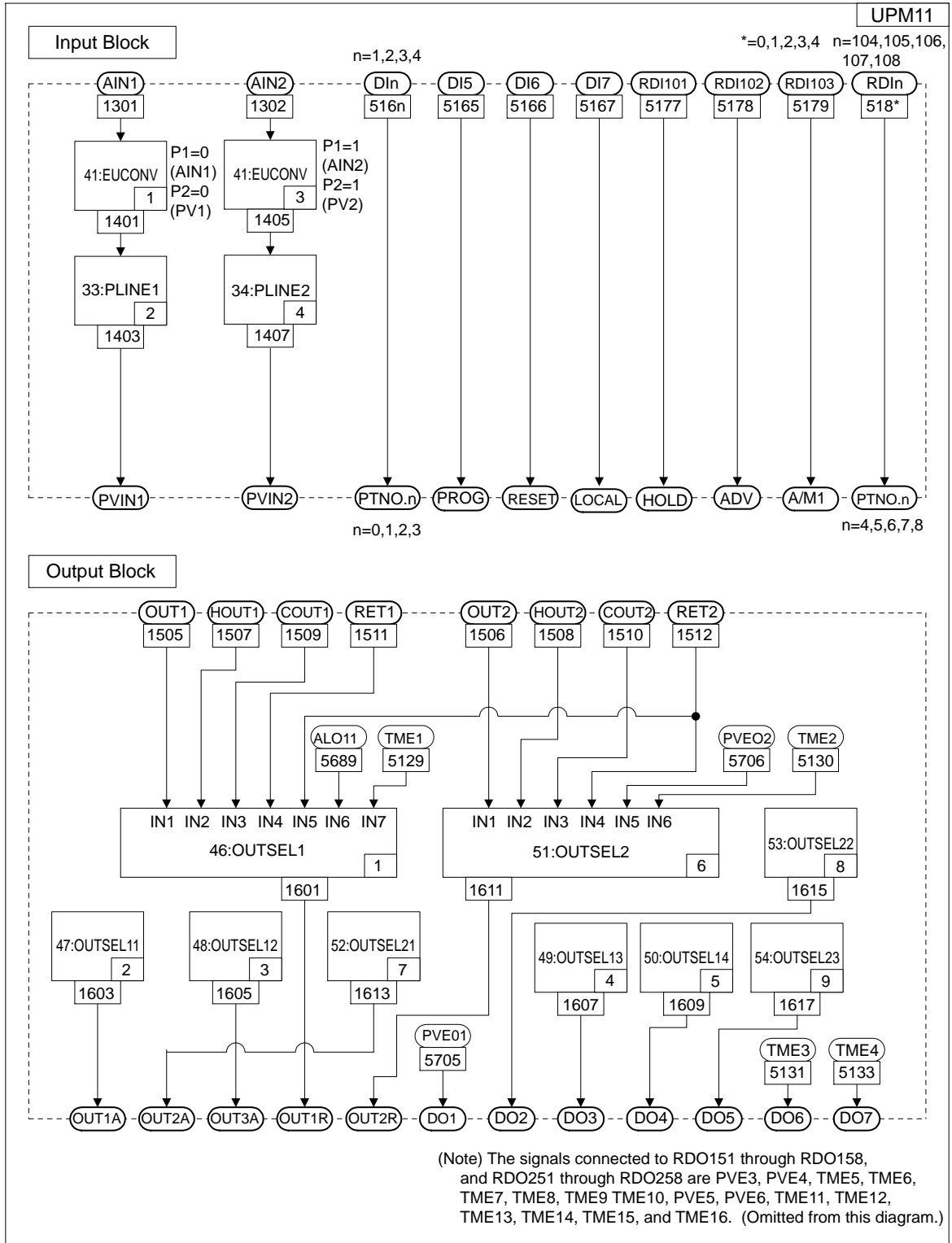

020601E.EPS

Figure 2.9 Input and Output Blocks for Dual-loop Control (UP Mode 11)



# 2.7 Input/Output Blocks for Temperature and Humidity Control (UP Mode 12)

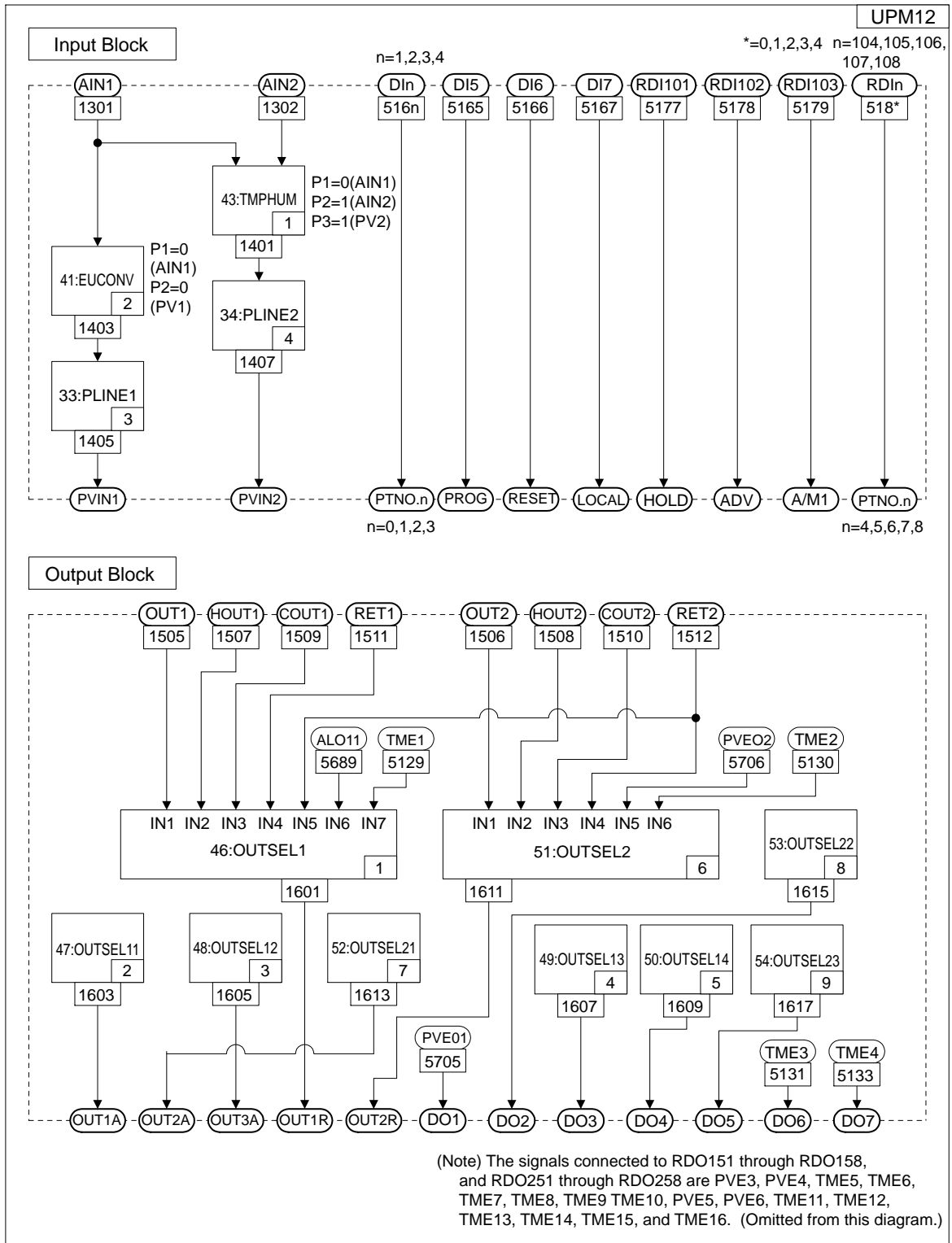
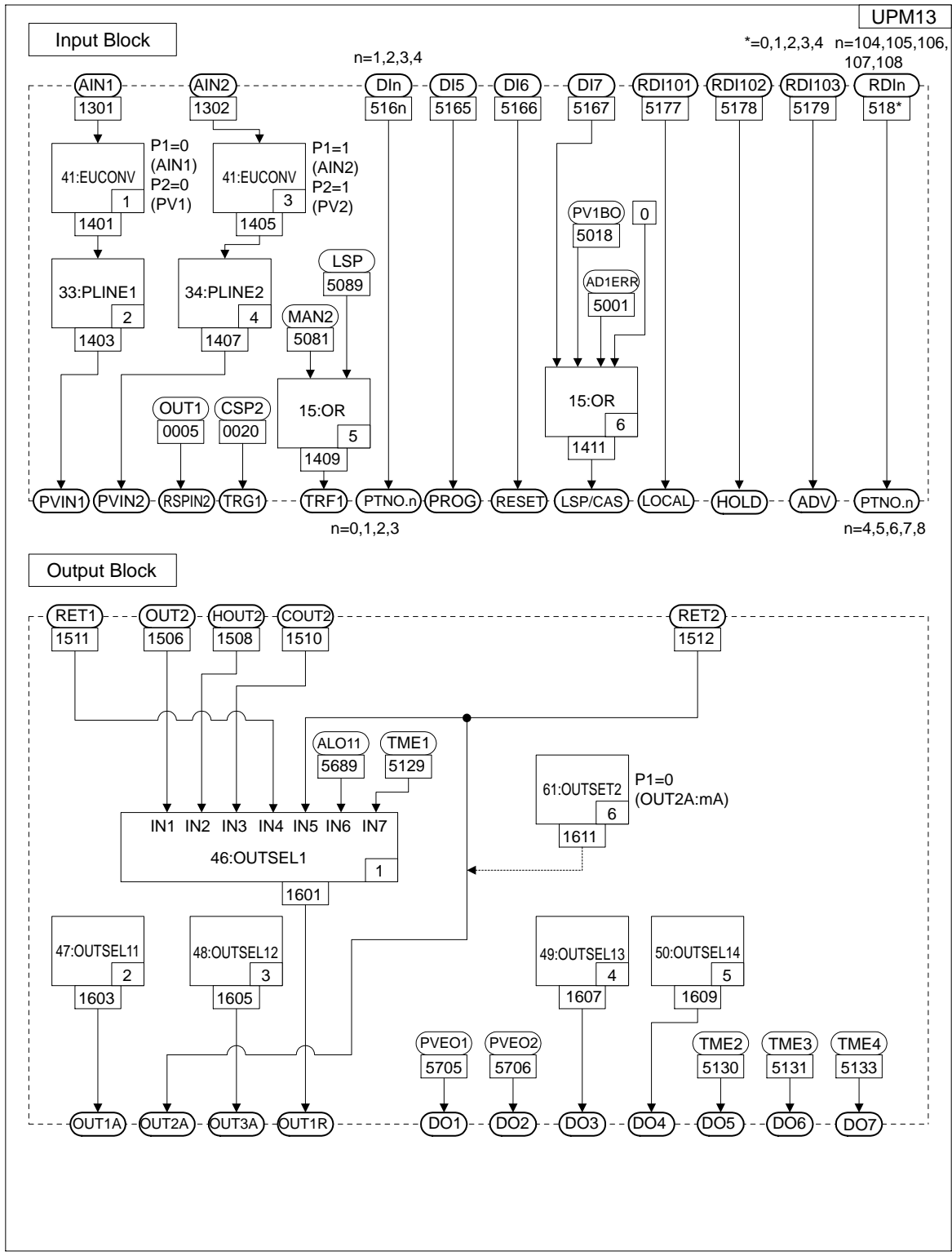

Figure 2.10 Input and Output Blocks for Temperature and Humidity Control (UP Mode 12)

# 2.8 Input/Output Blocks for Cascade Control with Two Universal Inputs (UP Mode 13)



020801E.EPS

Figure 2.11 Input and Output Blocks for Cascade Control with Two Universal Inputs (UP Mode 13)

# 2.9 Input/Output Blocks for Loop Control with PV Switching and Two Universal Inputs (UP Mode 14)

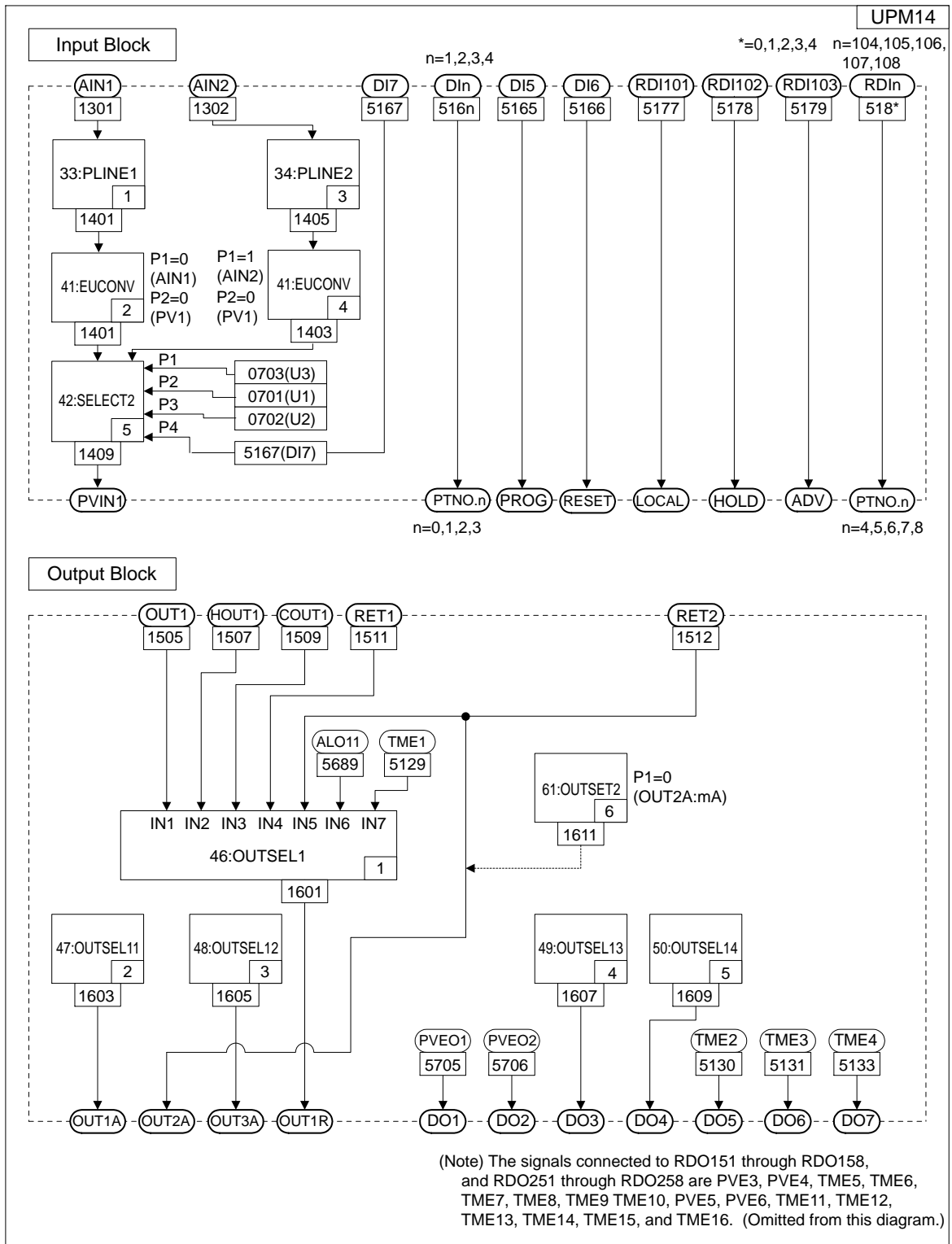

020901E.EPS

Figure 2.12 Input and Output Blocks for Loop Control with PV Switching and Two Universal Inputs (UP Mode 14)

# 2.10 Input/Output Blocks for Loop Control with PV Auto-selector and Two Universal Inputs (UP Mode 15)

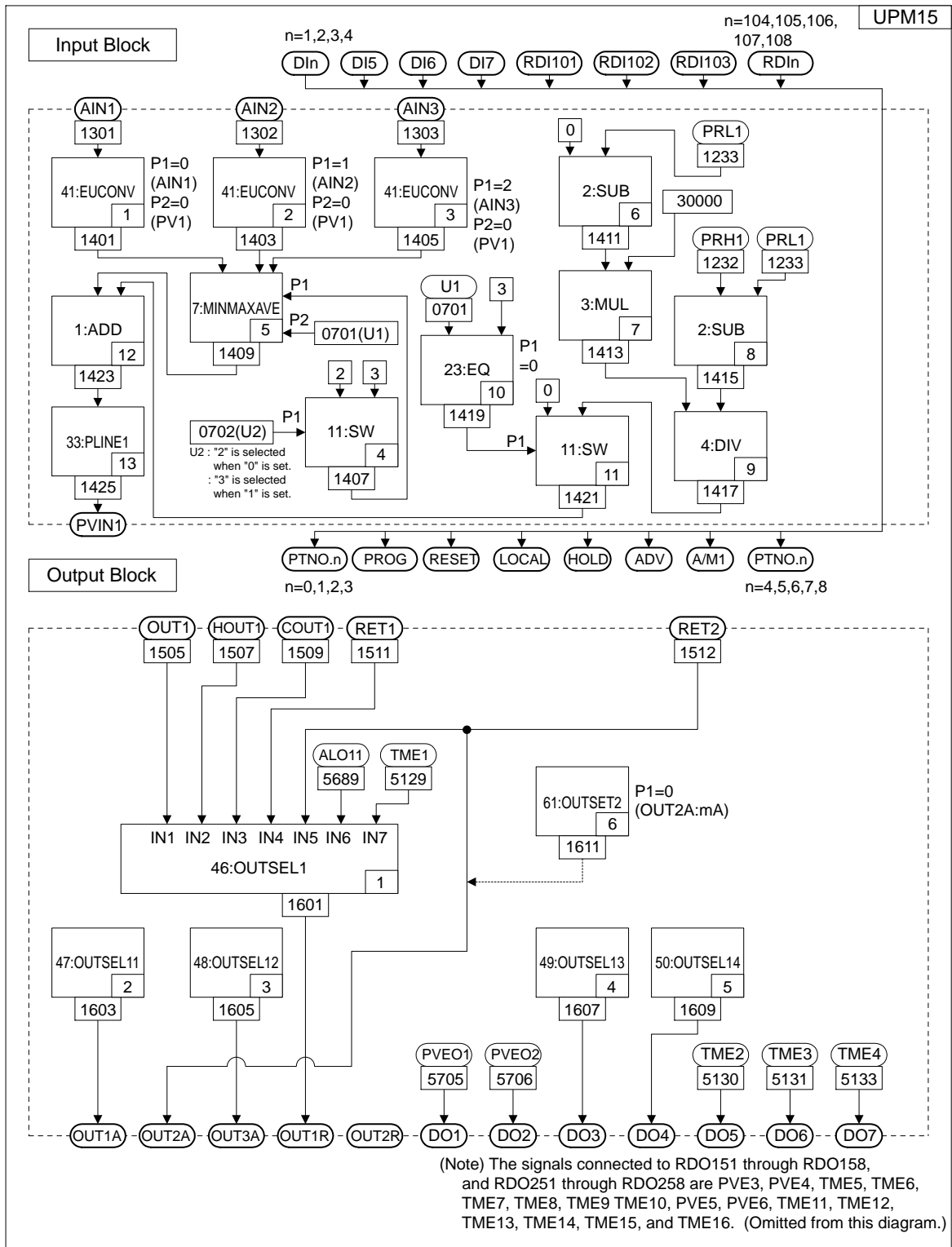

Figure 2.13 Input and Output Blocks for Loop Control with PV Auto-selector and Two Universal Inputs (UP Mode 15)

# 3. Types and Ranges of Computation Data

This chapter explains the types of computation data used in the input and output blocks, and their ranges. When you configure custom computations, you must make sure they comply with the specific types of computation data, such as range data, scale data and percentage-type data, which are fed to/from the input and output blocks. You can verify the computation data types in this chapter.

Figure 3.1 below shows an example of data flow where data taken in through analog input 1 (AIN1) is fed first to the EU Range Conversion (EUCONV) module and then the Ten-segment Linearizer 1 (PLINE1) module, for computation. The resulting data is then passed to the PVIN.1 signal of the loop 1 control-and-computing section.

If the AIN1 analog input is a thermocouple (TC) input or a resistance temperature detector (RTD) input, the input data has a value ranging from the minimum value of the analog input 1 range (RL) to the maximum value of the analog input 1 range (RH), which corresponds to the internal data range from 0 to 30000.

If AIN1 is a voltage input, the input data has a value ranging from the minimum value of the analog input 1 scale (SL) to the maximum value of the analog input 1 scale (SH), which corresponds to the internal data range from 0 to 30000.

The PVIN.1 signal has a value ranging from 0 to 30000, which is an internal value obtained by converting a value ranging from the minimum value of the PV1 range (P.RL1) to the maximum value of the PV1 range (P.RH1).

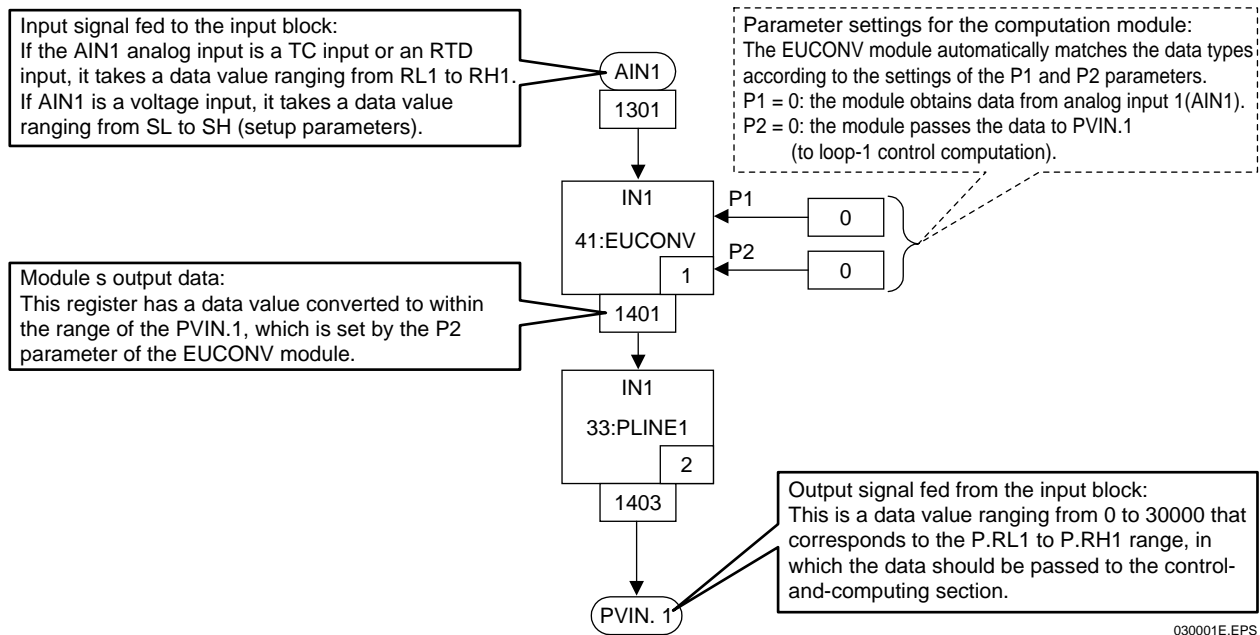

Figure 3.1 Data Flow

# 3.1 Types of Computation Data

The types of computation data used for custom computations are classified in the following table.

The table also summarizes the displayed values and the corresponding internal values, hereinafter referred to as computation data. See the next section for the data type of the I/O data of the input and output blocks.

Data Type	Actual Range of Data	Computation Data	Data Included	Remarks
Range	Minimum to maximum values of the range	-1500 to 31500 (*1)	Analog input, measured input, and others	The range is determined by RL and RH setup parameters.
Scale	Minimum to maximum values of the scale	-1500 to 31500 (*1)	Voltage input	The scale is determined by SL and SH setup parameters.
%	0.0 to 100.0%	-1500 to 31500 (*1)	Tracking input, control output, and others	The displayed data value of 0.0% to 100.0% corresponds to the computation data value of 0 to 30000
Gain	0.001 to 10.000	1 to 10000	Gain setting only	The displayed data value of 0.001 to 10.000 corresponds to the computation data value of 1 to 10000
Flag	0 or 1	0 or 1	Flags for control and others	0 represents OFF; 1 represents ON.
Integer	No specific range (Readout range is -19999 to 30000)	-30000 to 30000	Internal data without unit. All parameter settings belong to this type.	Out of -30000 to 30000 range, the portion of -19999 to 30000 can be shown on the controller. The RH value of 1500.0 corresponds to the computation data value of 15000.

\*1: This range corresponds to -5.0% to 105.0%.

Integer data is normally used to configure your own custom computations. It is signed 2-byte (16 bits) data, with a value limited to the ±30000 range. You can use data of up to 4-byte (32 bits) with a plus or minus sign, however, with some of the computation modules such as those for four arithmetic operations. For example, these modules can have the result of multiplying 2-byte data by 2-byte data as 4-byte data. In that case, the result is stored in two D registers (e.g., the MO1L register [lower-order word] and the MO1H register [higher-order word]).

### See Also

UP750 User's Manual for Single-loop Control (IM 05E01B02-01E to -07E) for setup parameters RL, RH, P.RL, P.RH, SL and SH.

## 3.2 Data Fed to the Input Block

The following table lists the data types and computation data used with the data items that are fed to the input block. When connecting computation modules to the input signals fed to the input block, check which data type and computation data apply.

Input Signal Code	D Register Number or I Relay Number	Specifications			
		Description	Data Type	Computation Data	Remarks
AIN1	1301	Analog input 1	Range	-1500 to 31500 (*1)	This data item uses the RH1 and RL1 range setting parameters. The computation data value of 0 is equivalent to RL1 and 30000 to RH1.
			Scale		This data item uses the SH1 and SL1 scale setting parameters. The computation data value of 0 is equivalent to SL1 and 30000 to SH1.
AIN2	1302	Analog input 2	Range		This data item uses the RH2 and RL2 range setting parameters. The computation data value of 0 is equivalent to RL2 and 30000 to RH2.
			Scale		This data item uses the SH2 and SL2 scale setting parameters. The computation data value of 0 is equivalent to SL2 and 30000 to SH2.
AIN3	1303	Analog input 3	Scale		This data item uses the SH3 and SL3 scale setting parameters. The computation data value of 0 is equivalent to SL3 and 30000 to SH3.
DI1	5161	Contact input 1	Flag		0 or 1
DI2	5162	Contact input 2			
DI3	5163	Contact input 3			
DI4	5164	Contact input 4			
DI5	5165	Contact input 5			
DI6	5166	Contact input 6			
DI7	5167	Contact input 7			
RDI101	5177	Expansion module 1 contact input 1			
RDI102	5178	Expansion module 1 contact input 2			
RDI103	5179	Expansion module 1 contact input 3			
RDI104	5180	Expansion module 1 contact input 4			
RDI105	5181	Expansion module 1 contact input 5			
RDI106	5182	Expansion module 1 contact input 6			
RDI107	5183	Expansion module 1 contact input 7			
RDI108	5184	Expansion module 1 contact input 8			
RDI201	5185	Expansion module 2 contact input 1			
RDI202	5186	Expansion module 2 contact input 2			
RDI203	5187	Expansion module 2 contact input 3			
RDI204	5188	Expansion module 2 contact input 4			
RDI205	5189	Expansion module 2 contact input 5			
RDI206	5190	Expansion module 2 contact input 6			
RDI207	5191	Expansion module 2 contact input 7			
RDI208	5192	Expansion module 2 contact input 8			

\*1: This computation data range of AIN1, AIN2, and AIN3 is equivalent to -5.0% to 105.0% of the ranges RL1 to RH1, SL1 to SH1, RL2 to RH2, SL2 to SH2, and SL3 to SH3. 030201E.EPS

### 3.3 Data Fed from the Input Block

The following table lists the data types and computation data used with the data items that are fed from the input block. When connecting computation modules to the output signals fed from the input block, check which data type and computation data apply.



**NOTE**

Depending on the input-block custom computation you configure, the resulting data may be out of the 0 to 30000 range. In order to match the data range to the range defined by the P.RL and P.RH parameters of the UP750, configure custom computations using the data ranges shown in the following table.

Output Signal Code	D Register Number	Specifications			
		Description	Data Type	Computation Data	Remarks
PVIN.1	1331	Loop 1 PV input	Range	-1500 to 31500 (*1)	This data item uses the P.RH1 and P.RL1 range setting parameters. The computation data value of 0 is equivalent to P.RL1 and 30000 to P.RH1.
PVIN.2	1332	Loop 2 PV input			This data item uses the P.RH2 and P.RL2 range setting parameters. The computation data value of 0 is equivalent to P.RL2 and 30000 to P.RH2.
PSPIN.1	1333	Loop 1 remote setpoint input		0 to 30000	This data item uses the P.RH1 and P.RL1 range setting parameters. The computation data value of 0 is equivalent to P.RL1 and 30000 to P.RH1.
PSPIN.2	1334	Loop 2 remote setpoint input			This data item uses the P.RH2 and P.RL2 range setting parameters. The computation data value of 0 is equivalent to P.RL2 and 30000 to P.RH2.
GAIN.1	1335	Loop 1 gain setting value	Gain (ABS)	0 to 10000	The controller carries outPID control using a proportional band divided by the gain. If the gain is 0, no gain-based action is taken. If the computation data is in the 1to10000 range, the actual data is in the range of 0.001 to 10.000 times the given proportional band.
GAIN.2	1336	Loop 2 gain setting value			

\*1: Corresponds to -5.0% to 105.0% of the ranges P.RL1 to P.RH1 and P.RL2 to P.RH2.



Continued from the previous table

Output Signal Code	D Register Number	Specifications			
		Description	Data Type	Computation Data	Remarks
TRG.1	1337	Loop 1 tracking input	%	-1500 to 31500 (*1)	<p>This input accepts the 0.0 to 100.0% range of an input signal as data in the 0 to 30000 range.</p> <p>When TRF.1 is on, the input block feeds the value of TRG.1 regardless of whether loop 1 is in AUTO mode or MAN mode.</p> <p>When TRF.1 changes from on to off, the controller resumes the AUTO mode or MAN mode operation using the TRG.1 value immediately before the status change.</p> <p>Manual output is possible when the loop is in the MAN mode.</p>
TRG.2	1338	Loop 2 tracking input			<p>This input accepts the 0.0 to 100.0% range of an input signal as data in the 0 to 30000 range.</p> <p>When TRF.2 is on, the input block feeds the value of TRG.2 regardless of whether loop 2 is in the AUTO mode or MAN mode.</p> <p>When TRF.2 changes from on to off, the controller resumes the AUTO mode or MAN mode operation using the TRG.2 value immediately before the status change.</p> <p>Manual output is possible when the loop is in the MAN mode.</p>
TRF.1	1339	Loop 1 tracking flag	Flag	0 or 1	1: Tracking is on. 0: Tracking is off.
TRF.2	1340	Loop 2 tracking flag			1: Tracking is on. 0: Tracking is off.

\*1: Corresponds to -5.0% to 105.0%.

Continued from the previous table

Output Signal Code	D Register Number	Specifications			
		Description	Data Type	Computation Data	Remarks
DP1	1378	Operating display selection 1	Flag	0 or 1	<p>A transition in this signal from 0 to 1 switches the operating display. The operating displays you can be view by interrupting the current display are as follows:</p> <ol style="list-style-type: none"> <li>1) SP (LSP) display</li> <li>2) OUT display</li> <li>3) Deviation trend display</li> <li>4) Event display</li> <li>5) Heating/cooling OUT display</li> <li>6) SP1 (LSP1) display</li> <li>7) Loop 1 Deviation trend display</li> <li>8) Pattern display</li> <li>9) LSP2 display</li> <li>10) Loop 2 Deviation trend display</li> <li>11) Pattern 1, 2 display</li> <li>12) Heating/cooling OUT2 display</li> <li>13) PV2/SP/OUT2 display</li> <li>14) PV2/SP/TM/RCY display</li> <li>15) PV2/OUT1 display</li> <li>16) PV2/OUT2 display</li> <li>17) Heating/cooling PV2/OUT1 display</li> <li>18) Heating/cooling PV2/OUT2 display</li> <li>19) DISP display</li> <li>20) Analog input display</li> <li>21) SP/PTN/SEG/TM/RCY display</li> <li>22) Heating/cooling PV2/SP/OUT2 display</li> <li>23) Unilluminated operating display</li> <li>24) SP1/TSP1 display</li> <li>25) SP1/TSP1/SP2/TSP2 display</li> </ol> <p><b>[See Also]</b> Section 6.1, "List of Operating Displays and Their Descriptions"</p> <p>Select the operating display to be switched to at the Operating Display Selection of the LL200. By turning on the contact registered with the DP1 or DP2 setup parameter, you can view the operating display registered with the display switching condition of "DP1 = on" or "DP2 = on," regardless of the current display.</p> <p><b>[See Also]</b> Section 6.3, "Display Switching Conditions for Operating Displays"</p>
DP2	1379	Operating display selection 2			
MG1	1380	Interruptive message display 1	Flag	0 or 1	<p>Displays messages on the LCD display. Edit the message text using the Parameters Setting Tool.</p> <p>If any of these signal flags turns on, the corresponding message appears on the UT750's LCD display (messages 1 to 4 will be shown in the first to the 4th lines on the display). You can clear the message shown by pressing the DISP key on the controller, and the controller returns to the normal display.</p> <p><b>[See Also]</b> User's manual of LL100 PC-based Parameters Setting Tool (IM 05G01B12-01E) for how to set messages.</p>
MG2	1381	Interruptive message display 2			
MG3	1382	Interruptive message display 3			
MG4	1383	Interruptive message display 4			

030303E.EPS

Continued from the previous table

Output Signal Code	D register No.	Specification			
		Description	Data Type	Computation Data	Remarks
PROG	1361	Program start	Flag	0 or 1	When data changes from 0 to 1 -> Program start (One shot switch)
RESET	1362	Reset			When data changes from 0 to 1 -> Reset (One shot switch)
LOCAL	1363	Local			When data changes from 0 to 1 -> Local (One shot switch)
HOLD	1364	Hold			When data changes from 0 to 1 -> Hold (One shot switch)
ADV	1365	Advance			When data changes from 0 to 1 -> Advance (One shot switch)
A/M.1	1366	Auto/Manual 1			1:AUTO, 0:MAN (toggle switch) When this is 1, the key operation is neglected.
A/M.2	1367	Auto/Manual 2			Same as above
LSP/CAS	1368	Local/Cascade			1:LOCAL, 0:CAS (toggle switch) When this is 1, the key operation is neglected.
PTNO.b0	1369	Program pattern setting bit 0			Set PT selection bit using binary data from DI.  0: Key setting is effective.  1 to 300: DI setting is effective.  301 or more: Key setting is effective.
PTNO.b1	1370	Same as above (bit1)			
PTNO.b2	1371	Same as above (bit2)			
PTNO.b3	1372	Same as above (bit3)			
PTNO.b4	1373	Same as above (bit4)			
PTNO.b5	1374	Same as above (bit5)			
PTNO.b6	1375	Same as above (bit6)			
PTNO.b7	1376	Same as above (bit7)			
PTNO.b8	1377	Same as above (bit8)			

030305E.EPS

### 3.4 Data Fed to the Output Block

The following table lists the data types and computation data used with the data items that are fed to the output block. When connecting computation modules to the input signals fed to the output block, check which data type and computation data apply.

Input Signal Code	D Register Number	Specifications			
		Description	Data Type	Computation Data	Remarks
PV.1	1501	Loop 1 PV	Range	-1500 to 31500 (*1)	This data item uses the P.RH1 and P.RL1 range setting parameters. The computation data value of 0 is equivalent to P.RL1 and 30000 to P.RH1.
PV.2	1502	Loop 2 PV			This data item uses the P.RH2 and P.RL2 range setting parameters. The computation data value of 0 is equivalent to P.RL2 and 30000 to P.RH2.
CSP.1	1503	Loop 1 SP		0 to 30000	This data item uses the P.RH1 and P.RL1 range setting parameters. The computation data value of 0 is equivalent to P.RL1 and 30000 to P.RH1.
CSP.2	1504	Loop 2 SP			This data item uses the P.RH2 and P.RL2 range setting parameters. The computation data value of 0 is equivalent to P.RL2 and 30000 to P.RH2.
OUT.1	1505	Loop 1 control output	%	-1500 to 31500 (*2)	The computation data value of 0 is equivalent to 0.0% and 30000 to 100.0%.
OUT.2	1506	Loop 2 control output			
HOUT.1	1507	Loop 1 heating-side control output			
HOUT.2	1508	Loop 2 heating-side control output			
COUT.1	1509	Loop 1 cooling-side control output			
COUT.2	1510	Loop 2 cooling-side control output			

\*1: Corresponds to -5.0% to 105.0% of the ranges P.RL1 to P.RH1 and P.RL2 to P.RH2.

030401E.EPS

\*2: Corresponds to -5.0% to 105.0%. Upon heating/cooling control, OUT1 and OUT2 range from -3150 to 31500.

Continued from the previous table

Input Signal Code	D Register Number	Specifications			
		Description	Data Type	Computation Data	Remarks
RET1	1511	Retransmission output 1	Range	-1500 to 31500 (*1)	This data item uses the RTH1 and RTL1 range setting parameters. The computation data value of 0 is equivalent to RTL1 and 30000 to RTH1.
			%		This data item changes to % type data if the RET1 setup parameter equals OUT1 or OUT2. The computation data value of 0 is equivalent to 0.0% and 30000 to 100.0%.
RET2	1512	Retransmission output 2	Range		This data item uses the RTH2 and RTL2 range setting parameters. The computation data value of 0 is equivalent to RTL2 and 30000 to RTH2.
			%		This data item changes to % type data if the RET2 setup parameter equals OUT1 or OUT2. The computation data value of 0 is equivalent to 0.0% and 30000 to 100.0%.

\*1: Corresponds to -5.0% to 105.0%

030402E.EPS

### 3.5 Data Fed from the Output Block

The following table lists the data types and computation data used with the data items that are fed from the output block. When connecting computation modules to the output signals fed from the output block, check which data type and computation data apply.

Output Signal Code	D Register Number	Specifications			
		Description	Data Type	Computation Data	Remarks
OUT1A	1531	Control output 1 (current/voltage pulse)	%		Voltage output or current pulse output
OUT2A	1532	Control output 2 (current/voltage pulse)			
OUT3A	1533	Analog output 3 (voltage)			
OUT1R	1534	Control output 1 (relay)	%	-1500 to 31500 (*1)	If this data item is time proportional output, the computation data value of 0 is equivalent to 0.0% and 30000 to 100.0%.  If this data item is on-off output, it works like flag data. The computation data value of 0 is equivalent to 0.0% (off) and 30000 to 100.0% (on).
			Flag		
OUT2R	1535	Control output 2 (relay)	%		
			Flag		
DO1	1536	Contact output 1 (relay)	Flag	0 or 1	The computation data value of 0 is equivalent to off and 1 to on.
DO2	1537	Contact output 2 (relay)			
DO3	1538	Contact output 3 (relay)			
DO4	1539	Contact output 4 (open collector)			
DO5	1540	Contact output 5 (open collector)			
DO6	1541	Contact output 6 (open collector)			
DO7	1542	Contact output 7 (open collector)			

\*1: Corresponds to -5.0% to 105.0%

Continued from the previous table

Input Signal Code	D Register Number or I Relay Number	Specifications			
		Description	Data Type	Computation Data	Remarks
RDO151	1543	Expansion module 1 contact output 1	Flag	0 or 1	The computation data value of 0 is equivalent to off, and 1 to on.
RDO152	1544	Expansion module 1 contact output 2			
RDO153	1545	Expansion module 1 contact output 3			
RDO154	1546	Expansion module 1 contact output 4			
RDO155	1547	Expansion module 1 contact output 5			
RDO156	1548	Expansion module 1 contact output 6			
RDO157	1549	Expansion module 1 contact output 7			
RDO158	1550	Expansion module 1 contact output 8			
RDO251	1551	Expansion module 2 contact output 1			
RDO252	1552	Expansion module 2 contact output 2			
RDO253	1553	Expansion module 2 contact output 3			
RDO254	1554	Expansion module 2 contact output 4			
RDO255	1555	Expansion module 2 contact output 5			
RDO256	1556	Expansion module 2 contact output 6			
RDO257	1557	Expansion module 2 contact output 7			
RDO258	1558	Expansion module 2 contact output 8			

030502E.EPS



**NOTE**

- To implement time-proportional output, you must use the Control Output Selection modules (module Nos. 46 to 54). However, it is recommended that you use the output blocks of the standard controller modes (UP modes) as they are.
- To implement current output, you must use the Output Terminal Configuration modules (module Nos. 60 and 61).

---

Blank Page



# 4. List of Computation Modules and Their Functions

This chapter explains the function specifications of each computation module. A list of the modules is presented first, and then the functions of each module are described.

The following paragraphs explain some of the specifications that appear throughout this chapter.

## ■ IN1 to IN8, P1 to P4, OUT

IN1 to IN8 represent the inputs of each computation module, P1 to P4 are the module parameters and OUT is the output. The following symbols are used to indicate the size of data that have functional assignments within each module.

- ⊙ : 4-byte data (two words)
- : 2-byte data (one word)
- : Flag data (0 or 1)



### NOTE

Some computation modules have their “OUT” marked with the symbol “×” which indicates that they themselves do not output any data. Output registers of such modules store the same data as that of their immediately preceding (in the execution order) module.

## ■ Work Area

Some computation modules require a “work area,” whose size is indicated with a number. You can use work areas up to a total size of 240. You cannot register computation modules that use work areas exceeding 240.

## ■ Limitation on Use

Computation modules with limited usage are given a number that indicates the number of times it can be used.

# 4.1 How to Hold Outputs at Power Failure and Recovery Using Custom Computation

## ■ Example: Holding the Output Value of SUM Module

Step 1) Save the output data value of a module into D1041 to D1050 (for word data) or D1051 to D1060 (for long word data) by using the No. 78 Data Save module.

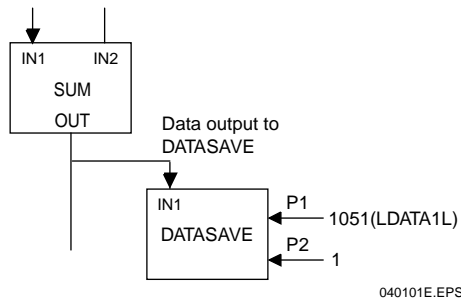

IN1 of DATASAVE: Input of DATASAVE. In this example, input the output of SUM.

P1 of DATASAVE: Specifies the register where the data is saved. Since SUM outputs long word data, specify D1051 (LDATA1L).

P2 of DATASAVE: Always set to "1" (write-enabled).

Step 2) At power on, use the saved data as the initial value.

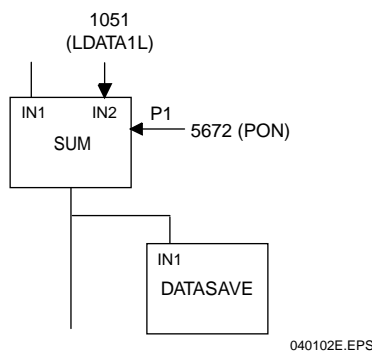

IN2 of SUM: Specify D1050 (LDATA1L) for an initial value of SUM.

P1 of SUM: Specify I0672 (PON: power-on flag, set 5672) as the initialization flag.



### NOTE

Since the Sum module (No. 30) cannot have an initial value when addition is specified, its output will be reset to 0. When subtraction is specified, an initial value lower than its output value will be 0.

# 4.2 List of Computation Modules

No.	Name	Code	Function	IN 1	IN 2	IN 3	IN 4	IN 5	IN 6	IN 7	IN 8	P1	P2	P3	P4	OUT	Work Area	Limitation on Use
1	Addition	ADD	OUT=IN1 + IN2	⊙	⊙											⊙		
2	Subtraction	SUB	OUT=IN1 - IN2	⊙	⊙											⊙		
3	Multiplication	MUL	OUT=IN1×IN2	⊙	⊙											⊙		
4	Division	DIV	OUT=IN1/IN2	⊙	⊙											⊙		
5	Absolute Value	ABS	OUT=ABS (IN1)	⊙												⊙		
6	Reciprocal	RECIPRO	OUT=P1/ (IN1 + P2)	⊙								⊙	⊙			⊙		
7	Auto Selector (Min./Max./Average/Difference)	MINMAXAVE	OUT = either the maximum, minimum, average or difference	○	○	○	○					○	○			○		
8	Hold Maximum Value	MAXHOLD	OUT = MAX (IN1, IN2, IN3, IN4, previous OUT)	○	○	○	○	○				○	●			○	2	
9	Hold Minimum Value	MINHOLD	OUT = MIN (IN1, IN2, IN3, IN4, previous OUT)	○	○	○	○	○				○	●			○	2	
10	Hold	HOLD	OUT = previously held IN1	○								●				○	2	
11	Switch	SWITCH	OUT = IN1 or IN2	⊙	⊙							●				⊙		
12	Limiter	LIMIT	OUT = IN1 limited to the range of P1 (upper limit) to P2 (lower limit)	⊙								⊙	⊙			⊙		
13	Constant	CONST	OUT = IN1	⊙												⊙		
14	AND Logic	AND	OUT = IN1∧IN2∧IN3∧IN4	●	●	●	●									●		
15	OR Logic	OR	OUT = IN1∨IN2∨IN3∨IN4	●	●	●	●									●		
16	XOR Logic	XOR	OUT = IN1∨IN2	●	●											●		
17	NOT Logic	NOT	OUT = $\overline{IN1}$	●												●		
18	Latch	LATCH	OUT = IN1 locked to on state	●								●				●	4	
19	Greater-than Logic	GT	OUT = 1 if IN1 ≥ IN2; OUT = 0 if IN1 < (IN2 - P1)	⊙	⊙							○				●	1	
20	Less-than Logic	LT	OUT = 1 if IN1 ≤ IN2; OUT = 0 if IN1 > (IN2 + P1)	⊙	⊙							○				●	1	
21	Decremental Counter	DCOUNTER	OUT = previous OUT - 1 when IN3 changes	●	●	●	○					●				○	3	
22	Counter	COUNTER	OUT = previous OUT + 1 when IN3 changes	●	●	●						●				○	3	
23	Equal-to Logic	EQ	OUT = 1 if IN1 = between IN2 and IN2 + P1	⊙	⊙							○				●		
24	Not-Equal-to Logic	NEQ	OUT = 1 if IN2 ≤ IN1 ≤ (IN2 + P1) is false	⊙	⊙							○				●		
25	Range Logic	RANGE	OUT = 1 if IN1 = between P1 and P2	⊙								⊙	⊙			●		
26	Delay Logic	DELAY	OUT = previous IN1 (output delay of one control period)	○												○	2	
27	AND (Long Word) Logic	ANDW	OUT = IN1∧IN2	⊙	⊙											⊙		
28	OR (Long Word) Logic	ORW	OUT = IN1∨IN2	⊙	⊙											⊙		
29	Word Shift	SHIFT	OUT = IN1 with a shift of P1	⊙								○	○			⊙		
30	Sum	SUM	OUT = previous OUT + IN1	⊙	⊙							●				⊙	4	
31	Timer	TIMER	OUT (flag) = 1 if timer count down reaches 0	●	●	●	○					●				●	4	
32	Rate-of-change Limiter	CHGLMT	OUT = IN1 whose rate of change is limited by P1 and P2	○								○	○	○	●	○	6	

⊙: Signed 4-byte data; ○: Signed 2-byte data; ●: Flag of 0 or 1; ×: No output

040201E.EPS

No.	Name	Code	Function	IN 1	IN 2	IN 3	IN 4	IN 5	IN 6	IN 7	IN 8	P1	P2	P3	P4	OUT	Work Area	Limitation on Use
33	10-segment Linearizer 1	PLINE1	OUT = IN1 determined by linear approximation based on the table of PYS1	○												○		
34	10-segment Linearizer 2	PLINE2	OUT = IN1 determined by linear approximation based on the table of PYS2	○												○		
35	Inverse 10-segment Linearizer 1	ILINE1	OUT = inverse of PLINE1 output	○												○		
36	Inverse 10-segment Linearizer 2	ILINE2	OUT = inverse of PLINE2 output	○												○		
37	Curve Linearizer 1	CURVE1	OUT = IN1 determined by curvilinear approximation based on the table of PYS1	○												○		
38	Curve Linearizer 2	CURVE2	OUT = IN1 determined by curvilinear approximation based on the table of PYS2	○												○		
39	Ratio	RATIO	OUT = (IN1×P1/P2) + P3	○								○	○	⊙		⊙		
40	First Order Lag Filter	FILTER	Previous OUT + (IN1-previous OUT) / (1 + P1 / control period)	○								○	●			○	4	
41	EU Range Conversion	EUCONV	OUT = IN1 with unit converted from P1's to P2's unit	○								○	○			○		
42	Switching Between 2 Inputs	SELECT2	OUT = computation obtained according to the type of switching applied for IN1 and IN2	○	○							○	○	○	●	○	2	
43	Temperature and Humidity Calculation	TMPHUM	OUT = relative humidity determined from the readings of dry- and wet-bulb temperatures	○	○							○	○	○		○		1
44	Square Root Extraction	SQR	OUT = √(IN1), where low signal cutoff based on P1 is applied	○								○				○		
45	Detection of Change	CHGDET	OUT = 1 for one control period if IN1 changes	●												●	1	
46	Loop 1 Output Selection 1	OUTSEL1	OUT = output for OUT1R (control output: relay output)	○	○	○	○	○	○	○						○		1
47	Loop 1 Output Selection 11	OUTSEL11	OUT = output for OUT1A (control output or RET2 output)													○		1
48	Loop 1 Output Selection 12	OUTSEL12	OUT = output for OUT3A (control output on cooling side or RET1 output)													○		1
49	Loop 1 Output Selection 13	OUTSEL13	OUT = output for D03 (relay control output on cooling side or AL 3)													○		1
50	Loop 1 Output Selection 14	OUTSEL14	OUT = output for DO4 (transistor control output on cooling side or AL4)													○		1
51	Loop 2 Output Selection 2	OUTSEL2	OUT = output for OUT2R (control output: relay output)	○	○	○	○	○								○		1

⊙: Signed 4-byte data; ○: Signed 2-byte data; ●: Flag of 0 or 1; ×: No output

040202E.EPS

No.	Name	Code	Function	IN 1	IN 2	IN 3	IN 4	IN 5	IN 6	IN 7	IN 8	P1	P2	P3	P4	OUT	Work Area	Limitation on Use
52	Loop 2 Output Selection 21	OUTSEL21	OUT = output for OUT2A (control output or RET2 output or RET2 output)													○		1
53	Loop 2 Output Selection 22	OUTSEL22	OUT = output for DO2 (relay control output on cooling side or 1.AL2)													○		1
54	Loop 2 Output Selection 23	OUTSEL23	OUT = output for DO5 (transistor control output on cooling side or 2.AL1)													○		1
55	Display Data Unit Conversion	DISPCHG	OUT = absolute value without decimal point obtained by converting IN1 reading	○								○				○		
56	Parameter Setting	PARASET	Writes IN1 into register specified in P1, when P2 changes from 0 to 1	○								○	●			×	4	
57	Data Display 1	DISP1	Shows IN1 on the DISP1 customized display	○								○				×		1
58	Data Display 2	DISP2	Shows IN1 on the DISP2 customized display	○								○				×		1
59	Special DO Output	EXRDO	Outputs IN1 value as a 16-bit pattern to the expanded contact outputs.	○								○				×		1
60	Output 1 Terminal Configuration	OUTSET1	Selects the function of OUT1A terminal: mA output if P1 = 0, voltage pulse output if P1 = 1									●				×		1
61	Output 2 Terminal Configuration	OUTSET2	Selects the function of OUT2A terminal: mA output if P1 = 0, voltage pulse output if P1 = 1									●				×		1
62	Fluid Temperature Compensation	TCOMP	$OUT = IN1 \times (IN2 + P2) / (P1 + P2)$	○	○							○	○	○		○		
63	Fluid Pressure Compensation	PCOMP	$OUT = IN1 \times (IN2 + P2) / (P1 + P2)$	○	○							○	○	○		○		
64	10-segment Linearizer 3	PLINE3	OUT = IN1 determined by linear approximation based on table of PYS3 parameters	○												○		
65	10-segment Linearizer 4	PLINE4	OUT = IN1 determined by linear approximation based on table of PYS4 parameters	○												○		
66	None	-	-	-	-	-	-	-	-	-	-	-	-	-	-	-	-	-
67	Dead Time	DED	OUT = the value of IN1 given prior to the P1 time	○								○	●			○	46	
68	Moving Average	MAV	OUT = the average of IN1 given prior to the P1 time	○								○	●			○	46	
69	Multi-selector	MSELECT	OUT = a value selected from IN1 to IN8	○	○	○	○	○	○	○	○	○	○	○		◎		
70	Edge-triggered Counter	ECOUNTER	OUT = previous value of OUT + P4 when IN3 changes	●	●	●	○					○	○	○	○	○	3	
71	Edge-triggered Timer	ETIMER	OUT (flag) = 1 if the timer counts down to 0.	●	●	●	○					●	○			●	4	

◎: Signed 4-byte data; ○: Signed 2-byte data; ●: Flag of 0 or 1; ×: No output

040203E.EPS

No.	Name	Code	Function	IN 1	IN 2	IN 3	IN 4	IN 5	IN 6	IN 7	IN 8	P1	P2	P3	P4	OUT	Work Area	Limitation on Use
72	Detection of Change at Edge	ECHGDET	OUT = 1 for one control period if IN1 changes (at the rising or falling edge)	●								●				●	1	
73	Square Root Extraction 2	SQR2	OUT = $\sqrt{IN1}$ , where P1 is low signal cut-off point	○								○				○	7	
74	Flow Sum	FLWSUM	Integrates IN3 and outputs the result	●	●	○	○					○	●	○		○		
75	Integrated Pulse Output	CPO	Integrates IN and outputs pulses by the number according to the integration factor.	●	●	○						○	○			●	7	
76	BCD Conversion	BCD	Converts a BCD code into a decimal number.	●	●	●	●	●	●	●	●					○		
77	XOR (Long Word) Logic	XORW	OUT = IN1 $\forall$ IN2	◎	◎											◎		
78	Data Save	DATASAVE	When P2 = 1, writes IN1 value into the register specified with P1.	◎								○	●			×		

◎: Signed 4-byte data; ○: Signed 2-byte data; ●: Flag of 0 or 1; ×: No output

040204E.EPS

# 4.3 Explanation of Computation Modules

Module No.	<b>1</b>		Category	Arithmetic Operation
Module Name	Addition		Module Code Name	<b>ADD</b>
Module Input			<b>[Computational Expression]</b> $OUT = IN1 + IN2$	
IN1	⊙	Augend		
IN2	⊙	Addend		
IN3				
IN4				
IN5				
IN6				
IN7				
IN8				
Module Parameter			<b>[Explanation]</b> The module outputs the value obtained by adding IN2 to IN1. If an overflow occurs, it outputs: <ul style="list-style-type: none"> <li>• the maximum value when the addition is "(positive value) + (positive value)," or</li> <li>• the minimum value when the addition is "(negative value) + (negative value)."</li> </ul>	
P1				
P2				
P3				
P4				
Module Output				
OUT	⊙	Sum		
Work Area				
Limitation on Usage				
⊙: Signed 4-byte data; ○: Signed 2-byte data; ●: Flag of 0 or 1; ×: No output				

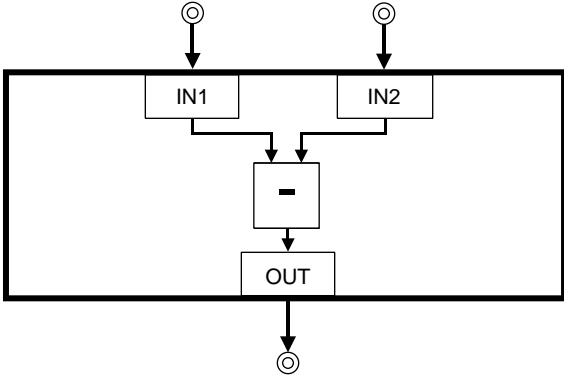
Module No.	<b>2</b>		Category	Arithmetic Operation
Module Name	Subtraction		Module Code Name	<b>SUB</b>
Module Input			<p><b>[Computational Expression]</b>  <math>OUT = IN1 - IN2</math></p> 	
IN1	⊙	Minuend		
IN2	⊙	Subtrahend		
IN3				
IN4				
IN5				
IN6				
IN7				
IN8				
Module Parameter				
P1				
P2				
P3				
P4				
Module Output				
OUT	⊙	Remainder		
Work Area				
Limitation on Usage				
⊙: Signed 4-byte data; ○: Signed 2-byte data; ●: Flag of 0 or 1; ×: No output				

040302E.EPS

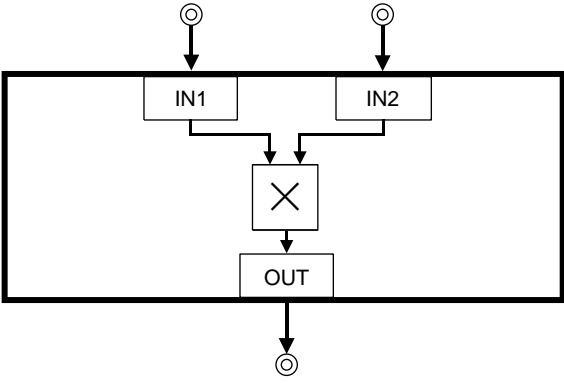
Module No.	<b>3</b>		Category	Arithmetic Operation
Module Name	Multiplication		Module Code Name	<b>MUL</b>
Module Input			<p><b>[Computational Expression]</b>  <math>OUT = IN1 \times IN2</math></p> 	
IN1	⊙	Multiplicand		
IN2	⊙	Multiplier		
IN3				
IN4				
IN5				
IN6				
IN7				
IN8				
Module Parameter				
P1				
P2				
P3				
P4				
Module Output				
OUT	⊙	Product		
Work Area				
Limitation on Usage				
⊙: Signed 4-byte data; ○: Signed 2-byte data; ●: Flag of 0 or 1; ×: No output				

040303E.EPS

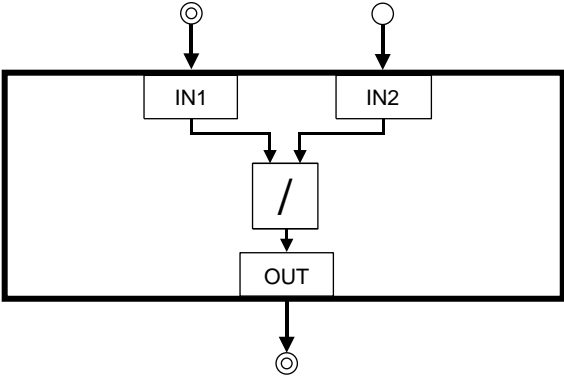

Module No.	<b>4</b>		Category	Arithmetic Operation
Module Name	Division		Module Code Name	<b>DIV</b>
Module Input			<p><b>[Computational Expression]</b>  <math>OUT = IN1/IN2</math></p>  <pre> graph TD     IN1((IN1)) --&gt; Div(/)     IN2((IN2)) --&gt; Div     Div --&gt; OUT((OUT))             </pre>	
IN1	⊙	Dividend		
IN2	○	Divisor		
IN3				
IN4				
IN5				
IN6				
IN7				
IN8				
Module Parameter				
P1				
P2				
P3				
P4				
Module Output				
OUT	⊙	Quotient		
Work Area				
Limitation on Usage				
⊙: Signed 4-byte data; ○: Signed 2-byte data; ●: Flag of 0 or 1; ×: No output				

040304E.EPS

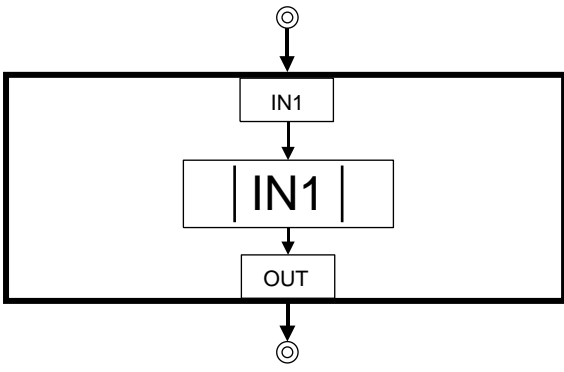
Module No.	<b>5</b>		Category	Arithmetic Operation
Module Name	Absolute Value		Module Code Name	<b>ABS</b>
Module Input			<p><b>[Computational Expression]</b>  <math>OUT = ABS (IN1)</math></p>  <pre> graph TD     IN1((IN1)) --&gt; Abs( IN1 )     Abs --&gt; OUT((OUT))             </pre>	
IN1	⊙	Input 1		
IN2				
IN3				
IN4				
IN5				
IN6				
IN7				
IN8				
Module Parameter				
P1				
P2				
P3				
P4				
Module Output				
OUT	⊙	Absolute value		
Work Area				
Limitation on Usage				
⊙: Signed 4-byte data; ○: Signed 2-byte data; ●: Flag of 0 or 1; ×: No output				

040305E.EPS

Module No.	<b>6</b>		Category	Arithmetic Operation
Module Name	Reciprocal		Module Code Name	<b>RECIPRO</b>
Module Input			<p><b>[Computational Expression]</b>  <math>OUT = P1/(IN1 + P2)</math></p>	
IN1	⊙	Input 1		
IN2				
IN3				
IN4				
IN5				
IN6				
IN7				
IN8				
Module Parameter				
P1	⊙	Coefficient 1		
P2	⊙	Coefficient 2		
P3				
P4				
Module Output			<p><b>[Explanation]</b>                  The module outputs the reciprocal of IN1.</p> <p>If the result of computation is 0, the module outputs:</p> <ul style="list-style-type: none"> <li>• 1 when the signs of the dividend and divisor are the same, or</li> <li>• -1 when the signs of the dividend and divisor differ.</li> </ul> <p>Additions and divisions included in the computational expression comply with the specifications of the addition and division modules.</p>	
OUT	⊙	Reciprocal		
Work Area				
Limitation on Usage				
<p>⊙: Signed 4-byte data; ○: Signed 2-byte data; ●: Flag of 0 or 1; ×: No output</p>				

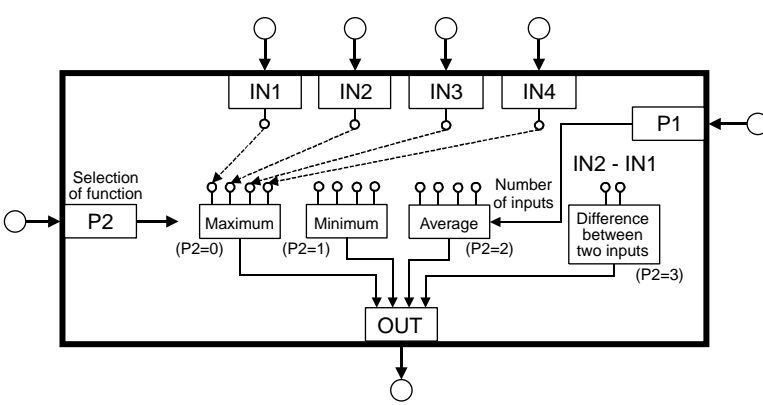
Module No.	<b>7</b>		Category	Arithmetic Operation
Module Name	Auto Selector (Min./Max./Average/Difference)		Module Code Name	<b>MINMAXAVE</b>
Module Input			<p><b>[Computational Expression]</b>                  P2 = 0: outputs the maximum; <math>OUT = MAX (IN1, IN2, IN3, IN4)</math>                  P2 = 1: outputs the minimum; <math>OUT = MIN (IN1, IN2, IN3, IN4)</math>                  P2 = 2: outputs the average                  If P1 = 1, then <math>OUT = IN1</math>                  If P1 = 2, then <math>OUT = (IN1 + IN2)/2</math>                  If P1 = 3, then <math>OUT = (IN1 + IN2 + IN3)/3</math>                  If P1 = 4, then <math>OUT = (IN1 + IN2 + IN3 + IN4)/4</math>                  P2 = 3: outputs the remainder; <math>OUT = (IN2 - IN1)</math></p> 	
IN1	<input type="radio"/>	Input 1		
IN2	<input type="radio"/>	Input 2		
IN3	<input type="radio"/>	Input 3		
IN4	<input type="radio"/>	Input 4		
IN5				
IN6				
IN7				
IN8				
Module Parameter				
P1	<input type="radio"/>	Number of inputs (1 to 4)		
P2	<input type="radio"/>	Selection of function (0 to 3)		
P3				
P4				
Module Output				
OUT	<input type="radio"/>	Automatically selected output		
Work Area				
Limitation on Usage				
			<p><b>[Explanation]</b>                  The module outputs the maximum or minimum input from among up to four inputs (IN1 to IN4), or the difference between two inputs.</p> <p>If P1 = 1, the module always outputs IN1.                  If P1 ≠ 1 to 4, the module always outputs 0.                  If P2 ≠ 0 to 3, the module operates assuming P2 = 0.</p> <p><b>[TIP]</b>                  P1: Specify the number of inputs (1 to 4). (The number of inputs specified by P1, and beginning with IN1, are included in the computation.)                  P2: Selection of function (P2 = 0: outputs the maximum; P2 = 1: outputs the minimum; P2 = 2: outputs the average; P2 = 3: outputs the remainder)</p>	
			<p>⊙: Signed 4-byte data; ○: Signed 2-byte data; ●: Flag of 0 or 1; ×: No output</p>	

Module No.	<b>8</b>		Category	Arithmetic Operation
Module Name	Hold Maximum Value		Module Code Name	<b>MAXHOLD</b>
Module Input			<p><b>[Computational Expression]</b>  <math>OUT = \text{MAX} (IN1, IN2, IN3, IN4, \text{previous OUT})</math></p>	
IN1	<input type="radio"/>	Input 1		
IN2	<input type="radio"/>	Input 2		
IN3	<input type="radio"/>	Input 3		
IN4	<input type="radio"/>	Input 4		
IN5	<input type="radio"/>	Initial value		
IN6				
IN7				
IN8				
Module Parameter				
P1	<input type="radio"/>	Number of inputs (1 to 4)		
P2	<input checked="" type="radio"/>	Initialization flag		
P3				
P4				
Module Output				
OUT	<input type="radio"/>	Maximum value output		
Work Area	2			
Limitation on Usage				
			<p><b>[Explanation]</b>                      The module outputs whichever is greater, the maximum among IN1 to IN4 or the previous OUT.</p> <p>If P1 ≠ 1 to 4, the module outputs 0.                      If P2 = 1, the module outputs the initial value (IN5).</p> <p><b>[TIP]</b>                      P1: Specify the number of inputs (1 to 4). (The number of inputs specified by P1, and beginning with IN1, are included in the computation.)                      P2: Initialization flag (initializes the output if P2 = 1)</p> <p><b>[NOTE]</b>                      The value of OUT is reset to 8001h (= the minimum value of signed 2-byte data) upon power failure.                      (The maximum input value at power recovery will be the first output.)</p>	

⊙: Signed 4-byte data; ○: Signed 2-byte data; ●: Flag of 0 or 1; ×: No output

Module No.	<b>9</b>		Category	Arithmetic Operation
Module Name	Hold Minimum Value		Module Code Name	<b>MINHOLD</b>
Module Input			<p><b>[Computational Expression]</b>  <math>OUT = \text{MIN}(IN1, IN2, IN3, IN4, \text{previous OUT})</math></p>	
IN1	<input type="radio"/>	Input 1		
IN2	<input type="radio"/>	Input 2		
IN3	<input type="radio"/>	Input 3		
IN4	<input type="radio"/>	Input 4		
IN5	<input type="radio"/>	Initial value		
IN6				
IN7				
IN8				
Module Parameter			<p><b>[Explanation]</b>                  The module outputs whichever is smaller, the minimum among IN1 to IN4 or the previous OUT.</p> <p>If P1 ≠ 1 to 4, the module outputs 0.                  If P2 = 1, the module outputs the initial value (IN5).</p> <p><b>[TIP]</b>                  P1: Specify the number of inputs (1 to 4). (The number of inputs specified by P1, and beginning with IN1, are included in the computation.)                  P2: Initialization flag (initializes the output if P2 = 1)</p> <p><b>[NOTE]</b>                  The value of OUT is reset to 7FFFh (= the maximum value of signed 2-byte data) upon power failure.                  (The minimum input value at power recovery will be the first output.)</p>	
P1	<input type="radio"/>	Number of inputs (1 to 4)		
P2	<input checked="" type="radio"/>	Initialization flag		
P3				
P4				
Module Output				
OUT	<input type="radio"/>	Maximum value output		
Work Area			2	
Limitation on Usage				
			<p>⊙: Signed 4-byte data; ○: Signed 2-byte data; ●: Flag of 0 or 1; ×: No output</p>	

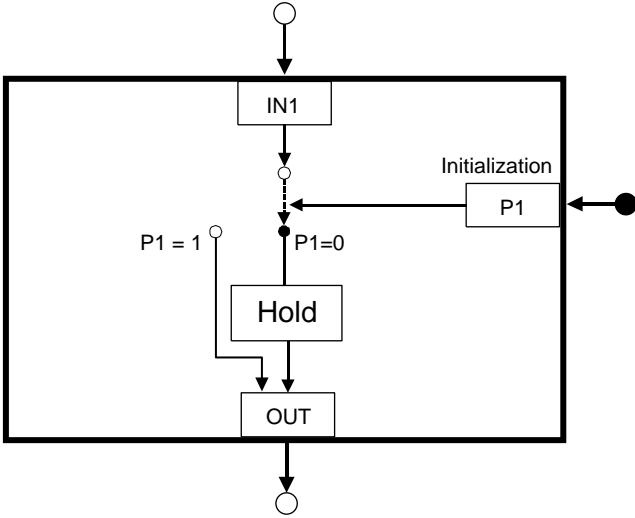
Module No.	<b>10</b>		Category	Arithmetic Operation
Module Name	Hold		Module Code Name	<b>HOLD</b>
Module Input			<p><b>[Computational Expression]</b>                  OUT = held at previous IN1 (IN1 one control period earlier)</p> 	
IN1	<input type="radio"/>	Input 1		
IN2				
IN3				
IN4				
IN5				
IN6				
IN7				
IN8				
Module Parameter				
P1	<input checked="" type="radio"/>	Initialization flag		
P2				
P3				
P4				
Module Output				
OUT	<input type="radio"/>	Held value output		
Work Area	2			
Limitation on Usage				
			<p><b>[Explanation]</b>                  The module retains IN1 until P1 takes a value other than 0.</p> <p><b>[TIP]</b>                  P1: Initialization flag                  If P1 = 0, the module retains and outputs the value of IN1 obtained when P1 = 1.                  If P1 = 1, the module outputs the value of IN1 as is.</p> <p><b>[NOTE]</b>                  The value of OUT is reset to 0 upon power failure.</p>	
<p>⊙: Signed 4-byte data; ○: Signed 2-byte data; ●: Flag of 0 or 1; ×: No output</p>				

040310E.EPS

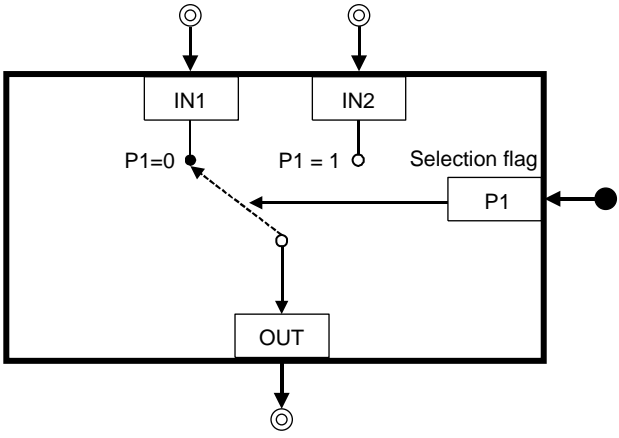
Module No.	<b>11</b>		Category	Arithmetic Operation
Module Name	Switch		Module Code Name	<b>SWITCH</b>
Module Input			<p><b>[Computational Expression]</b>                  OUT = IN1 or IN2</p> 	
IN1	<input checked="" type="radio"/>	Input 1		
IN2	<input checked="" type="radio"/>	Input 2		
IN3				
IN4				
IN5				
IN6				
IN7				
IN8				
Module Parameter				
P1	<input checked="" type="radio"/>	Selection flag		
P2				
P3				
P4				
Module Output				
OUT	<input checked="" type="radio"/>	Selected value		
Work Area				
Limitation on Usage				
			<p><b>[Explanation]</b>                  The module outputs IN1 if P1 = 0, or IN2 if P1 = 1.</p> <p><b>[TIP]</b>                  P1: Selection flag                  If P1 = 0, the module outputs the value of IN1.                  If P1 = 1, the module outputs the value of IN2.</p>	
<p>⊙: Signed 4-byte data; ○: Signed 2-byte data; ●: Flag of 0 or 1; ×: No output</p>				

040311E.EPS

Module No.		<b>12</b>		Category		Arithmetic Operation	
Module Name		Limiter		Module Code Name		<b>LIMIT</b>	
Module Input				<p><b>[Computational Expression]</b>  <math>OUT = P2 \leq IN1 \leq P1</math></p>			
IN1	⊙	Input 1					
IN2							
IN3							
IN4							
IN5							
IN6							
IN7							
IN8							
Module Parameter				<p><b>[Explanation]</b>                  The module outputs the value of IN1 while limiting it to within the range of P1 (setting value of upper limit) to P2 (setting value of lower limit).</p>			
P1	⊙	Setting value of upper limit					
P2	⊙	Setting value of lower limit					
P3							
P4							
Module Output				<p>If the upper limit becomes smaller than the lower limit (<math>P1 \leq P2</math>), the module outputs P1 when IN1 is greater than P1, or P2 when IN1 is smaller than P1.</p>			
OUT	⊙	Output with limiter					
Work Area							
Limitation on Usage							

⊙ : Signed 4-byte data; ○ : Signed 2-byte data; ● : Flag of 0 or 1; × : No output

Module No.	<b>13</b>		Category	Arithmetic Operation
Module Name	Constant		Module Code Name	<b>CONST</b>
Module Input			<p><b>[Computational Expression]</b>                  OUT = IN1</p>	
IN1	⊙	Input1		
IN2				
IN3				
IN4				
IN5				
IN6				
IN7				
IN8				
Module Parameter			<p><b>[Explanation]</b>                  The module outputs the value of IN1 as is.</p>	
P1				
P2				
P3				
P4				
Module Output				
OUT	⊙	Constant		
Work Area				
Limitation on Usage				
<p>⊙: Signed 4-byte data; ○: Signed 2-byte data; ●: Flag of 0 or 1; ×: No output</p>				

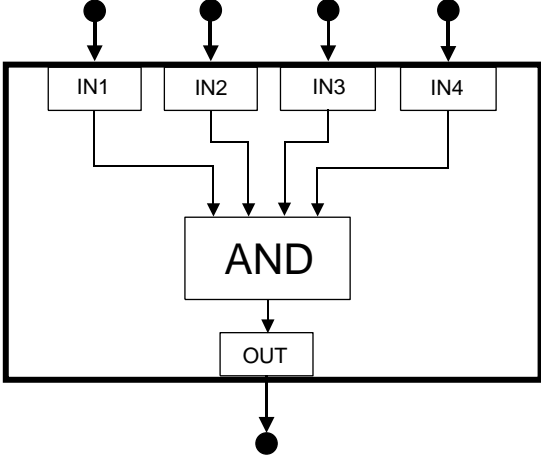

Module No.	<b>14</b>		Category	Logical Operation																																								
Module Name	AND Logic		Module Code Name	<b>AND</b>																																								
Module Input			<p><b>[Computational Expression]</b>  <math>OUT = IN1 \wedge IN2 \wedge IN3 \wedge IN4</math></p> 																																									
IN1	●	Input 1																																										
IN2	●	Input 2																																										
IN3	●	Input 3																																										
IN4	●	Input 4																																										
IN5																																												
IN6																																												
IN7																																												
IN8																																												
Module Parameter																																												
P1																																												
P2																																												
P3																																												
P4																																												
Module Output																																												
OUT	●	AND logic result	<p><b>[Explanation]</b>                      The module outputs the AND logic for IN1 to IN4.                      Example: <math>1 = 1 \wedge 1 \wedge 1 \wedge 1</math>, <math>0 = 1 \wedge 0 \wedge 1 \wedge 1</math></p> <table border="1" data-bbox="754 891 1051 1155"> <thead> <tr> <th>IN1</th> <th>IN2</th> <th>IN3</th> <th>IN4</th> <th>OUT</th> </tr> </thead> <tbody> <tr> <td>0</td> <td>0</td> <td>0</td> <td>0</td> <td>0</td> </tr> <tr> <td>1</td> <td>0</td> <td>0</td> <td>0</td> <td>0</td> </tr> <tr> <td>0</td> <td>1</td> <td>0</td> <td>0</td> <td>0</td> </tr> <tr> <td>⋮</td> <td>⋮</td> <td>⋮</td> <td>⋮</td> <td>⋮</td> </tr> <tr> <td>1</td> <td>0</td> <td>1</td> <td>1</td> <td>0</td> </tr> <tr> <td>0</td> <td>1</td> <td>1</td> <td>1</td> <td>0</td> </tr> <tr> <td>1</td> <td>1</td> <td>1</td> <td>1</td> <td>1</td> </tr> </tbody> </table>		IN1	IN2	IN3	IN4	OUT	0	0	0	0	0	1	0	0	0	0	0	1	0	0	0	⋮	⋮	⋮	⋮	⋮	1	0	1	1	0	0	1	1	1	0	1	1	1	1	1
IN1	IN2	IN3			IN4	OUT																																						
0	0	0			0	0																																						
1	0	0	0	0																																								
0	1	0	0	0																																								
⋮	⋮	⋮	⋮	⋮																																								
1	0	1	1	0																																								
0	1	1	1	0																																								
1	1	1	1	1																																								
Work Area																																												
Limitation on Usage																																												

◎: Signed 4-byte data; ○: Signed 2-byte data; ●: Flag of 0 or 1; ×: No output

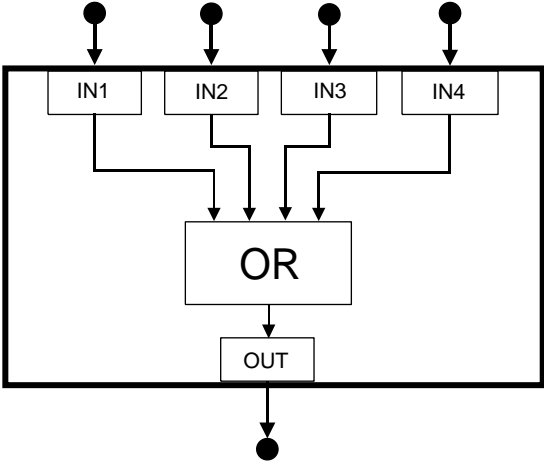
Module No.	<b>15</b>		Category	Logical Operation																																								
Module Name	OR Logic		Module Code Name	<b>OR</b>																																								
Module Input			<p><b>[Computational Expression]</b>  <math>OUT = IN1 \vee IN2 \vee IN3 \vee IN4</math></p> 																																									
IN1	●	Input 1																																										
IN2	●	Input 2																																										
IN3	●	Input 3																																										
IN4	●	Input 4																																										
IN5																																												
IN6																																												
IN7																																												
IN8																																												
Module Parameter																																												
P1																																												
P2																																												
P3																																												
P4																																												
Module Output																																												
OUT	●	OR logic result	<p><b>[Explanation]</b>                      The module outputs the OR logic for IN1 to IN4.                      Example: <math>1 = 1 \vee 0 \vee 0 \vee 1</math></p> <table border="1" data-bbox="751 898 1050 1167"> <thead> <tr> <th>IN1</th> <th>IN2</th> <th>IN3</th> <th>IN4</th> <th>OUT</th> </tr> </thead> <tbody> <tr> <td>0</td> <td>0</td> <td>0</td> <td>0</td> <td>0</td> </tr> <tr> <td>1</td> <td>0</td> <td>0</td> <td>0</td> <td>1</td> </tr> <tr> <td>0</td> <td>1</td> <td>0</td> <td>0</td> <td>1</td> </tr> <tr> <td>⋮</td> <td>⋮</td> <td>⋮</td> <td>⋮</td> <td>⋮</td> </tr> <tr> <td>1</td> <td>0</td> <td>1</td> <td>1</td> <td>1</td> </tr> <tr> <td>0</td> <td>1</td> <td>1</td> <td>1</td> <td>1</td> </tr> <tr> <td>1</td> <td>1</td> <td>1</td> <td>1</td> <td>1</td> </tr> </tbody> </table>		IN1	IN2	IN3	IN4	OUT	0	0	0	0	0	1	0	0	0	1	0	1	0	0	1	⋮	⋮	⋮	⋮	⋮	1	0	1	1	1	0	1	1	1	1	1	1	1	1	1
IN1	IN2	IN3			IN4	OUT																																						
0	0	0			0	0																																						
1	0	0	0	1																																								
0	1	0	0	1																																								
⋮	⋮	⋮	⋮	⋮																																								
1	0	1	1	1																																								
0	1	1	1	1																																								
1	1	1	1	1																																								
Work Area																																												
Limitation on Usage																																												

◎: Signed 4-byte data; ○: Signed 2-byte data; ●: Flag of 0 or 1; ×: No output

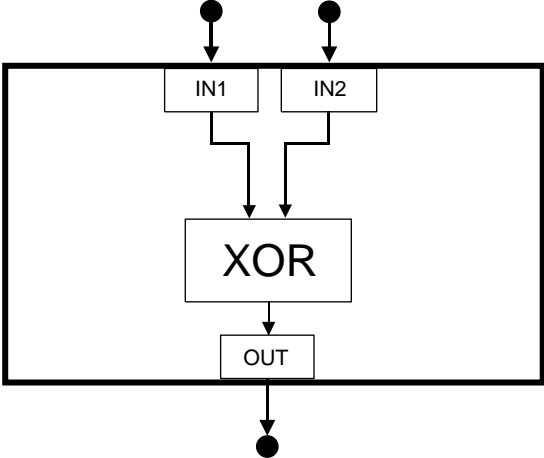
Module No.	<b>16</b>		Category	Logical Operation															
Module Name	XOR Logic		Module Code Name	<b>XOR</b>															
Module Input			<p><b>[Computational Expression]</b>  <math>OUT = IN1 \vee IN2</math></p> 																
IN1	●	Input 1																	
IN2	●	Input 2																	
IN3																			
IN4																			
IN5																			
IN6																			
IN7																			
IN8																			
Module Parameter																			
P1																			
P2																			
P3																			
P4																			
Module Output			<p><b>[Explanation]</b>                  The module outputs the exclusive OR logic for IN1 and IN2.                  Example: <math>1 = 1 \vee 0</math>, <math>0 = 1 \vee 1</math></p> <table border="1" data-bbox="751 896 933 1041"> <thead> <tr> <th>IN1</th> <th>IN2</th> <th>OUT</th> </tr> </thead> <tbody> <tr> <td>0</td> <td>0</td> <td>0</td> </tr> <tr> <td>0</td> <td>1</td> <td>1</td> </tr> <tr> <td>1</td> <td>0</td> <td>1</td> </tr> <tr> <td>1</td> <td>1</td> <td>0</td> </tr> </tbody> </table>		IN1	IN2	OUT	0	0	0	0	1	1	1	0	1	1	1	0
IN1	IN2	OUT																	
0	0	0																	
0	1	1																	
1	0	1																	
1	1	0																	
OUT	●	Exclusive OR logic result																	
Work Area																			
Limitation on Usage																			

◎: Signed 4-byte data; ○: Signed 2-byte data; ●: Flag of 0 or 1; ×: No output

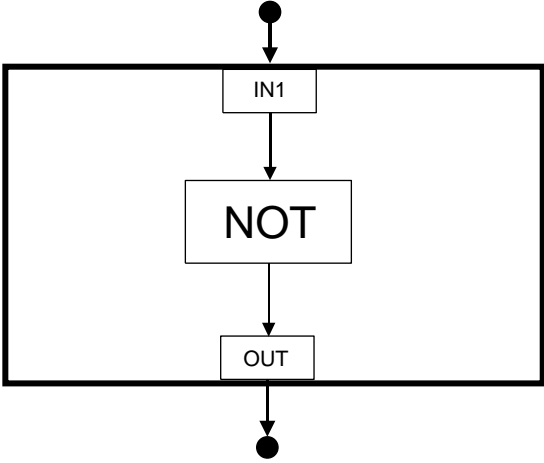
Module No.	<b>17</b>		Category	Logical Operation					
Module Name	NOT Logic		Module Code Name	<b>NOT</b>					
Module Input			<p><b>[Computational Expression]</b>  <math>OUT = \overline{IN1}</math></p>  <pre> graph TD     In(( )) --&gt; IN1[IN1]     IN1 --&gt; NOT[NOT]     NOT --&gt; OUT[OUT]     OUT --&gt; Out(( ))             </pre>						
IN1	●	Input 1							
IN2									
IN3									
IN4									
IN5									
IN6									
IN7									
IN8									
Module Parameter									
P1									
P2									
P3									
P4									
Module Output									
OUT	●	NOT logic result							
Work Area									
Limitation on Usage									
			<p><b>[Explanation]</b>                  The module outputs the value of IN1 after inverting it.</p> <p>Example: <math>1 = \overline{0}</math>, <math>0 = \overline{1}</math></p> <table border="1" data-bbox="751 891 874 981"> <thead> <tr> <th>IN1</th> <th>OUT</th> </tr> </thead> <tbody> <tr> <td>0</td> <td>1</td> </tr> <tr> <td>1</td> <td>0</td> </tr> </tbody> </table>	IN1	OUT	0	1	1	0
IN1	OUT								
0	1								
1	0								

◎: Signed 4-byte data; ○: Signed 2-byte data; ●: Flag of 0 or 1; ×: No output

Module No.	<b>18</b>		Category	Logical Operation
Module Name	Latch		Module Code Name	<b>LATCH</b>
Module Input			<p><b>[Computational Expression]</b>                  If P1 = 1, then OUT = 0                  If P1 = 0, then: OUT = 1 for IN1 = 1                  OUT = previous OUT for IN1 = 0</p>	
IN1	●	Input 1		
IN2				
IN3				
IN4				
IN5				
IN6				
IN7				
IN8				
Module Parameter				
P1	●	Initialization flag		
P2				
P3				
P4				
Module Output				
OUT	●	Latched output		
Work Area	4			
Limitation on Usage				
			<p><b>[Explanation]</b>                  The module locks the value of IN1 at 1 for output.</p>	
			<p><b>[TIP]</b>                  P1: Initialization flag (P1 = 1: initialization)</p>	
			<p><b>[NOTE]</b>                  The value of OUT is reset to 0 upon power failure.</p>	

◎: Signed 4-byte data; ○: Signed 2-byte data; ●: Flag of 0 or 1; ×: No output

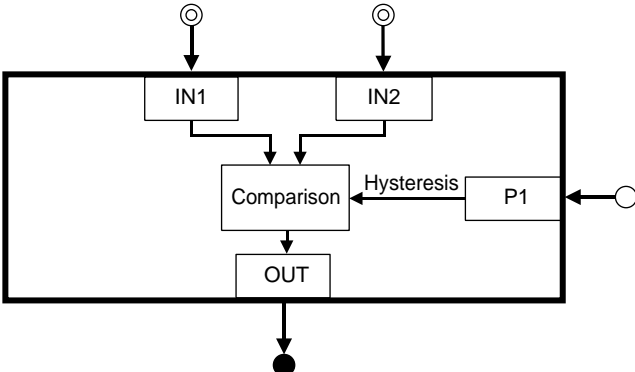
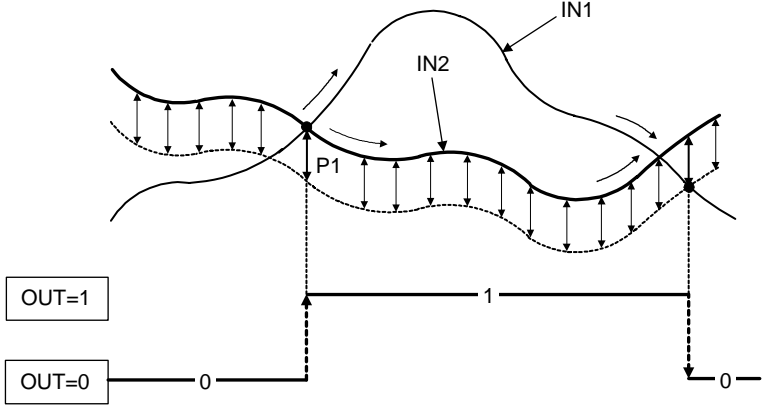
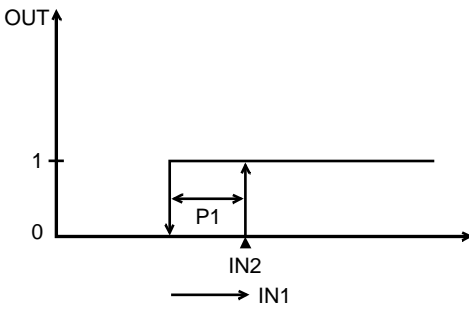
Module No.	<b>19</b>		Category	Logical Operation
Module Name	Greater-than Logic		Module Code Name	<b>GT</b>
Module Input			<p><b>[Computational Expression]</b>                  If <math>IN1 \geq IN2</math>, then <math>OUT = 1</math>; if <math>IN1 &lt; IN2 - P1</math>, then <math>OUT = 0</math>;                  if <math>IN2 - P1 \leq IN1 &lt; IN2</math>, the module retains the previous output.</p> 	
IN1	⊙	Input 1		
IN2	⊙	Input 2		
IN3				
IN4				
IN5				
IN6				
IN7				
IN8				
Module Parameter			<p><b>[Explanation]</b>                  The module outputs 1 if <math>IN1</math> is greater than <math>IN2</math>.                  The module outputs 0 if <math>IN1</math> is less than <math>(IN2 - P1)</math>.</p> 	
P1	○	Hysteresis		
P2				
P3				
Module Output				
OUT	●	Result of comparison		
Work Area	1			
Limitation on Usage				

⊙: Signed 4-byte data; ○: Signed 2-byte data; ●: Flag of 0 or 1; ×: No output

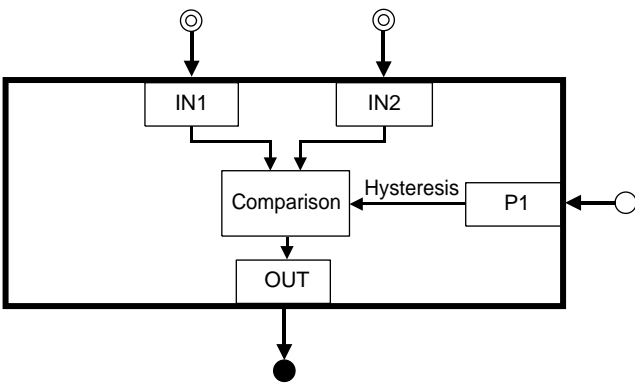
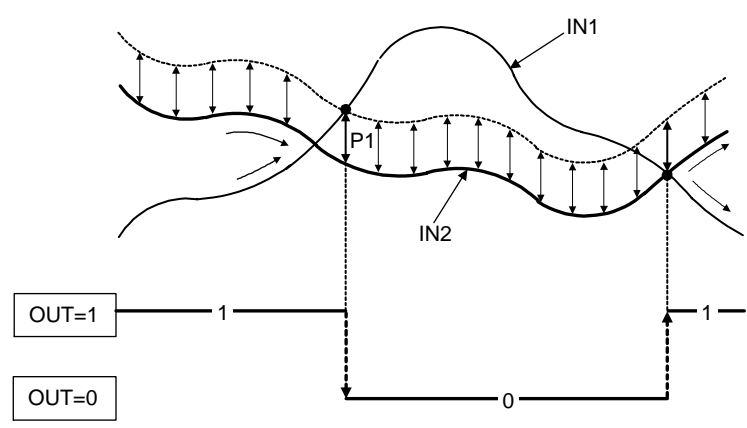
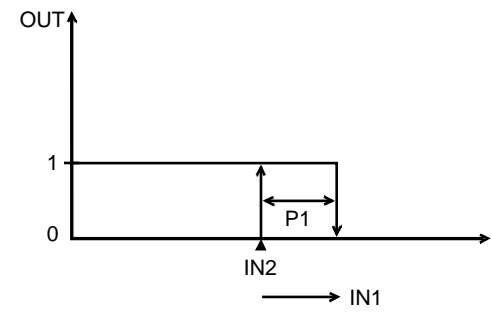
Module No.	<b>20</b>		Category	Logical Operation
Module Name	Less-than Logic		Module Code Name	<b>LT</b>
Module Input			<p><b>[Computational Expression]</b>                  If <math>IN1 \leq IN2</math>, then <math>OUT = 1</math>; if <math>IN1 &gt; IN2 + P1</math>, then <math>OUT = 0</math>;                  if <math>IN2 &lt; IN1 \leq IN2 + P1</math>, the module retains the previous output</p> 	
IN1	⊙	Input 1		
IN2	⊙	Input 2		
IN3				
IN4				
IN5				
IN6				
IN7				
IN8				
Module Parameter			<p><b>[Explanation]</b>                  The module outputs 1 if <math>IN1</math> is less than <math>IN2</math>.                  The module outputs 0 if <math>IN1</math> is greater than <math>(IN2 + P1)</math>.</p> 	
P1	○	Hysteresis		
P2				
P3				
Module Output				
OUT	●	Result of comparison		
Work Area		1		
Limitation on Usage				

⊙: Signed 4-byte data; ○: Signed 2-byte data; ●: Flag of 0 or 1; ×: No output

Module No.	<b>21</b>		Category	Logical Operation
Module Name	Decremental Counter		Module Code Name	<b>DCOUNTER</b>
Module Input			<p><b>[Computational Expression]</b>                      If IN3 changes (from 0 to 1 or from 1 to 0), then OUT = previous OUT + 1.                      Otherwise, OUT = previous OUT.</p>	
IN1	●	Enable flag		
IN2	●	Initialization flag		
IN3	●	Decrement flag		
IN4	○	Initial value		
IN5				
IN6				
IN7				
IN8				
Module Parameter				
P1	●	Auto-initialization selection flag		
P2				
P3				
P4				
Module Output				
OUT	○	Current counter value		
Work Area	3			
Limitation on Usage				
			<p><b>[Explanation]</b>                      The module sets IN4 in the decremental counter if IN2 = 1, where OUT = initial value (irrelevant of the IN1 value).                      The output is enabled if IN1 = 1, and the module counts down if IN3 changes (from 0 to 1 or from 1 to 0).                      The output is disabled if IN1 = 0 and does not change for as long as IN1 = 0, even if IN3 changes.</p> <p>If P1 = 0, the decremental counter stops when it reaches 0.                      If P1 = 1, the initial value is set in the decremental counter when it reaches 0, resulting in a change in the initialization flag; which allows the counter to resume operation.</p> <p><b>[TIP]</b>                      IN1: Enable flag (IN1 = 0: Stop counting momentarily; IN1 = 1: Continue counting)                      IN2: Initialization flag (IN2 = 0: Do not initialize; IN2 = 1: Initialize the count)</p> <p><b>[NOTE]</b>                      The value of OUT is reset to 0 upon power failure.</p>	
			<p>◎: Signed 4-byte data; ○: Signed 2-byte data; ●: Flag of 0 or 1; ×: No output</p>	



Module No.	<b>21</b>	Category	Logical Operation
Module Name	Decremental Counter	Module Code Name	<b>DCOUNTER</b>

**[Example of Use]**

- Behavior of the decremental counter when automatic initialization is carried out

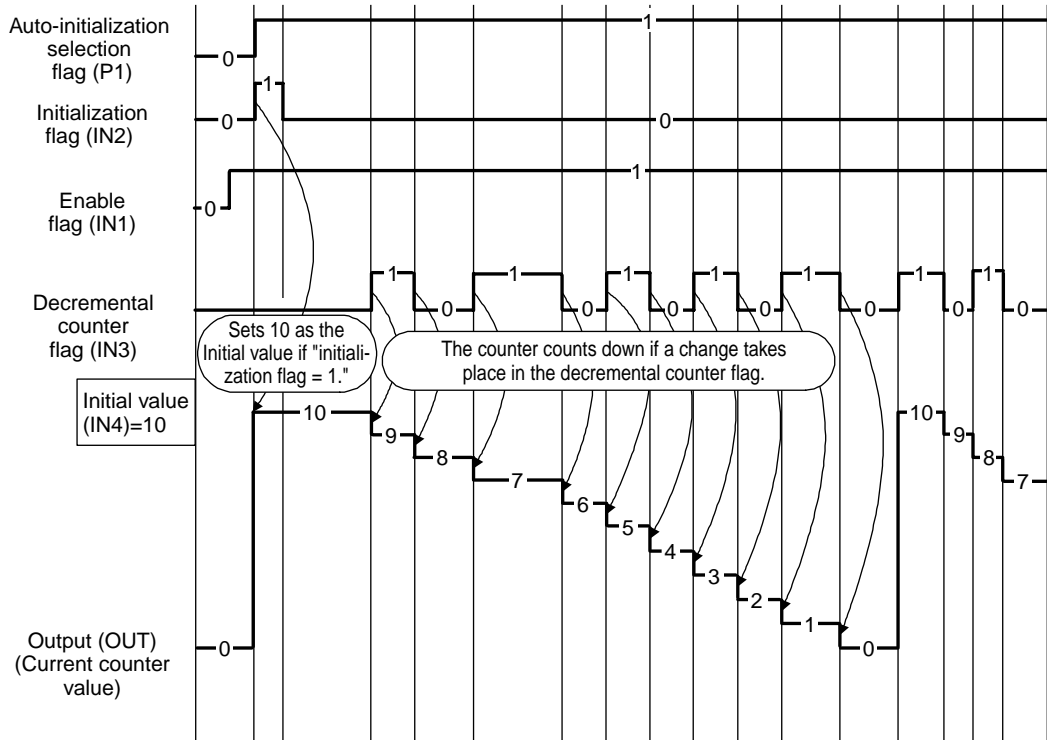

◎: Signed 4-byte data; ○: Signed 2-byte data; ●: Flag of 0 or 1; ×: No output

Module No.	<b>22</b>		Category	Logical Operation
Module Name	Counter		Module Code Name	<b>COUNTER</b>
Module Input			<p><b>[Computational Expression]</b>                  If IN3 changes (from 0 to 1 or from 1 to 0), then OUT = previous OUT + 1                  Otherwise, OUT = previous OUT</p>	
IN1	●	Enable flag		
IN2	●	Reset flag		
IN3	●	Increment flag		
IN4				
IN5				
IN6				
IN7				
IN8				
Module Parameter				
P1	●	Auto-initialization selection flag		
P2				
P3				
P4				
Module Output				
OUT	○	Current counter value		
Work Area	3			
Limitation on Usage				
			<p><b>[Explanation]</b>                  The module resets the counter if IN2 = 1, where OUT = 0 (irrelevant of the IN1 value).                  The output is enabled if IN1 = 1, and the module counts up if IN3 changes.                  The output is disabled if IN1 = 0 and does not change for as long as IN1 = 0, even if IN3 changes.</p> <p>If P1 = 0, the counter stops when it reaches 0FFFFh (65535 in the decimal system).                  If P1 = 1, the counter resets to 0 after it reaches 0FFFFh, and resumes counting.</p> <p><b>[TIP]</b>                  IN1: Enable flag (IN1 = 0: Stop counting momentarily; IN1 = 1: Continue counting)                  IN2: Initialization flag (IN2 = 0: Do not initialize flag; IN2 = 1: Initialize the count)</p> <p><b>[NOTE]</b>                  The value of OUT is reset to 0FFFFh (= 65535 in decimal notation) upon power failure.</p>	
			<p>◎ : Signed 4-byte data; ○ : Signed 2-byte data; ● : Flag of 0 or 1; × : No output</p>	

Module No.	<b>22</b>	Category	Logical Operation
Module Name	Counter	Module Code Name	<b>COUNTER</b>

[Example of Use]

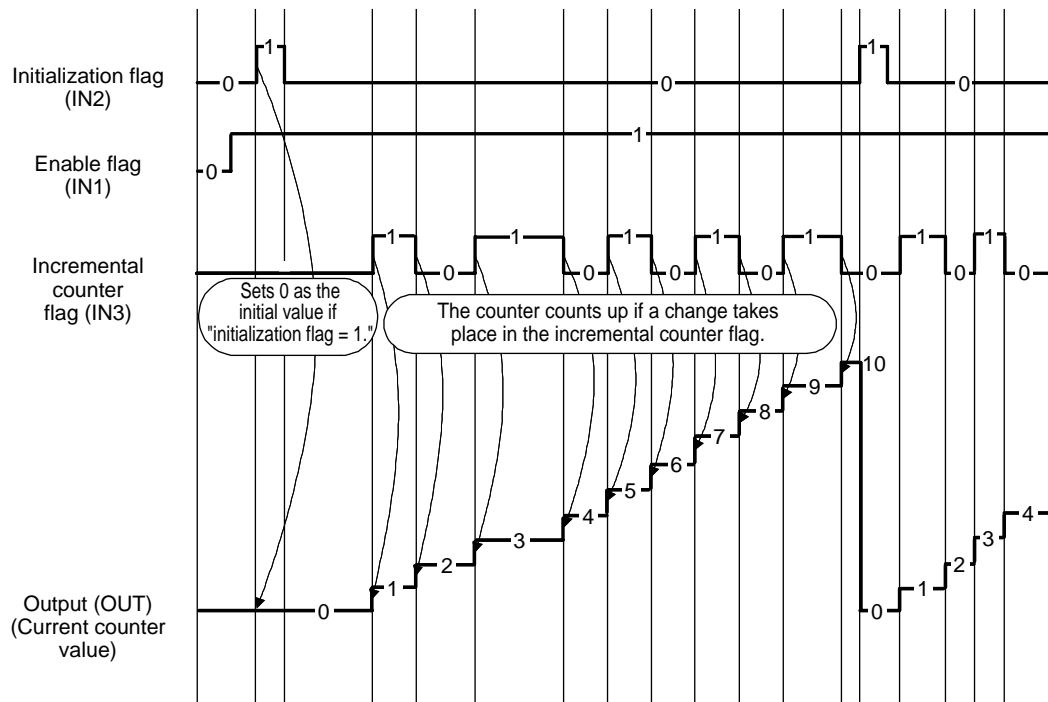

◎: Signed 4-byte data; ○: Signed 2-byte data; ●: Flag of 0 or 1; ×: No output

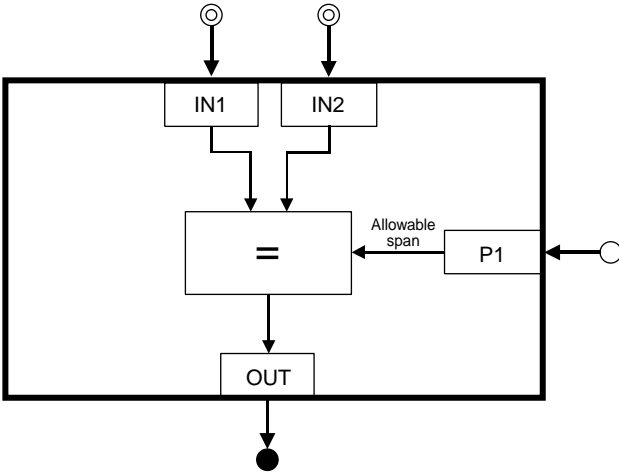
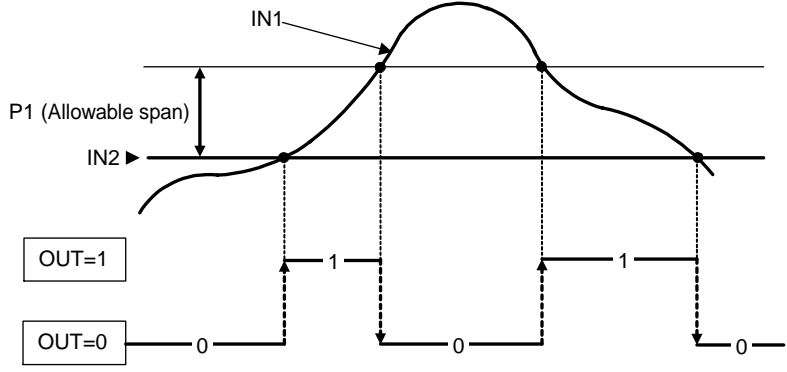
Module No.	<b>23</b>		Category	Logical Operation
Module Name	Equal-to Logic		Module Code Name	<b>EQ</b>
Module Input			<p><b>[Computational Expression]</b>                  If <math>IN2 \leq IN1 \leq (IN2 + P1)</math>, then <math>OUT = 1</math>                  Otherwise, <math>OUT = 0</math></p> 	
IN1	⊙	Input 1		
IN2	⊙	Input 2		
IN3				
IN4				
IN5				
IN6				
IN7				
IN8				
Module Parameter				
P1	○	Allowable span		
P2				
P3				
P4				
Module Output				
OUT	●	Result of comparison		
Work Area				
Limitation on Usage				
			<p><b>Illustrated Explanation</b></p> 	
			<p><b>[Example]</b> <math>IN1=250, IN2=240, P1=20</math>                  When <math>240 \leq 250 \leq (240+20)</math>, <math>OUT=1</math>.</p>	
<p>⊙: Signed 4-byte data; ○: Signed 2-byte data; ●: Flag of 0 or 1; ×: No output</p>				

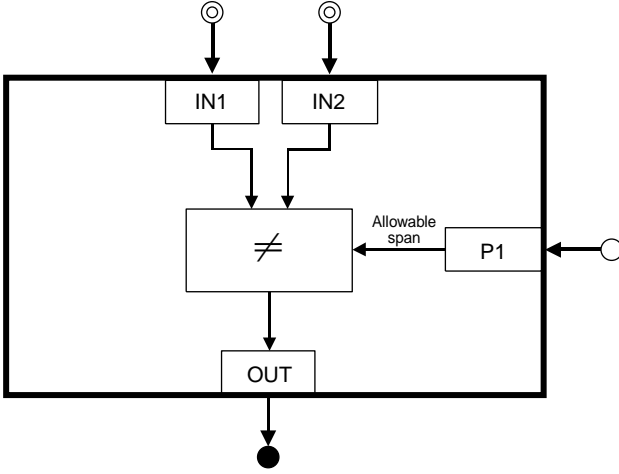
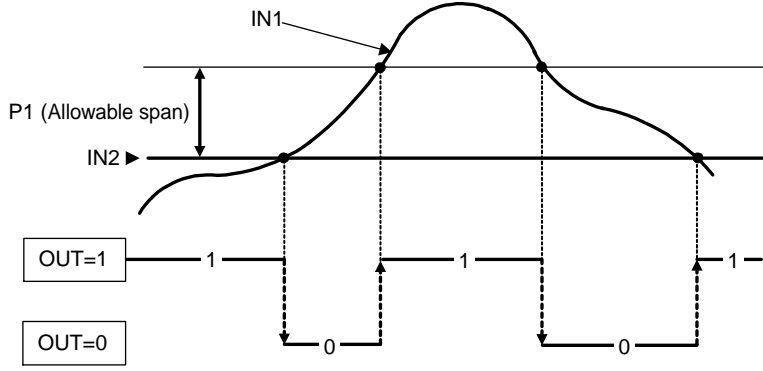
Module No.	<b>24</b>		Category	Logical Operation
Module Name	Not-Equal-to Logic		Module Code Name	<b>NEQ</b>
Module Input			<p><b>[Computational Expression]</b>                  If <math>IN1 \cong IN2</math> or <math>(IN2 + P1) \cong IN1</math>, then <math>OUT = 1</math>.                  Otherwise, <math>OUT = 0</math></p> 	
IN1	⊙	Input 1		
IN2	⊙	Input 2		
IN3				
IN4				
IN5				
IN6				
IN7				
IN8				
Module Parameter				
P1	○	Allowable span		
P2				
P3				
P4				
Module Output				
OUT	●	Result of comparison		
Work Area				
Limitation on Usage				
			<p><b>Illustrated Explanation</b></p> 	
			<p><b>[Example]</b> When <math>IN1=250</math>, <math>IN2=240</math>, and <math>P1=20</math>,  <math>240 \cong 250 \cong (240+20)</math>; therefore <math>OUT=0</math></p>	
			<p>⊙: Signed 4-byte data; ○: Signed 2-byte data; ●: Flag of 0 or 1; ×: No output</p>	

Module No.	<b>25</b>		Category	Logical Operation
Module Name	Range Logic		Module Code Name	<b>RANGE</b>
Module Input			<p><b>[Computational Expression]</b>                  If <math>P2 \leq IN1 \leq P1</math>, then <math>OUT = 1</math>                  Otherwise, <math>OUT = 0</math></p>	
IN1	⊙	Input 1		
IN2				
IN3				
IN4				
IN5				
IN6				
IN7				
IN8				
Module Parameter				
P1	⊙	Setting value of upper limit		
P2	⊙	Setting value of lower limit		
P3				
P4				
Module Output				
OUT	●	Result of comparison		
Work Area				
Limitation on Usage				
			<p><b>Illustrated Explanation</b></p>	
⊙: Signed 4-byte data;   ○: Signed 2-byte data;   ●: Flag of 0 or 1;   ×: No output				

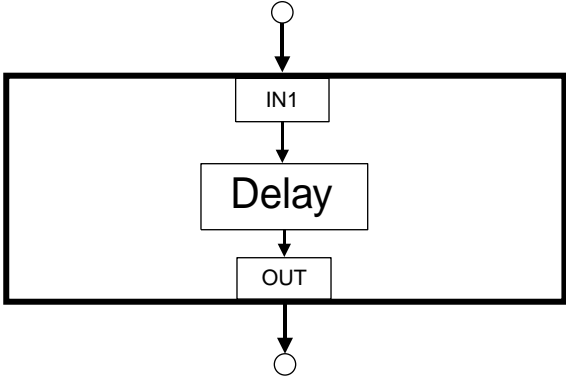
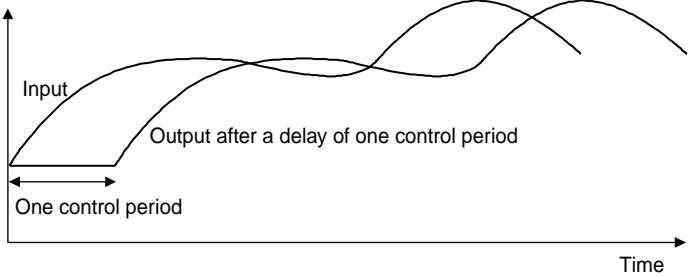
Module No.	<b>26</b>		Category	Logical Operation
Module Name	Delay Logic		Module Code Name	<b>DELAY</b>
Module Input			<b>[Computational Expression]</b> OUT = previous IN1 (output after a delay of one control period)	
IN1	<input type="radio"/>	Input 1		
IN2				
IN3				
IN4				
IN5				
IN6				
IN7				
IN8				
Module Parameter			<b>[Explanation]</b> The module outputs the value of IN1 after a delay of one control period. Use this module to set a delay between specific processes.	
P1				
P2				
P3				
P4				
Module Output			<b>[See Also]</b> UP750 User's Manual for Single-loop Control (IM 05E01B02-01E to -07E), for information on control period.	
OUT	<input type="radio"/>	Delayed output		
Work Area	2			
Limitation on Usage				

⊙: Signed 4-byte data; ○: Signed 2-byte data; ●: Flag of 0 or 1; ×: No output

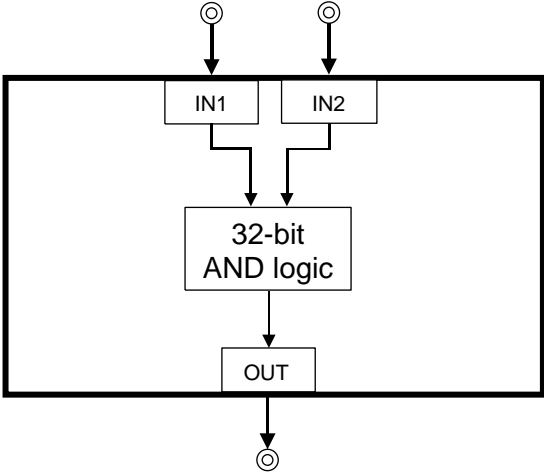
Module No.	<b>27</b>		Category	Logical Operation
Module Name	AND (Long Word) Logic		Module Code Name	<b>ANDW</b>
Module Input			<p><b>[Computational Expression]</b>  <math>OUT = IN1 \wedge IN2</math></p> 	
IN1	⊙	Input 1		
IN2	⊙	Input 2		
IN3				
IN4				
IN5				
IN6				
IN7				
IN8				
Module Parameter				
P1				
P2				
P3				
P4				
Module Output				
OUT	⊙	AND (Long word) logic result	<p><b>[Explanation]</b>                      The module outputs the AND logic for IN1 and IN2 in long word (32 bits) units.</p> <p><b>Example of Operation</b></p> <pre>                     IN1  1 0 1 0 0 1 0 1 0 1 0 1 1 1 1 0 0 0 1 0 1 0 0 0 1 1 1 1 0 1 0 1                     AND                     IN2  0 0 1 0 0 0 0 0 0 0 0 0 0 0 0 1 1 0 0 1 0 0 0 0 1 0 1 1 0 0 0                     ↓                     OUT  0 0 1 0 0 0 0 0 0 0 0 0 0 0 0 0 0 1 0 0 0 0 1 0 0 0 1 0 1 0 0 0                     </pre>	
Work Area				
Limitation on Usage				

⊙: Signed 4-byte data; ○: Signed 2-byte data; ●: Flag of 0 or 1; ×: No output

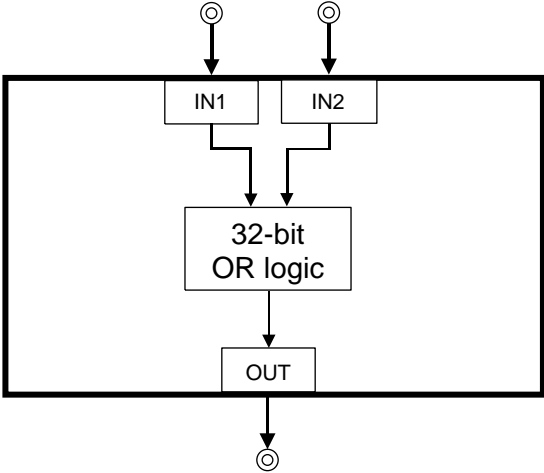

Module No.	<b>28</b>		Category	Logical Operation
Module Name	OR (Long Word) Logic		Module Code Name	<b>ORW</b>
Module Input			<p><b>[Computational Expression]</b>  <math>OUT = IN1 \vee IN2</math></p> 	
IN1	⊙	Input 1		
IN2	⊙	Input 2		
IN3				
IN4				
IN5				
IN6				
IN7				
IN8				
Module Parameter				
P1				
P2				
P3				
P4				
Module Output				
OUT	⊙	OR (Long word) logic result	<p><b>[Explanation]</b>                      The module outputs the OR logic of IN1 and IN2 in long word (32 bits) units.</p> <p><b>Example of Operation</b></p> <pre>                     IN1  1 0 1 0 0 1 0 1 0 1 0 1 1 1 1 0 0 0 1 0 1 0 0 0 1 1 1 1 0 1 0 1                     OR                     IN2  0 0 1 0 0 0 0 0 0 0 0 0 0 0 1 1 0 0 1 0 0 0 0 1 0 1 1 0 0 0                     ↓                     OUT  1 0 1 0 0 1 0 1 0 1 0 1 1 1 1 0 1 1 1 0 1 0 0 0 1 1 1 1 1 0 1                     </pre>	
Work Area				
Limitation on Usage				

⊙: Signed 4-byte data; ○: Signed 2-byte data; ●: Flag of 0 or 1; ×: No output

Module No.	<b>29</b>		Category	Logical Operation
Module Name	Word Shift		Module Code Name	<b>SHIFT</b>
Module Input			<p><b>[Explanation]</b> The module outputs IN1 after shifting as many bits as specified in P1.</p>	
IN1	<input checked="" type="radio"/>	Input 1		
IN2	<input type="radio"/>			
IN3	<input type="radio"/>			
IN4	<input type="radio"/>			
IN5	<input type="radio"/>			
IN6	<input type="radio"/>			
IN7	<input type="radio"/>			
IN8	<input type="radio"/>			
Module Parameter				
P1	<input type="radio"/>	Number of bits shifted (-32 to 32)		
P2	<input type="radio"/>	Selection of sign (0, 1)		
P3	<input type="radio"/>			
P4	<input type="radio"/>			
Module Output			<p><b>[TIP]</b> P1: Number of bits shifted (-32 to 32) P2: Selection of sign (P2 = 0: Unsigned; P2 = 1: Signed)</p>	
OUT	<input checked="" type="radio"/>	Result of word shift		
Work Area				
Limitation on Usage				

⊙: Signed 4-byte data; ○: Signed 2-byte data; ●: Flag of 0 or 1; ×: No output

Module No.	<b>30</b>		Category	Special Operation
Module Name	Sum		Module Code Name	<b>SUM</b>
Module Input			<p><b>[Computational Expression]</b>  <math>OUT = \text{previous } OUT + IN1</math></p>	
IN1	⊙	Input 1		
IN2	⊙	Initial value		
IN3				
IN4				
IN5				
IN6				
IN7				
IN8				
Module Parameter				
P1	●	Initialization flag		
P2				
P3				
P4				
Module Output				
OUT	⊙	Sum		
Work Area	4			
Limitation on Usage				
			<p><b>[Explanation]</b>                      The module calculates the sum of IN1.                      IN1 can be either positive or negative.                      If P1 = 1, then OUT = IN2.                      The module limits IN1 to the maximum value if it overflows on the positive side.                      The module limits IN1 to the minimum value if it overflows on the negative side.</p>	
			<p><b>[NOTE]</b>                      The value of OUT is reset to 0 upon power failure.</p>	

⊙: Signed 4-byte data; ○: Signed 2-byte data; ●: Flag of 0 or 1; ×: No output

Module No.	<b>31</b>		Category	Special Operation
Module Name	Timer		Module Code Name	<b>TIMER</b>
Module Input			<p><b>[Explanation]</b> The module sets OUT to 1 if the timer reaches 0. Otherwise, it sets OUT to 0.</p>	
IN1	●	Enable flag		
IN2	●	Initialization flag		
IN3	●	Timer flag		
IN4	○	Initial value		
IN5				
IN6				
IN7				
IN8				
Module Parameter				
P1	●	Auto-initialization selection flag		
P2				
P3				
P4				
Module Output				
OUT	●	Time-out flag		
Work Area	4			
Limitation on Usage				

If IN1 = 0, the timer stops.  
 If IN1 = 1, subtract 1 from timer value when IN3 changes (from 0 to 1 or vice versa).  
 If IN2 = 1, the timer value = IN4 (irrelevant of the IN1 value).

**[TIP]**  
 The timer value depends on the basic clock (timer flag) and control period.

**[See Also]**  
 UP750 User's Manual for Single-loop Control (IM 05E01B02-01E to -07E), for information on control period.

If P1 = 0, the timer stops when it reaches the end of operation and OUT is set to 1.  
 If P1 = 1, the timer is set to the Initial value when the timer reaches the end of operation resulting in a change in the timer flag and OUT is set to 1; thus, the timer resumes operation.

**[TIP]**  
 IN1: Enable flag (IN1 = 0: Stop timer operation; IN1 = 1: Continue timer operation)

**[NOTE]**  
 The value of OUT is reset to 0 upon power failure.

**[See Also]**  
 "Timer flag" – Subsection 5.15.3, "Timer Function".

◎: Signed 4-byte data; ○: Signed 2-byte data; ●: Flag of 0 or 1; ×: No output

Module No.	<b>31</b>	Category	Special Operation
Module Name	Timer	Module Code Name	<b>TIMER</b>

**Example of Operation**

The following figure shows the timing chart of a 4-second timer.

The timing chart shows an example when the control period is set to 200 ms.

In the example shown, a maximum error of no more than one second will occur since the timer value is decremented at either the rising or falling edge of each clock pulse.

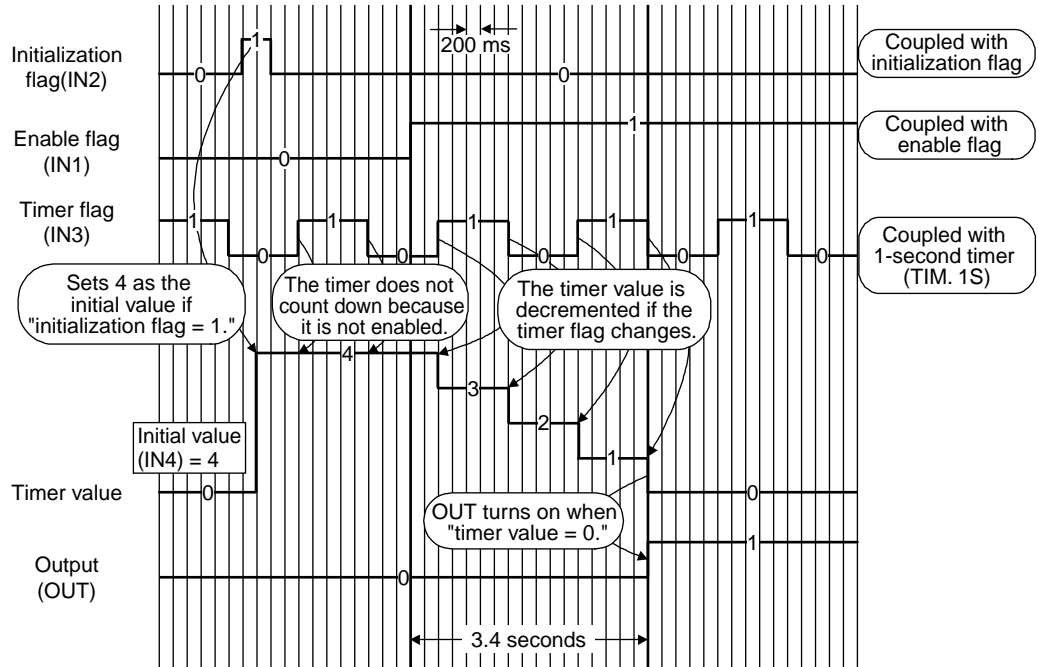

**Example of Operation**

The following figure shows the timing chart of a fixed interval 5-second timer that offers automatic initialization.

This timing chart shows an example of when the control period is set to 200 ms.

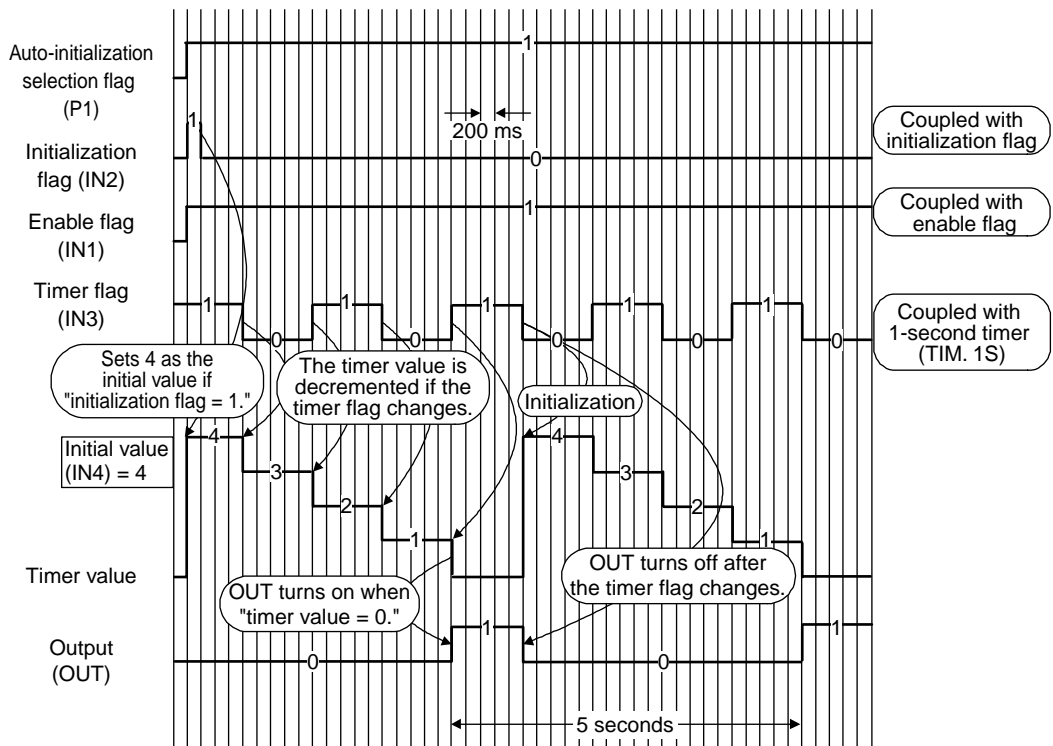

⊙: Signed 4-byte data; ○: Signed 2-byte data; ●: Flag of 0 or 1; ×: No output

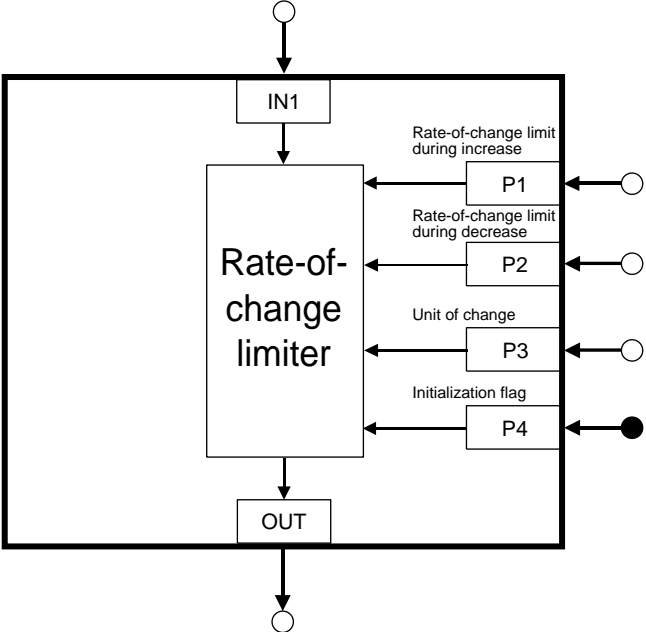
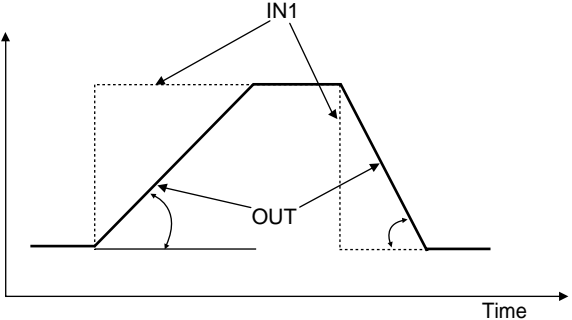
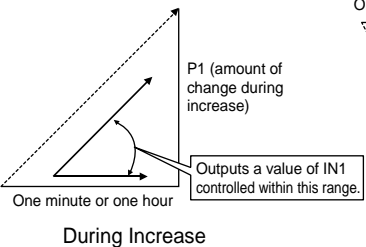
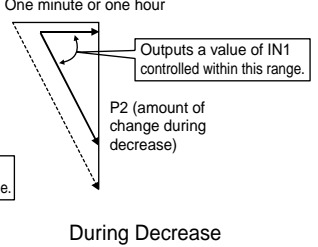
Module No.	<b>32</b>		Category	Special Operation
Module Name	Rate-of-change Limiter		Module Code Name	<b>CHGLMT</b>
Module Input			<p><b>[Explanation]</b> The module outputs a value of IN1 that is limited by P1 and P2 rate-of-change parameters.</p> 	
IN1	<input type="radio"/>	Input 1		
IN2				
IN3				
IN4				
IN5				
IN6				
IN7				
IN8				
Module Parameter				
P1	<input type="radio"/>	Rate-of-change limit during increase		
P2	<input type="radio"/>	Rate-of-change limit during decrease		
P3	<input type="radio"/>	Time unit of rate-of-change limitation		
P4	<input checked="" type="radio"/>	Initialization flag		
Module Output				
OUT	<input type="radio"/>	Output with limits		
Work Area	6			
Limitation on Usage				
<p><b>[TIP]</b>                      P1: Rate-of-change limit during increase; IN1 is controlled below this level.                      P2: Rate-of-change limit during decrease; IN1 is controlled below this level.                      P3: Time unit of rate-of-change limitation                      P3 = 0: hours                      P3 = 1: minutes                      P4: Initialization flag                      If P4 = 1, the module outputs the IN1 value as is.</p>   				

⊙: Signed 4-byte data; ○: Signed 2-byte data; ●: Flag of 0 or 1; ×: No output

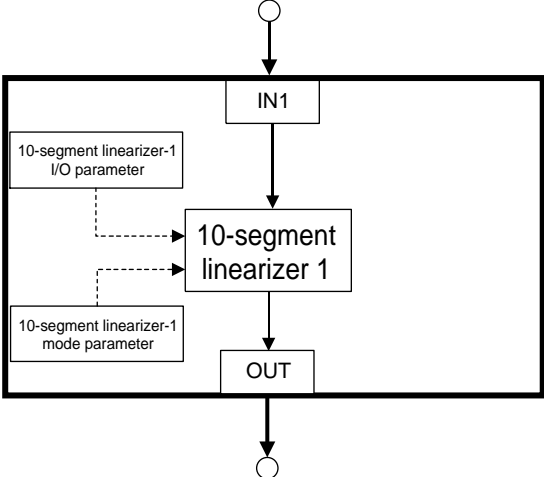
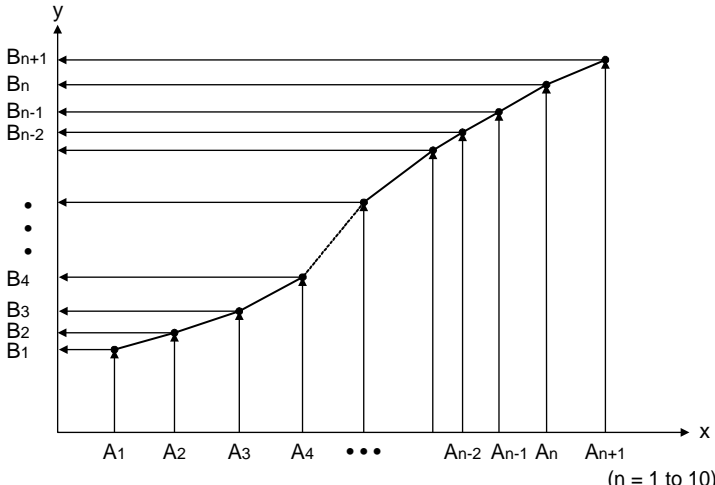
Module No.	<b>33</b>		Category	Special Operation
Module Name	10-segment Linearizer 1		Module Code Name	<b>PLINE1</b>
Module Input			<p><b>[Computational Expression]</b></p> <ul style="list-style-type: none"> <li>10-segment linearizer 1 approximation                      if <math>IN1 &lt; A_{11}</math> then <math>OUT = B_{11}</math>                      if <math>IN1 &gt; A_{11}</math> then <math>OUT = B_{11}</math>                      if <math>A_n \leq IN1 \leq A_{n+1}</math> then <math>OUT = B_n + (B_{n+1} - B_n) \times (IN1 - A_n) / (A_{n+1} - A_n)</math> where, <math>n = 1</math> to <math>10</math></li> <li>10-segment linearizer 1 biasing                      if 1.PMD = 0 then <math>OUT = OUT + IN1</math></li> </ul> <p><math>A_n</math>: Value of 10-segment linearizer 1 input parameter  <math>B_n</math>: Value of 10-segment linearizer 1 output parameter</p> 	
IN1	<input type="radio"/>	Input of 10-segment linearizer 1		
IN2				
IN3				
IN4				
IN5				
IN6				
IN7				
IN8				
Module Parameter				
P1				
P2				
P3				
P4				
Module Output				
OUT	<input type="radio"/>	Output of 10-segment linearizer 1		
Work Area				
Limitation on Usage				
			<p><b>[Explanation]</b>                      The module outputs a value of IN1 by linear approximation based on the table of 10-segment linearizer 1 (PYS1) parameters.</p> <p>1.PMD = 0: 10-segment linearizer 1 biasing                      1.PMD = 1: 10-segment linearizer 1 approximation</p> <p><b>[TIP]</b>                      1.PMD refers to the operation parameter.</p> <p>The following figure is an example of when linear approximation is applied.</p> 	
			<p><b>[See Also]</b>                      "10-segment Linearizer 2—PLINE2 (Module No. 34)" for information on 10-segment linearizer biasing</p>	

⊙: Signed 4-byte data; ○: Signed 2-byte data; ●: Flag of 0 or 1; ×: No output

Module No.	<b>34</b>		Category	Special Operation
Module Name	10-segment Linearizer 2		Module Code Name	<b>PLINE2</b>
Module Input			<p><b>[Computational Expression]</b></p> <ul style="list-style-type: none"> <li>10-segment linearizer 2 approximation                      if <math>IN1 &lt; A_{11}</math> then <math>OUT = B_1</math>                      if <math>IN1 &gt; A_{11}</math> then <math>OUT = B_{11}</math>                      if <math>A_n \leq IN1 \leq A_{n+1}</math> then <math>OUT = B_n + (B_{n+1} - B_n) \times (IN1 - A_n) / (A_{n+1} - A_n)</math> where, <math>n = 1</math> to <math>10</math></li> <li>10-segment linearizer 2 biasing                      if <math>2.PMD = 0</math> then <math>OUT = OUT + IN1</math></li> </ul> <p><math>A_n</math>: Value of 10-segment linearizer 2 input parameter  <math>B_n</math>: Value of 10-segment linearizer 2 output parameter</p>	
IN1	<input type="radio"/>	Input of 10-segment linearizer 2		
IN2				
IN3				
IN4				
IN5				
IN6				
IN7				
IN8				
Module Parameter				
P1				
P2				
P3				
Module Output			<p><b>[Explanation]</b>                      The module outputs a value of IN1 by linear approximation based on the table of 10-segment linearizer 2 (PYS2) parameters.</p> <p>2.PMD = 0: 10-segment linearizer 2 biasing                      2.PMD = 1: 10-segment linearizer 2 approximation</p> <p><b>[TIP]</b>                      2.PMD refers to the operation parameter.</p> <p>The following figure is an example of when line-segment biasing is applied.</p>	
OUT	<input type="radio"/>	Output of 10-segment linearizer 2		
Work Area				
Limitation on Usage			<p><b>[See Also]</b>                      "10-segment Linearizer 1—PLINE1 (Module No. 33)" for information on 10-segment linearizer approximation.</p>	

⊙: Signed 4-byte data; ○: Signed 2-byte data; ●: Flag of 0 or 1; ×: No output

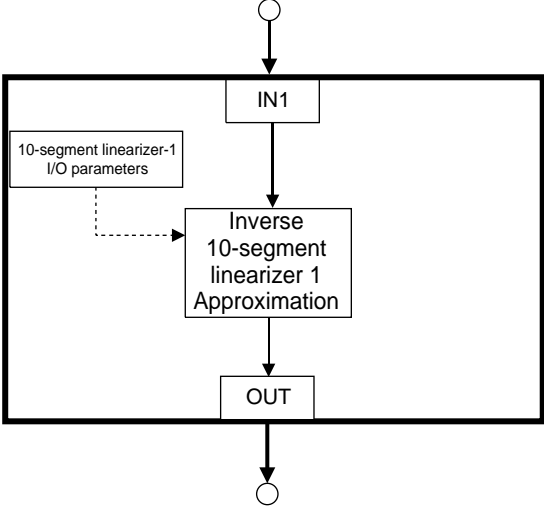
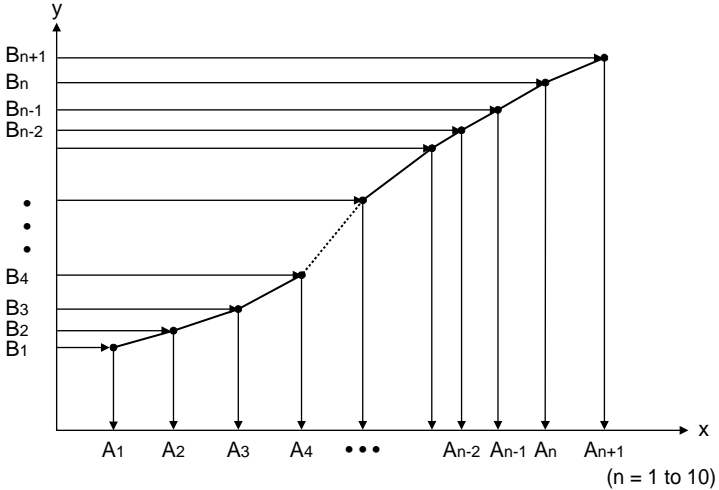

Module No.	<b>35</b>		Category	Special Operation
Module Name	Inverse 10-segment Linearizer 1 Approximation		Module Code Name	<b>ILINE1</b>
Module Input			<p><b>[Computational Expression]</b>                      if <math>IN1 &lt; B_1</math> then <math>OUT = A_1</math>                      if <math>IN1 &gt; B_{11}</math> then <math>OUT = A_{11}</math>                      if <math>B_n \leq IN1 \leq B_{n+1}</math> then <math>OUT = A_n + (A_{n+1} - A_n) \times (IN1 - B_n) / (B_{n+1} - B_n)</math> where, <math>n = 1</math> to <math>10</math></p> <p><math>A_n</math>: Value of 10-segment linearizer 1 input parameter  <math>B_n</math>: Value of 10-segment linearizer 1 output parameter</p> 	
IN1	<input type="radio"/>	Input of inverse 10-segment linearizer 1		
IN2				
IN3				
IN4				
IN5				
IN6				
IN7				
IN8				
Module Parameter				
P1				
P2				
P3				
P4				
Module Output				
OUT	<input type="radio"/>	Output of inverse 10-segment linearizer 1		
Work Area				
Limitation on Usage				
<p><b>[Explanation]</b>                      The module outputs the inverse of the value of 10-segment linearizer 1 (PLINE1).</p>  <p style="text-align: right;">(n = 1 to 10)</p>				
			<p><b>[TIP]</b>                      If the line segment does not represent a monotonically increasing function, the module takes the smaller of the two output values corresponding to the particular input level. In that case, the value may not match the input value of the PLINE1 module.</p>	
<p>⊙: Signed 4-byte data; ○: Signed 2-byte data; ●: Flag of 0 or 1; ×: No output</p>				

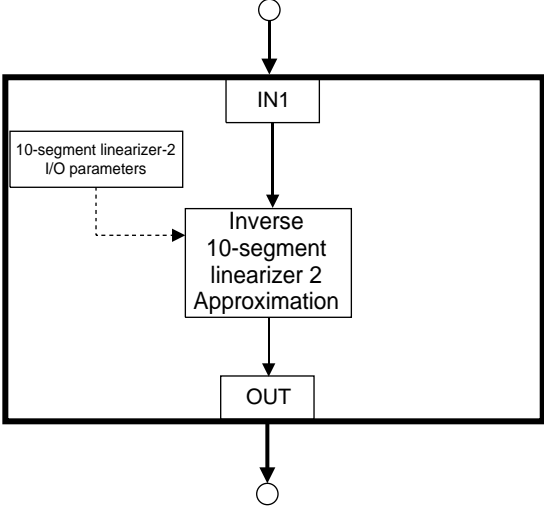
Module No.	<b>36</b>		Category	Special Operation
Module Name	Inverse 10-segment Linearizer 2 Approximation		Module Code Name	<b>ILINE2</b>
Module Input			<p><b>[Computational Expression]</b>                      if <math>IN1 &lt; B_1</math> then <math>OUT = A_1</math>                      if <math>IN1 &gt; B_{11}</math> then <math>OUT = A_{11}</math>                      if <math>B_n \leq IN1 \leq B_{n+1}</math> then <math>OUT = A_n + (A_{n+1} - A_n) \times (IN1 - B_n) / (B_{n+1} - B_n)</math> where, <math>n = 1</math> to <math>10</math></p> <p><math>A_n</math>: Value of 10-segment linearizer 2 input parameter  <math>B_n</math>: Value of 10-segment linearizer 2 output parameter</p> 	
IN1	<input type="radio"/>	Input of inverse 10-segment linearizer 2		
IN2				
IN3				
IN4				
IN5				
IN6				
IN7				
IN8				
Module Parameter				
P1				
P2				
P3				
P4				
Module Output				
OUT	<input type="radio"/>	Output of inverse 10-segment linearizer 2		
Work Area				
Limitation on Usage				
			<p><b>[Explanation]</b>                      The module outputs the inverse of the value of 10-segment linearizer 2 (PLINE2).</p> <p><b>[See Also]</b>                      Figure of inverse 10-segment linear approximation in "Inverse 10-segment Linearizer 1 Approximation"—ILINE1 Module (Module No. 35)</p> <p><b>[TIP]</b>                      If the line segment does not represent a monotonically increasing function, the module takes the smaller of the two output values corresponding to the particular input level. In that case, the value may not match the input value of the PLINE2 module.</p>	
<p>◎ : Signed 4-byte data; ○ : Signed 2-byte data; ● : Flag of 0 or 1; × : No output</p>				



Module No.	<b>38</b>		Category	Special Operation
Module Name	Curve Linearizer 2 Approximation		Module Code Name	<b>CURVE2</b>
Module Input			<p><b>[Computational Expression]</b>                      The module approximates the interval between points <math>P_n</math> and <math>P_{n+1}</math> (<math>X_n &lt; x \leq X_{n+1}</math>) by plotting it with four points in all, including an additional two points—one that immediately precedes <math>P_n</math> and the other that immediately follows <math>P_{n+1}</math> (i.e., <math>P_{n-1}</math> to <math>P_{n+2}</math>).</p> $y = ( ( d/X_{n+1} - X_n ) - 1) \times ( ( D_{n+1} - D_{n-1} ) / 2) + D_n \times d + Y_n$ $d = x - X_n$ $D_{n-1} = (Y_n - Y_{n-1}) / (X_n - X_{n-1})$ $D_n = (Y_{n+1} - Y_n) / (X_{n+1} - X_n)$ $D_{n+1} = (Y_{n+2} - Y_{n+1}) / (X_{n+2} - X_{n+1})$ <p>where,                      the intervals between <math>P_1</math> and <math>P_2</math> and between <math>P_{10}</math> and <math>P_{11}</math> at both ends of the curve are calculated by assuming <math>D_{n-1} = D_n</math> and <math>D_{n+1} = D_n</math>, respectively.</p>	
IN1	○	Input of curve linearizer 2		
IN2				
IN3				
IN4				
IN5				
IN6				
IN7				
IN8				
Module Parameter				
P1				
P2				
P3				
P4				
Module Output				
OUT	○	Output of curve linearizer 2		
Work Area				
Limitation on Usage				
			<pre>                     graph TD                         IN1((IN1)) --&gt; Box                         subgraph Box [Curve linearizer 2 Approximation]                             Params[10-segment linearizer-2 I/O parameters]                             Process[Curve linearizer 2 Approximation]                             Params -.-&gt; Process                         end                         Box --&gt; OUT((OUT))                     </pre>	
			<p><b>[Explanation]</b>                      The module outputs the value of IN1 obtained by curvilinear approximation based on the table of 10-segment linearizer 2 (PYS2) parameters.</p> <p><b>[See Also]</b>                      Figure of curvilinear approximation in "Curve Linearizer 1 Approximation"—CURVE1 Module (Module No. 37)</p>	

◎: Signed 4-byte data; ○: Signed 2-byte data; ●: Flag of 0 or 1; ×: No output

Module No.	<b>39</b>		Category	Special Operation
Module Name	Ratio		Module Code Name	<b>RATIO</b>
Module Input			<p><b>[Computational Expression]</b>  <math>OUT = (IN1 \times P1/P2) + P3</math></p>	
IN1	<input type="radio"/>	Input 1		
IN2				
IN3				
IN4				
IN5				
IN6				
IN7				
IN8				
Module Parameter				
P1	<input type="radio"/>	Coefficient 1		
P2	<input type="radio"/>	Coefficient 2		
P3	<input checked="" type="radio"/>	Coefficient 3		
P4				
Module Output				
OUT	<input checked="" type="radio"/>	Ratio calculation output		
Work Area				
Limitation on Usage				
			<p><b>[Explanation]</b>                  Divisions, additions and multiplications included in the computational expression comply with the specifications of the division, addition and multiplication modules. (The module outputs the maximum if the result of computation overflows on the positive side, or the minimum if the result overflows on the negative side.)</p> <p><b>[Example]</b></p> <p>*Register the D register number of U1 in P1.                  U1 specifies decimal point position when the parameter setting tool is used.                  U1(ABS3)=1.500(actual value)</p>	

⊙: Signed 4-byte data; ○: Signed 2-byte data; ●: Flag of 0 or 1; ×: No output

Module No.	<b>40</b>		Category	Special Operation
Module Name	First-order-lag Filter		Module Code Name	<b>FILTER</b>
Module Input			<p><b>[Computational Expression]</b>  <math>OUT = \text{previous } OUT + (IN1 - \text{previous } OUT) / (1 + P1 / \text{control period})</math></p>	
IN1	<input type="radio"/>	Input 1		
IN2				
IN3				
IN4				
IN5				
IN6				
IN7				
IN8				
Module Parameter				
P1	<input type="radio"/>	Time constant		
P2	<input checked="" type="radio"/>	Initialization flag		
P3				
P4				
Module Output				
OUT	<input type="radio"/>	First-order-lag output		
Work Area	4			
Limitation on Usage				
			<p><b>[Explanation]</b>                      If P1 = 0, the filter turns off and <math>OUT_n = IN1</math>.                      If P1 = 1 to 120 seconds, the module works as a first-order-lag filter.                      If P1 <math>\neq</math> 1 to 120 seconds, the filter turns off and <math>OUT_n = IN1</math>.                      If P2 = 1, then <math>OUT = IN1</math>.</p> <div style="display: flex; justify-content: space-around;"> <div style="text-align: center;"> <p>When non-processed input is applied</p> </div> <div style="text-align: center;"> <p>When the time constant is relatively small</p> </div> <div style="text-align: center;"> <p>When the time constant is relatively large</p> </div> </div> <p><b>[NOTE]</b>                      The value of OUT is reset to 0 upon power failure. Normally, connect the power-on flag (PON.st: I672) to the initialization flag.</p>	
<p>⊙: Signed 4-byte data; ○: Signed 2-byte data; ●: Flag of 0 or 1; ×: No output</p>				

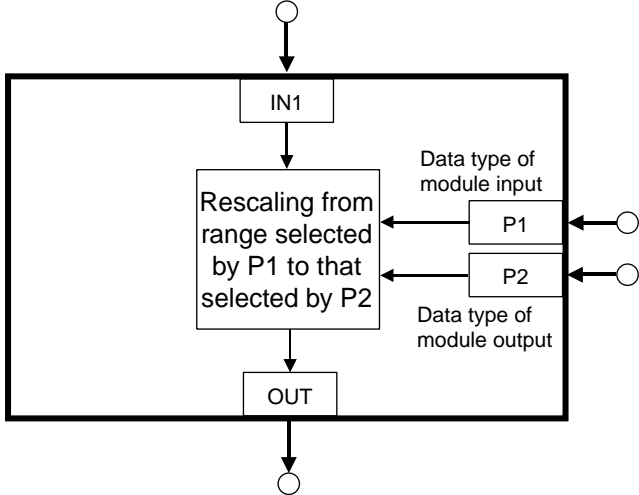
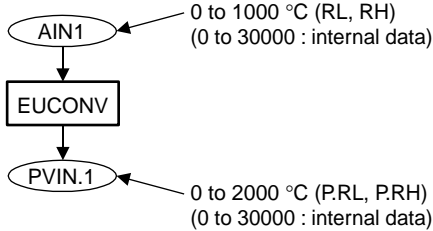
Module No.	<b>41</b>		Category	Special Operation
Module Name	EU Range Conversion		Module Code Name	<b>EUCONV</b>
Module Input			<p><b>[Explanation]</b> The module converts the unit of IN1 from the unit of P1 to the unit of P2.</p> 	
IN1	<input type="radio"/>	Input 1		
IN2				
IN3				
IN4				
IN5				
IN6				
IN7				
IN8				
Module Parameter				
P1	<input type="radio"/>	Data type of module input		
P2	<input type="radio"/>	Data type of module output		
P3				
P4				
Module Output				
OUT	<input type="radio"/>	EU range converted output		
Work Area				
Limitation on Usage				
<p><b>[TIP]</b> P1: Data type of module input = 0: AIN1 (SH1, SL1, DP1) = 1: AIN2 (SH2, SL2, DP2) = 2: AIN3 (SH3, SL3, DP3) P2: Data type of module output = 0: PV1 (P.RH1, P.RL1, P.DP1) = 1: PV2 (P.RH2, P.RL2, P.DP2)</p> <p><b>[TIP]</b> Setup parameters include SH1 to 3, SL1 to 3, DP1 to 3, P.RH1 and 2, P.RL1 and 2, and P.DP1 and 2.</p> <p><b>[Detailed Explanation]</b> In normal application, the analog input (AIN) undergoes a specific type of computational process as necessary, while coupled with the process variable input (PVIN). Assume that AIN1 is coupled with PVIN.1, and each pair of maximum and minimum values for these inputs is set to RH1 and RL1 (or SH1 and SL1 if the input is DC voltage), and P.RH1 and P.RL1. If both of these pairs are set to the same range, the EUCONV module need not be used. If their ranges differ, the EUCONV module is placed between AIN1 and PVIN.1 so that conversion is carried out between the two different ranges in order to match the types of data. For example, assume that RH1 = 1000 °C and RL1 = 0 °C, and P.RH1 = 2000 °C and P.RL1 = 0 °C. A signal input to AIN1 as 1000 °C is regarded as 2000 °C at PVIN.1 if the EUCONV module is absent, resulting in incorrect processing. If the EUCONV module is set in place, conversion is carried out so the signal is regarded as 1000 °C at PVIN.1. To understand this more clearly, the process is explained using specific values of internal data. For AIN1 or PVIN.1, the module internally has a pair of upper and lower limits for the given range, and of which are set in whole numbers, e.g., (30000, 0). In the example discussed above, the data value of 1000 °C, which is the upper limit of AIN1's span, is handled as 30000 internally. In order for this value to be regarded as 1000 °C when AIN1 is coupled with PVIN.1, it must be converted to 15000. (Since the value "30000" is regarded as 2000 °C at PVIN.1, the value "15000" is equivalent to 1000 °C.) This process is carried out by the EUCONV module in actual applications.</p> 				
<p>⊙: Signed 4-byte data; ○: Signed 2-byte data; ●: Flag of 0 or 1; ×: No output</p>				

Module No.	<b>42</b>		Category	Special Operation
Module Name	Switching Between Two Inputs		Module Code Name	<b>SELECT2</b>
Module Input			<p><b>[Computational Expression and Explanation]</b>                      The module calculates equations comprising IN1 and/or IN2 according to the given switching method, and then outputs the result.</p> <p>P1 = 0 (zone switching):                      If <math>IN1 \leq P3</math>, then <math>OUTn = IN1</math>,                      If <math>P2 \leq IN1</math>, then <math>OUTn = IN2</math>,                      If <math>P3 &lt; IN1 &lt; P2</math>, then <math>OUTn = (1 - x) \times IN1 + (x) \times IN2</math>,                      where, <math>x = (IN1 - P3) / (P2 - P3)</math>.</p> <p>P1 = 1 (switching based on upper limit):                      If <math>IN1 \geq P2</math>, then <math>OUTn = IN2</math>,                      If <math>IN1 &lt; P2 - 150</math>, then <math>OUT = IN1</math>.                      The module turns on the internal tracking flag when the input is switched.</p> <p>P1 = 2 (switching based on flag):                      If <math>P4 = 0</math>, then <math>OUT = IN1</math>,                      If <math>P4 = 1</math>, then <math>OUT = IN2</math>.                      The module turns on the internal tracking flag when the input is switched.</p>	
IN1	<input type="radio"/>	Input 1		
IN2	<input type="radio"/>	Input 2		
IN3				
IN4				
IN5				
IN6				
IN7				
IN8				
Module Parameter				
P1	<input type="radio"/>	Switching method		
P2	<input type="radio"/>	Upper limit for switching		
P3	<input type="radio"/>	Lower limit for switching		
P4	<input checked="" type="radio"/>	Switching flag		
Module Output				
OUT	<input type="radio"/>	Output based on switched inputs		
Work Area	2			
Limitation on Usage				
<p><b>[NOTE]</b>                      The internal tracking flag is referenced by the control and computation unit so that the output does not bump during switching. If tracking is performed on PV1 however, the output bumps when a switch is made using an external contact.</p> <p><b>[TIP]</b>                      The SELECT2 module is used when the controller mode (UP mode) is loop control with PV switching (UP mode 6) or loop control with PV switching and two universal inputs (UP mode 14).</p>				
<p>⊙: Signed 4-byte data; ○: Signed 2-byte data; ●: Flag of 0 or 1; ×: No output</p>				



Module No.	<b>42</b>	Category	Special Operation
Module Name	Switching Between Two Inputs	Module Code Name	<b>SELECT2</b>

• Zone Switching

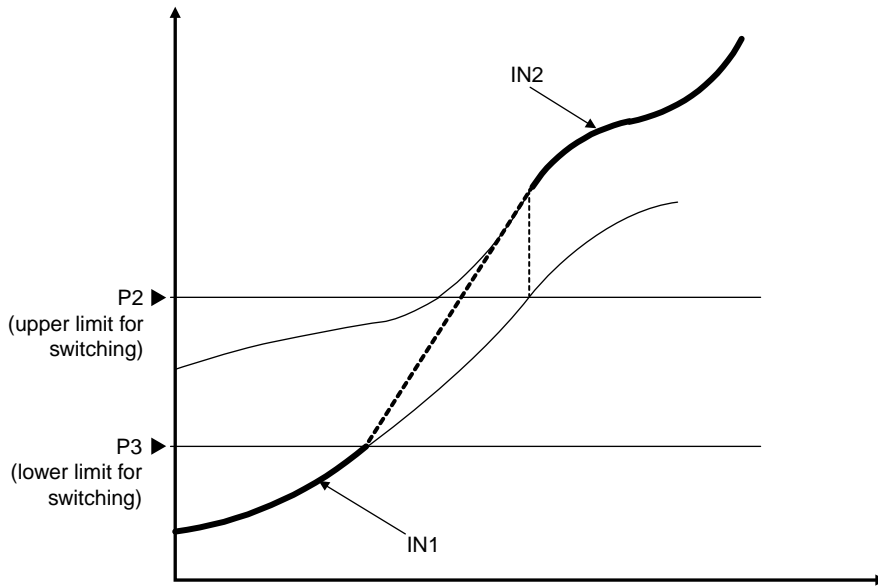

• Switching Based on Upper Limit

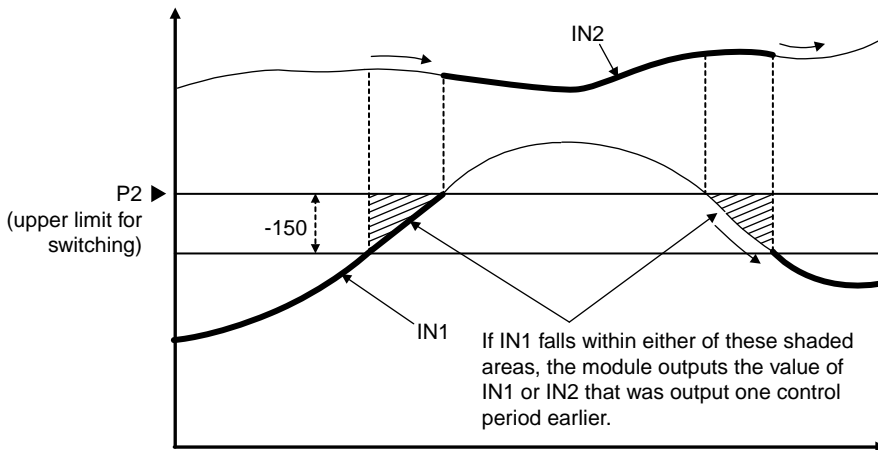

• Switching Based on Flag

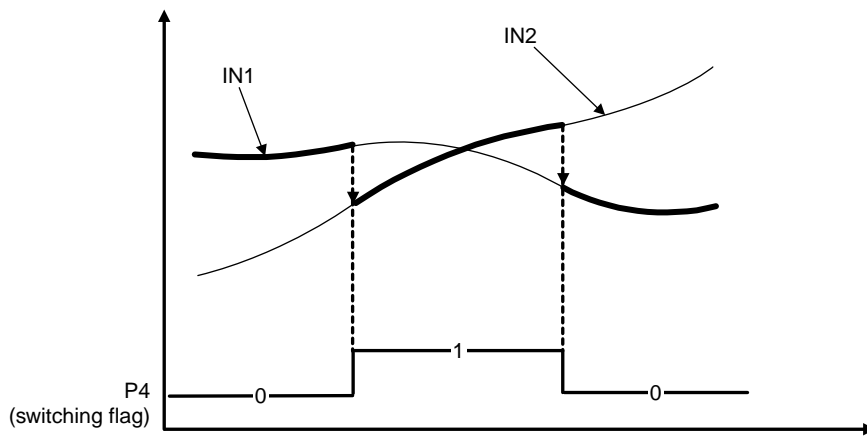

⊙: Signed 4-byte data; ○: Signed 2-byte data; ●: Flag of 0 or 1; ×: No output

Module No.	<b>43</b>		Category	Special Operation
Module Name	Temperature and Humidity Calculation		Module Code Name	<b>TMPHUM</b>
Module Input			<p><b>[Computational Expression]</b>  <math>Relative\ humidity = 1/ed \times (ew - 0.5 \times P \times (Td - Tw) / 755)</math>                      where,                      ed = saturation vapor pressure (hPa) at dry-bulb temperature, which is calculated from Td                      ew = saturation vapor pressure (hPa) at wet-bulb temperature, which is calculated from Tw                      Td = dry-bulb temperature (°C)                      Tw = wet-bulb temperature (°C)                      P = atmospheric pressure (1013.25 hPa)</p>	
IN1	<input type="radio"/>	Dry-bulb temperature		
IN2	<input type="radio"/>	Wet-bulb temperature		
IN3				
IN4				
IN5				
IN6				
IN7				
IN8				
Module Parameter				
P1	<input type="radio"/>	Data type of IN1		
P2	<input type="radio"/>	Data type of IN2		
P3	<input type="radio"/>	Data type of OUT		
P4				
Module Output				
OUT	<input type="radio"/>	Calculated relative humidity		
Work Area				
Limitation on Usage		1		
<p><b>[Explanation]</b>                      The module determines the relative humidity from the dry- and wet-bulb temperatures and outputs it.                      Data range of OUT: 0.0 to 100.0 %RH                      The modules adjust the range to that specified by the type of output data (P3).                      Example: If the range specified is 0.0 to 100.0, the range remains as is.                      If the range specified is 0.0 to 200.0, it is adjusted to the range from 0.0 to 100.0.                      Computation accuracy: ±0.31 %RH                      Computing is possible only if Td and Tw are in the range from 0 °C to 100 °C and Td &gt; Tw.                      If Td or Tw &lt; 0 °C or if the resulting value of computation is negative, the relative humidity is 0 %RH.                      If Td or Tw &gt; 100 °C and Td &lt; Tw, the relative humidity is 100 %RH.                      The saturation vapor pressure complies with the JIS Z8806-1981 standard.</p> <p><b>[TIP]</b>                      P1: data type of IN1                          = 0: AIN1                          = 1: AIN2                          = 2: AIN3                      P2: data type of IN2                          = 0: AIN1                          = 1: AIN2                          = 2: AIN3                      P3: data type of OUT                          = 0: PV1                          = 1: PV2</p>				
<p>⊙: Signed 4-byte data; ○: Signed 2-byte data; ●: Flag of 0 or 1; ×: No output</p>				

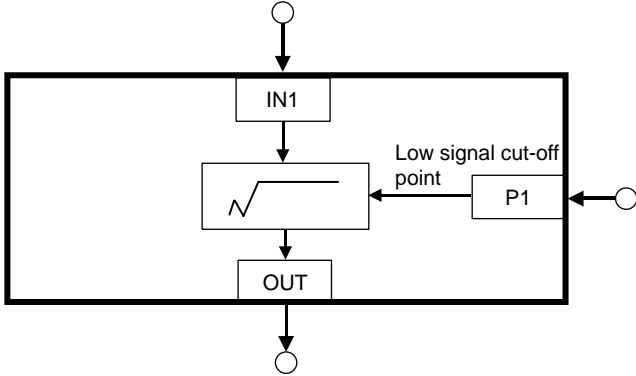
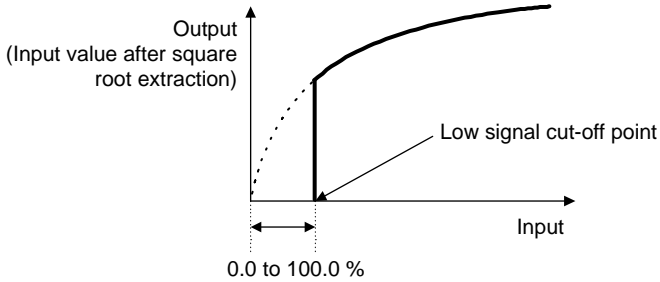
Module No.	<b>44</b>		Category	Special Operation
Module Name	Square Root Extraction		Module Code Name	<b>SQR</b>
Module Input			<p><b>[Computational Expression]</b>  <math>OUT = \sqrt{IN1}</math>, where a low signal cut-off based on P1 is applied</p>  <p><b>[Explanation]</b>                  The module replaces a value on the 0 to 30000 scale with a value on the 0 to 1 scale in order to extract the square root of that value. It then converts the result back to a value on the 0 to 30000 scale for output.                  Example: The square root of 30000 results in the value 30000.                  The square root of 15000 results in the value 21213.</p> <p>If <math>IN1 &lt; P1</math>, then <math>OUT = 0</math> (low signal cut-off)                  If <math>IN1 \leq 0</math>, then <math>OUT = 0</math></p>  <p><b>[TIP]</b>                  Use the SQR2 module (Module No. 73) when the output below the low signal cut-off point needs to be linearized.</p>	
IN1	<input type="radio"/>	Input 1		
IN2				
IN3				
IN4				
IN5				
IN6				
IN7				
IN8				
Module Parameter				
P1	<input type="radio"/>	Low signal cut-off point		
P2				
P3				
P4				
Module Output				
OUT	<input type="radio"/>	Result of square root extraction		
Work Area				
Limitation on Usage				

⊙: Signed 4-byte data; ○: Signed 2-byte data; ●: Flag of 0 or 1; ×: No output

Module No.	<b>45</b>		Category	Special Operation
Module Name	Detection of Change		Module Code Name	<b>CHGDET</b>
Module Input			<b>[Computational Expression and Explanation]</b>	
IN1	●	Input 1	If IN1 changes (from 0 to 1 or vice versa), OUT = 1 for one control period.	
IN2				
IN3				
IN4				
IN5				
IN6				
IN7				
IN8				
Module Parameter				
P1				
P2				
P3				
P4				
Module Output				
OUT	●	Result of detection		
Work Area	1			
Limitation on Usage				
			<p>This module is used to generate timing signals for processing.</p>	
<p>◎: Signed 4-byte data; ○: Signed 2-byte data; ●: Flag of 0 or 1; ×: No output</p>				

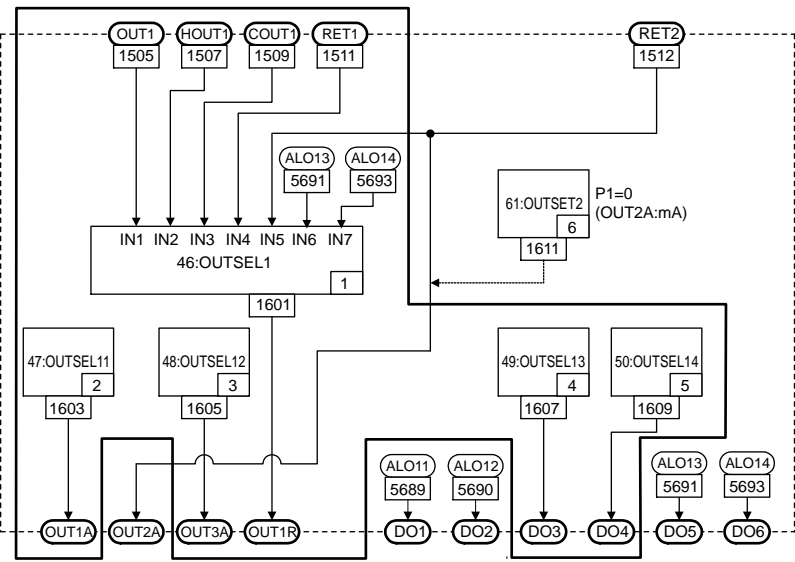
Module No.	<b>46</b>		Category	Special Operation
Module Name	Loop 1 Output Selection 1		Module Code Name	<b>OUTSEL1</b>
Module Input			<p><b>[Explanation]</b>                      The module allocates the loop 1 control output.                      Always use this module together with the OUTSEL11, 12, 13 and 14 modules.                      The figure below shows a diagram of the output block of single-loop control (UP mode 1).</p> <p>OUT : This module uses either an on-off output or a time proportional relay contact output.</p> <p><b>[TIP]</b>                      The module allocates the manipulated output, as shown below, according to information in the OT1 setup parameter (control output 1 selection). For cascade-based control, however, OT2 is used.</p> <p><b>[See Also]</b>                      Control output 1 selection (OT1) and control output 2 selection (OT2) in UP750 User s Manual for Single loop Control (IM 05E01B02-01E to -07E)</p> <p>OUT1R : A relay contact control output is provided by the OUTSEL1 module.                      OUT1A : A control output or retransmission output 2 is provided by the OUTSEL11 module.  <b>[See Also]</b>                      Loop 1 Output Selection 11 —OUTSEL11 Module (Module No. 47).</p> <p>OUT3A : Either a cooling-side control output or retransmission output 1 (RET1) is provided by the OUTSEL12 module.  <b>[See Also]</b>                      Loop 1 Output Selection 12 —OUTSEL12 Module (Module No. 48).</p> <p>DO3 : Either a relay contact cooling-side control output or alarm 3 output (AL3) is provided by the OUTSEL13 module.  <b>[See Also]</b>                      Loop 1 Output Selection 13 —OUTSEL13 Module (Module No. 49).</p> <p>DO4 : Either a transistor cooling-side control output or alarm 4 output (AL4) is provided by the OUTSEL14 module.  <b>[See Also]</b>                      Loop 1 Output Selection 14 —OUTSEL14 Module (Module No. 50).</p>	
IN1	<input type="radio"/>	Input 1 (OUT1)		
IN2	<input type="radio"/>	Input 2 (HOUT1)		
IN3	<input type="radio"/>	Input 3 (COUT1)		
IN4	<input type="radio"/>	Input 4 (RET1)		
IN5	<input type="radio"/>	Input 5 (RET2)		
IN6	<input type="radio"/>	Input 6 (ALO13)		
IN7	<input type="radio"/>	Input 7 (ALO14)		
IN8				
Module Parameter				
P1				
P2				
P3				
P4				
Module Output				
OUT	<input type="radio"/>	OUT1R		
Work Area				
Limitation on Usage	1			
 <p><b>NOTE</b>                      It is recommended that the UT750's built-in output blocks of the UP mode be used as they are.</p>				
			<p><b>[Output block]</b></p>  <p>Depending on the setting of the OT1 setup parameter, the outputs of the OUTSEL1, OUTSEL11, OUTSEL12, OUTSEL13 and OUTSEL14 modules are connected to the OUT1R, OUT1A, OUT3A, DO3 and DO4 terminals.</p>	
<p>⊙ : Signed 4-byte data; ○ : Signed 2-byte data; ● : Flag of 0 or 1; × : No output</p>				

Module No.	<b>47</b>		Category	Special Operation
Module Name	Loop 1 Output Selection 11		Module Code Name	<b>OUTSEL11</b>
Module Input			<p><b>[Explanation]</b>                      The module provides the output allocated by the OUTSEL1 module for the OUT1A terminal.                      Always use this module together with the OUTSEL1 module.</p> <p>OUT : This module uses either current output or voltage pulse output.</p> <p> <b>NOTE</b>                      It is recommended that the UP750's built-in output blocks of the UT mode be used as they are.</p>	
IN1				
IN2				
IN3				
IN4				
IN5				
IN6				
IN7				
IN8				
Module Parameter				
P1				
P2				
P3				
P4				
Module Output				
OUT	<input type="radio"/>	Output (OUT1A)		
Work Area				
Limitation on Usage	1			
◎: Signed 4-byte data;   ○: Signed 2-byte data;   ●: Flag of 0 or 1;   ×: No output				

040351E.EPS

Module No.	<b>48</b>		Category	Special Operation
Module Name	Loop 1 Output Selection 12		Module Code Name	<b>OUTSEL12</b>
Module Input			<p><b>[Explanation]</b>                      The module provides the output allocated by the OUTSEL1 module for the OUT3A terminal.                      Always use this module together with the OUTSEL1 module.</p> <p>OUT : This module uses either current output or voltage pulse output.</p> <p> <b>NOTE</b>                      It is recommended that the UP750's built-in output blocks of the UT mode be used as they are.</p>	
IN1				
IN2				
IN3				
IN4				
IN5				
IN6				
IN7				
IN8				
Module Parameter				
P1				
P2				
P3				
P4				
Module Output				
OUT	<input type="radio"/>	Output (OUT3A)		
Work Area				
Limitation on Usage	1			
◎: Signed 4-byte data;   ○: Signed 2-byte data;   ●: Flag of 0 or 1;   ×: No output				

040352E.EPS

Module No.	<b>49</b>		Category	Special Operation
Module Name	Loop 1 Output Selection 13		Module Code Name	<b>OUTSEL13</b>
Module Input			<p><b>[Explanation]</b>                      The module provides the output allocated by the OUTSEL1 module for the DO3 terminal.                      Always use this module together with the OUTSEL1 module.</p> <p>OUT : This module uses either an on-off output or a time proportional relay output.</p> <p> <b>NOTE</b>                      It is recommended that the UP750's built-in output blocks of the UT mode be used as they are.</p>	
IN1				
IN2				
IN3				
IN4				
IN5				
IN6				
IN7				
IN8				
Module Parameter				
P1				
P2				
P3				
P4				
Module Output				
OUT	<input type="radio"/>	Output (DO3)		
Work Area				
Limitation on Usage	1			
◎: Signed 4-byte data;   ○: Signed 2-byte data;   ●: Flag of 0 or 1;   ×: No output				

040353E.EPS

Module No.	<b>50</b>		Category	Special Operation
Module Name	Loop 1 Output Selection 14		Module Code Name	<b>OUTSEL14</b>
Module Input			<p><b>[Explanation]</b>                      The module provides the output allocated by the OUTSEL1 module for the DO4 terminal.                      Always use this module together with the OUTSEL1 module.</p> <p>OUT : This module uses either an on-off output or a time proportional relay output.</p> <p> <b>NOTE</b>                      It is recommended that the UP750's built-in output blocks of the UT mode be used as they are.</p>	
IN1				
IN2				
IN3				
IN4				
IN5				
IN6				
IN7				
IN8				
Module Parameter				
P1				
P2				
P3				
P4				
Module Output				
OUT	<input type="radio"/>	Output (DO4)		
Work Area				
Limitation on Usage	1			
◎: Signed 4-byte data;   ○: Signed 2-byte data;   ●: Flag of 0 or 1;   ×: No output				

040354E.EPS

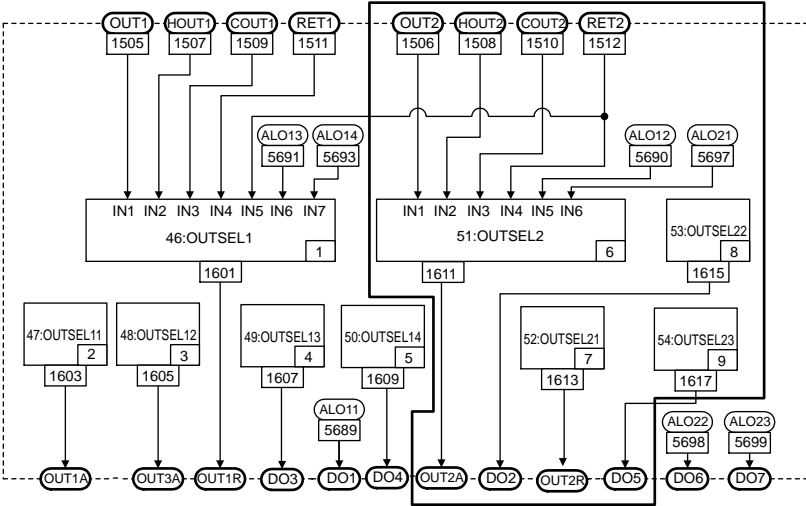
Module No.	<b>51</b>		Category	Special Operation
Module Name	Loop 2 Output Selection 2		Module Code Name	<b>OUTSEL2</b>
Module Input			<p><b>[Explanation]</b> The module allocates the loop 2 manipulated output. Always use this module together with the OUTSEL21, 22 and 23 modules.</p> <p><b>[NOTE]</b> This module can be used only if the controller type is set for dual-loop type.</p> <p>The figure below shows a diagram of the output block of dual-loop control (UP mode 11). OUT : This module uses either an on-off output or time proportional relay contact output.</p> <p><b>[TIP]</b> The module allocates the manipulated output, as shown below, according to information in the OT2 setup parameter (control output 2 selection).</p> <p><b>[See Also]</b> Control output 2 selection (OT2) in UP750 User s Manual for Single-loop Control (IM 05E01B02-01E to -07E)</p> <p>OUT2R : A relay contact control output is provided by the OUTSEL2 module. OUT2A : Either a control output or retransmission output 2 (RET2) is provided by the OUTSEL21 module. <b>[See Also]</b> Loop 2 Output Selection 21 —OUTSEL21 Module (Module No. 52)</p> <p>DO2 : Either a relay contact cooling-side control output or Loop 1 alarm 2 output (1.AL2) is provided by the OUTSEL22 module. <b>[See Also]</b> Loop 2 Output Selection 22 —OUTSEL22 Module (Module No. 53)</p> <p>DO5 : Either a transistor cooling-side output or Loop 2 alarm 1 output (2.AL1) is provided by the OUTSEL23 module. <b>[See Also]</b> Loop 2 Output Selection 23 —OUTSEL23 Module (Module No. 54)</p>	
IN1	<input type="radio"/>	Input 1 (OUT2)		
IN2	<input type="radio"/>	Input 2 (HOUT2)		
IN3	<input type="radio"/>	Input 3 (COUT2)		
IN4	<input type="radio"/>	Input 4 (RET2)		
IN5	<input type="radio"/>	Input 5 (ALO12)		
IN6	<input type="radio"/>	Input 6 (ALO21)		
IN7				
Module Parameter				
P1				
P2				
P3				
P4				
Module Output				
OUT	<input type="radio"/>	Output (OUT2R)		
Work Area				
Limitation on Usage		1		
 <p><b>NOTE</b> It is recommended that the UT750's built in output blocks of the UP mode be used as they are.</p>				
			<p><b>[Output block]</b></p>  <p>Depending on the value of OT2 setup parameter, the outputs of OUTSEL2, OUTSEL21, OUTSEL22, OUTSEL23 modules are connected to the OUT2R, OUT2A, DO2, and DO5 terminals.</p>	
<p>⊙ : Signed 4-byte data; ○ : Signed 2-byte data; ● : Flag of 0 or 1; × : No output</p>				



Module No.	<b>52</b>		Category	Special Operation
Module Name	Loop 2 Output Selection 21		Module Code Name	<b>OUTSEL21</b>
Module Input			<p><b>[Explanation]</b>                      The module provides the output allocated by the OUTSEL2 module for the OUT2A terminal.                      Always use this module together with the OUTSEL2 module.</p> <p>OUT : This module uses either current output or voltage pulse output.</p> <p><b>[NOTE]</b>                      This module can be used only if the controller type is set for dual-loop type.</p> <p> <b>NOTE</b>                      It is recommended that the UT750's built-in output blocks of the UP mode be used as they are.</p>	
IN1				
IN2				
IN3				
IN4				
IN5				
IN6				
IN7				
IN8				
Module Parameter				
P1				
P2				
P3				
P4				
Module Output				
OUT	<input type="radio"/>	Output (OUT2A)		
Work Area				
Limitation on Usage		1		
◎: Signed 4-byte data;   ○ : Signed 2-byte data;   ● : Flag of 0 or 1;   ×: No output				

040356E.EPS

Module No.	<b>53</b>		Category	Special Operation
Module Name	Loop 2 Output Selection 22		Module Code Name	<b>OUTSEL22</b>
Module Input			<p><b>[Explanation]</b>                      The module provides the output allocated by the OUTSEL2 module for the DO2 terminal.                      Always use this module together with the OUTSEL2 module.</p> <p>OUT : This module uses either current output or voltage pulse output.</p> <p><b>[NOTE]</b>                      This module can be used only if the controller type is set for dual-loop type.</p> <p> <b>NOTE</b>                      It is recommended that the UT750's built-in output blocks of the UP mode be used as they are.</p>	
IN1				
IN2				
IN3				
IN4				
IN5				
IN6				
IN7				
IN8				
Module Parameter				
P1				
P2				
P3				
P4				
Module Output				
OUT	<input type="radio"/>	Output (DO2)		
Work Area				
Limitation on Usage		1		
◎: Signed 4-byte data;   ○ : Signed 2-byte data;   ● : Flag of 0 or 1;   ×: No output				

040357E.EPS

Module No.	<b>54</b>		Category	Special Operation
Module Name	Loop 2 Output Selection 23		Module Code Name	<b>OUTSEL23</b>
Module Input			<p><b>[Explanation]</b>                      The module provides the output allocated by the OUTSEL2 module for the DO5 terminal.                      Always use this module together with the OUTSEL2 module.</p> <p>OUT : This module uses either current output or voltage pulse output.</p> <p><b>[NOTE]</b>                      This module can be used only if the controller type is set for dual-loop type.</p> <p> <b>NOTE</b>                      It is recommended that the UT750's built-in output blocks of the UP mode be used as they are.</p>	
IN1				
IN2				
IN3				
IN4				
IN5				
IN6				
IN7				
IN8				
Module Parameter				
P1				
P2				
P3				
P4				
Module Output				
OUT	<input type="radio"/>	Output (DO5)		
Work Area				
Limitation on Usage	1			

◎: Signed 4-byte data; ○: Signed 2-byte data; ●: Flag of 0 or 1; ×: No output

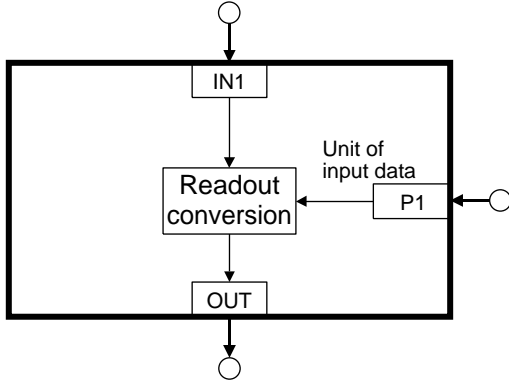
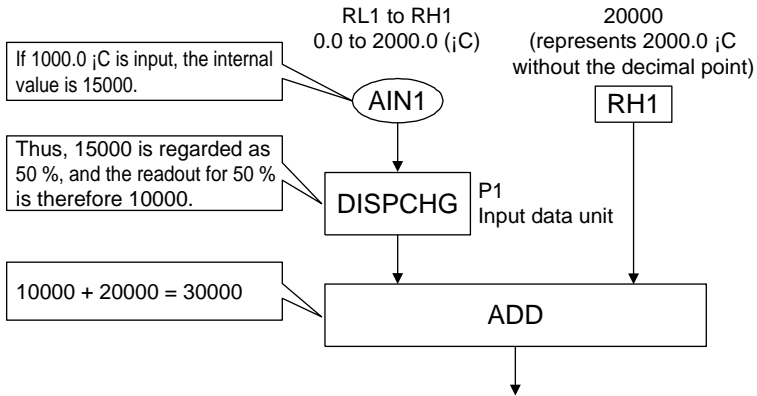
Module No.	<b>55</b>		Category	Special Function																
Module Name	Display Data Unit Conversion		Module Code Name	<b>DISPCHG</b>																
Module Input			<p><b>[Computational Expression]</b>                  OUT = an absolute value without a decimal point is obtained by converting the IN1 reading</p> 																	
IN1	<input type="radio"/>	Input 1																		
IN2																				
IN3																				
IN4																				
IN5																				
IN6																				
IN7																				
IN8																				
Module Parameter			<p><b>[Explanation]</b>                  The module converts the IN1 reading into the unit specified by P1 and into a non-decimal data format.</p> <p><b>[TIP]</b>                  P1: unit of input data (0 to 15)</p> <table border="0"> <tr> <td>0 : %</td> <td>8 : EU (AIN2)</td> </tr> <tr> <td>1 : ABS0</td> <td>9 : EUS (AIN2)</td> </tr> <tr> <td>2 : ABS1</td> <td>10 : EU (AIN3)</td> </tr> <tr> <td>3 : ABS2</td> <td>11 : EUS (AIN3)</td> </tr> <tr> <td>4 : ABS3</td> <td>12 : EU (PV1)</td> </tr> <tr> <td>5 : ABS4</td> <td>13 : EUS (PV1)</td> </tr> <tr> <td>6 : EU (AIN1)</td> <td>14 : EU (PV2)</td> </tr> <tr> <td>7 : EUS (AIN1)</td> <td>15 : EUS (PV2)</td> </tr> </table> <p><b>[Example of Use]</b>                  The internal value of AIN1 is converted by the DISPCHG module to a readout and then added to RH1. Input data unit of DISPCHG module is assumed to be ABS0.                  RH1 : Maximum value of analog input 1 range (setup parameter)</p> 		0 : %	8 : EU (AIN2)	1 : ABS0	9 : EUS (AIN2)	2 : ABS1	10 : EU (AIN3)	3 : ABS2	11 : EUS (AIN3)	4 : ABS3	12 : EU (PV1)	5 : ABS4	13 : EUS (PV1)	6 : EU (AIN1)	14 : EU (PV2)	7 : EUS (AIN1)	15 : EUS (PV2)
0 : %	8 : EU (AIN2)																			
1 : ABS0	9 : EUS (AIN2)																			
2 : ABS1	10 : EU (AIN3)																			
3 : ABS2	11 : EUS (AIN3)																			
4 : ABS3	12 : EU (PV1)																			
5 : ABS4	13 : EUS (PV1)																			
6 : EU (AIN1)	14 : EU (PV2)																			
7 : EUS (AIN1)	15 : EUS (PV2)																			
P1	<input type="radio"/>	Unit of input data (0 to 15)																		
P2																				
P3																				
P4																				
Module Output			<p><b>[Example of Use]</b>                  The internal value of AIN1 is converted by the DISPCHG module to a readout and then added to RH1. Input data unit of DISPCHG module is assumed to be ABS0.                  RH1 : Maximum value of analog input 1 range (setup parameter)</p>																	
OUT	<input type="radio"/>	Display data conversion output																		
Work Area																				
Limitation on Usage																				

⊙: Signed 4-byte data; ○: Signed 2-byte data; ●: Flag of 0 or 1; ×: No output

Module No.	<b>56</b>		Category	Special Function
Module Name	Parameter Setting		Module Code Name	<b>PARASET</b>
Module Input			<p><b>[Explanation]</b>                  If P2 changes from 0 to 1, the module writes the value of IN1 into the register specified by P1.                  Data of IN1 = non-decimal reading                  Writable registers: D101 to 1200 (excluding those not yet mapped)</p>	
IN1	<input type="radio"/>	Data to write		
IN2				
IN3				
IN4				
IN5				
IN6				
IN7				
IN8				
Module Parameter				
P1	<input type="radio"/>	Number of register to be written in		
P2	<input checked="" type="radio"/>	Write flag		
P3				
P4				
Module Output				
OUT	<input checked="" type="checkbox"/>			
Work Area		4		
Limitation on Usage				
			<p><b>[TIP]</b>                  P1: the number of the register to which data is written (constant value: 101 to 1200)                  P2: write flag (data is written if P2 = 1)</p> <p> <b>NOTE</b>                  Set the write register number in P1 in immediate data.</p> <p><b>[See Also]</b>                  LL200 PC-Based Custom Computation Building Tool user's manual (IM 05G01B22-01E), for an example using PARASET.</p>	

◎: Signed 4-byte data; ○: Signed 2-byte data; ●: Flag of 0 or 1; ×: No output

Module No.		<b>57</b>		Category	Special Function
Module Name		Data Display 1		Module Code Name	<b>DISP1</b>
Module Input				<p><b>[Explanation]</b>                      The module indicates the value of IN1 on the DISP display.                      The unit of the value indicated complies with the unit of data specified in P1.</p> <p><b>[TIP]</b>                      P1: unit of input data (0 to 15)                      0 : %                      8 : EU (AIN2)                      1 : ABS0                  9 : EUS (AIN2)                      2 : ABS1                  10 : EU (AIN3)                      3 : ABS2                  11 : EUS (AIN3)                      4 : ABS3                  12 : EU (PV1)                      5 : ABS4                  13 : EUS (PV1)                      6 : EU (AIN1)            14 : EU (PV2)                      7 : EUS (AIN1)         15 : EUS (PV2)</p>	
IN1	<input type="radio"/>	Data to be displayed			
IN2					
IN3					
IN4					
IN5					
IN6					
IN7					
IN8					
Module Parameter					
P1	<input type="radio"/>	Unit of input data (0 to 15)			
P2					
P3					
Module Output				<p><b>Example of Setup Procedure</b></p> <p>[1] Register the DISP1 module (No. 57) with the input block or output block, and then configure the module input (IN1) and parameter (P1).</p> <p>[2] In the Operating Display Selection dialog box, select "DISP Display" or display No. 25.</p> <p>If you wish to indicate a character string other than "DISP" in the DISP Display, do the following.</p> <ul style="list-style-type: none"> <li>In the Operating Display Selection dialog box, click the "Setting of Display Characters" button and enter a character string that includes no more than five alphanumeric characters.</li> </ul>	
OUT	×				
Work Area					
Limitation on Usage		1			

⊙: Signed 4-byte data; ○: Signed 2-byte data; ●: Flag of 0 or 1; ×: No output

Module No.	<b>58</b>		Category	Special Function
Module Name	Data Display 2		Module Code Name	<b>DISP2</b>
Module Input			<p><b>[Explanation]</b>                  The module indicates the value of IN1 on the DISP display.                  The unit of the value indicated complies with the unit of data specified in P1.</p> <p><b>[TIP]</b>                  P1: unit of input data (0 to 15)                  0 : %                      8 : EU (AIN2)                  1 : ABS0                  9 : EUS (AIN2)                  2 : ABS1                  10 : EU (AIN3)                  3 : ABS2                  11 : EUS (AIN3)                  4 : ABS3                  12 : EU (PV1)                  5 : ABS4                  13 : EUS (PV1)                  6 : EU (AIN1)            14 : EU (PV2)                  7 : EUS (AIN1)         15 : EUS (PV2)</p> <p>Example of Setup Procedure: See the example in "Data Display 1."</p>	
IN1	<input type="radio"/>	Data to be displayed		
IN2				
IN3				
IN4				
IN5				
IN6				
IN7				
IN8				
Module Parameter				
P1	<input type="radio"/>	Unit of input data (0 to 15)		
P2				
P3				
P4				
Module Output				
OUT	<input type="checkbox"/>			
Work Area				
Limitation on Usage		1		

◎: Signed 4-byte data; ○: Signed 2-byte data; ●: Flag of 0 or 1; ×: No output

Module No.	<b>59</b>		Category	Special Function
Module Name	Special DO Output		Module Code Name	<b>EXPRO</b>
Module Input			<p><b>[Explanation]</b> The module outputs a 16-bit pattern of IN1 data to the expanded contact outputs.</p> <p>Bits 0 through 7 of IN1 are output to OUTPUT51 through OUPUT58 of the contact I/O expansion module 1; bits 8 through 15 of IN1 are output to OUTPUT51 through OUPUT58 of the contact I/O expansion module 2.</p> <p>The module outputs the bits from bit 0 by the number specified with P1.</p> <p><b>[Example]</b> When P1 = 5, bit 0 through bit 4 are output to the OUTPUT51 through OUPUT55 of the contact I/O expansion module 1.</p> <p><b>[NOTE]</b> The expanded contact outputs driven by this module take priority over the event settings configured using setup parameters.</p>	
IN1	<input type="radio"/>	Bit pattern to output		
IN2				
IN3				
IN4				
IN5				
IN6				
IN7				
IN8				
Module Parameter				
P1	<input type="radio"/>	Number of output bits (1 to 16)		
P2				
P3				
P4				
Module Output				
OUT	<input type="checkbox"/>			
Work Area				
Limitation on Usage				

◎: Signed 4-byte data; ○: Signed 2-byte data; ●: Flag of 0 or 1; ×: No output

Module No.	<b>60</b>		Category	Special Function
Module Name	Output 1 Terminal Configuration		Module Code Name	<b>OUTSET1</b>
Module Input			<p><b>[Explanation]</b> The module selects the function of the OUT1A terminal.</p> <p>P1: OUT1A's output type specification If P1 = 0, the output type is current output (mA). If P1 = 1, the output type is voltage pulse output.</p> <p><b>[NOTE]</b> This module can be used only when the OUTSEL1 module is not used (i.e., it cannot be used together with the OUTSEL1 module).</p>	
IN1				
IN2				
IN3				
IN4				
IN5				
IN6				
IN7				
IN8				
Module Parameter				
P1	<input checked="" type="radio"/>	OUT1A's output type specification		
P2				
P3				
P4				
Module Output				
OUT	<input checked="" type="radio"/>			
Work Area				
Limitation on Usage		1		
◎: Signed 4-byte data;   ○: Signed 2-byte data;   ●: Flag of 0 or 1;   ×: No output				

040364E.EPS

Module No.	<b>61</b>		Category	Special Function
Module Name	Output 2 Terminal Configuration		Module Code Name	<b>OUTSET2</b>
Module Input			<p><b>[Explanation]</b> The module selects the function of the OUT2A terminal.</p> <p>P1: OUT2A's output type specification If P1 = 0, the output type is current output (mA). If P1 = 1, the output type is voltage pulse output.</p> <p><b>[NOTE]</b> This module can be used only when the OUTSEL2 module is not used (i.e., it cannot be used together with the OUTSEL1 module).</p>	
IN1				
IN2				
IN3				
IN4				
IN5				
IN6				
IN7				
IN8				
Module Parameter				
P1	<input checked="" type="radio"/>	OUT2A's output type specification		
P2				
P3				
P4				
Module Output				
OUT	<input checked="" type="radio"/>			
Work Area				
Limitation on Usage		1		
◎: Signed 4-byte data;   ○: Signed 2-byte data;   ●: Flag of 0 or 1;   ×: No output				

040365E.EPS



Module No.	<b>62</b>		Category	Special Operation
Module Name	Fluid Temperature Compensation		Module Code Name	<b>TCOMP</b>
Module Input			<p><b>[Computational Expression]</b>  <math>OUT = IN1 \times (P1 + P2) / (IN2 + P2)</math></p>	
IN1	<input type="radio"/>	Flow		
IN2	<input type="radio"/>	Temperature		
IN3				
IN4				
IN5				
IN6				
IN7				
IN8				
Module Parameter				
P1	<input type="radio"/>	Reference temperature for compensation		
P2	<input type="radio"/>	Constant (based on temperature unit)		
P3	<input type="radio"/>	Specified source of measured input temperature		
P4				
Module Output				
OUT	<input type="radio"/>	Fluid temperature compensation		
Work Area				
Limitation on Usage				
			<p><b>[TIP]</b>  P2 = 273 (unit: °C), 459.4 (unit: °F)  P3 = 0 : AIN1  = 1 : AIN2  = 2 : AIN3</p> <p><b>[NOTE]</b>  Value that are actually set are constant values without the decimal point.</p> <p><b>[See Also]</b>  LL200 PC-Based Custom Computation Building Tool user's manual (IM 05G01B22-01E), for an example of setting up fluid temperature compensation.</p>	

⊙: Signed 4-byte data; ○: Signed 2-byte data; ●: Flag of 0 or 1; ×: No output

Module No.	<b>63</b>		Category	Special Operation
Module Name	Fluid Pressure Compensation		Module Code Name	<b>PCOMP</b>
Module Input			<p><b>[Computational Expression]</b>  <math>OUT = IN1 \times (IN2 + P2) / (P1 + P2)</math></p>	
IN1	<input type="radio"/>	Flow		
IN2	<input type="radio"/>	Pressure		
IN3				
IN4				
IN5				
IN6				
IN7				
IN8				
Module Parameter				
P1	<input type="radio"/>	Reference pressure for compensation		
P2	<input type="radio"/>	Constant (based on pressure unit)		
P3	<input type="radio"/>	Specified source of measured input pressure		
P4				
Module Output				
OUT	<input type="radio"/>	Fluid pressure compensation		
Work Area				
Limitation on Usage				
			<p><b>[TIP]</b>  P2 = 1013 (101.3kPa)  P3 = 0 : AIN1  = 1 : AIN2  = 2 : AIN3</p> <p><b>[NOTE]</b>  Values that are actually set are immediate values without the decimal point.</p>	

◎: Signed 4-byte data; ○: Signed 2-byte data; ●: Flag of 0 or 1; ×: No output

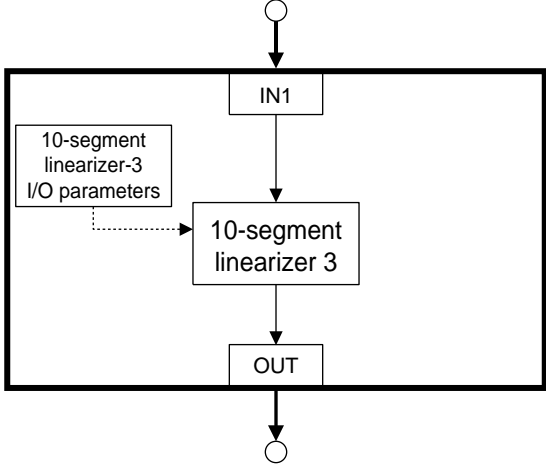
Module No.	<b>64</b>		Category	Special Operation
Module Name	10-segment Linearizer 3 Approximation		Module Code Name	<b>PLINE3</b>
Module Input			<p><b>[Computational Expression]</b>                      if <math>IN1 &lt; A_1</math> then <math>OUT = B_1</math>                      if <math>IN1 &gt; A_{11}</math> then <math>OUT = B_{11}</math>                      if <math>A_n \leq IN1 \leq A_{n+1}</math> then <math>OUT = B_n + (B_{n+1} - B_n) \times (IN1 - A_n) / (A_{n+1} - A_n)</math>                      where, <math>n = 1</math> to <math>10</math></p> <p><math>A_n</math>: Value of 10-segment linearizer 3 input parameter  <math>B_n</math>: Value of 10-segment linearizer 3 output parameter</p> 	
IN1	<input type="radio"/>	Input of 10-segment linearizer 3 approximation		
IN2				
IN3				
IN4				
IN5				
IN6				
IN7				
IN8				
Module Parameter				
P1				
P2				
P3				
P4				
Module Output				
OUT	<input type="radio"/>	Output of 10-segment linearizer 3 approximation		
Work Area				
Limitation on Usage				
			<p><b>[Explanation]</b>                      The module outputs the value of IN1 obtained by linear approximation based on the table of 10-segment linearizer 3 (PYS3) parameters.</p> <p><b>[NOTE]</b>                      The 10-segment linearizer 3 (PYS3) parameters can only be used with the LL200 PC-Based Custom Computation Building Tool.</p> <p><b>[See Also]</b>                      Figure of 10-segment linear approximation in "10-segment Linearizer 1"—PLINE1 Module (Module No. 33)</p>	

⊙: Signed 4-byte data; ○: Signed 2-byte data; ●: Flag of 0 or 1; ×: No output

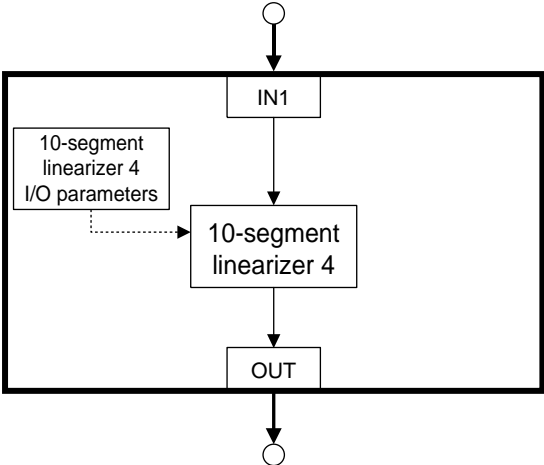
Module No.	<b>65</b>		Category	Special Operation
Module Name	10-segment Linearizer 4 Approximation		Module Code Name	<b>PLINE4</b>
Module Input			<p><b>[Computational Expression]</b>                      if <math>IN1 &lt; A_1</math> then <math>OUT = B_1</math>                      if <math>IN1 &gt; A_{11}</math> then <math>OUT = B_{11}</math>                      if <math>A_n \leq IN1 \leq A_{n+1}</math> then <math>OUT = B_n + (B_{n+1} - B_n) \times (IN1 - A_n) / (A_{n+1} - A_n)</math>                      where, <math>n = 1</math> to <math>10</math></p> <p><math>A_n</math>: Value of 10-segment linearizer 4 input parameter  <math>B_n</math>: Value of 10-segment linearizer 4 output parameter</p> 	
IN1	<input type="radio"/>	Input of 10-segment linearizer 4 approximation		
IN2				
IN3				
IN4				
IN5				
IN6				
IN7				
IN8				
Module Parameter				
P1				
P2				
P3				
P4				
Module Output				
OUT	<input type="radio"/>	Output of 10-segment linearizer 4 approximation		
Work Area				
Limitation on Usage				
			<p><b>[Explanation]</b>                      The module outputs the value of IN1 obtained by linear approximation based on the table of 10-segment linearizer 4 (PYS4) parameters.</p> <p><b>[NOTE]</b>                      The 10-segment linearizer 4 (PYS4) parameters can only be used with the LL200 PC-Based Custom Computation Building Tool.</p> <p><b>[See Also]</b>                      Figure of 10-segment linear approximation in "10-segment Linearizer 1"—PLINE1 Module (Module No. 33)</p>	

⊙: Signed 4-byte data; ○: Signed 2-byte data; ●: Flag of 0 or 1; ×: No output

Module No.	<b>67</b>		Category	Special Operation
Module Name	Dead Time		Module Code Name	<b>DED</b>
Module Input			<p><b>[Computational Expression]</b>  <math>OUT = IN1 (t - P1)</math></p>	
IN1	<input type="radio"/>	Input 1		
IN2				
IN3				
IN4				
IN5				
IN6				
IN7				
IN8				
Module Parameter			<p><b>[Explanation]</b>                  The module outputs the value of IN1 obtained P1 (seconds) ago.                  If P2 = 1, then OUT = IN1.                  The sampling time is P1/20 seconds.</p>	
P1	<input type="radio"/>	Dead time		
P2	<input checked="" type="radio"/>	Reset		
P3				
P4				
Module Output			<p><b>[TIP]</b>                  P1: dead time (0 to 10000 s)</p> <p><b>[NOTE]</b>                  The value of OUT is reset to 0 upon power failure.</p>	
OUT	<input type="radio"/>	Output of dead time computation		
Work Area	46			
Limitation on Usage				

⊙: Signed 4-byte data; ○: Signed 2-byte data; ●: Flag of 0 or 1; ×: No output

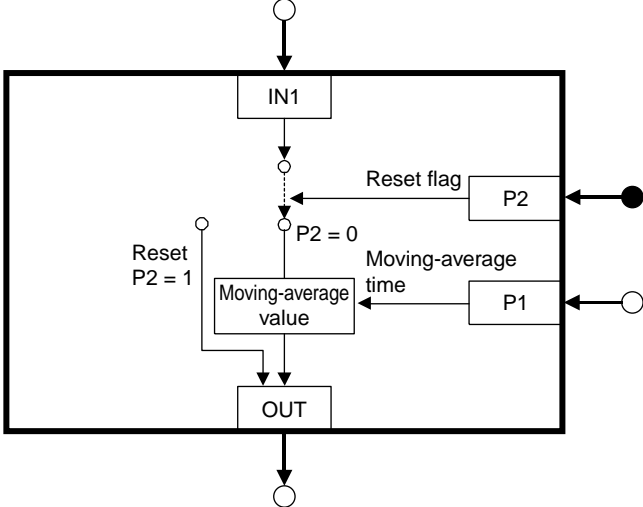
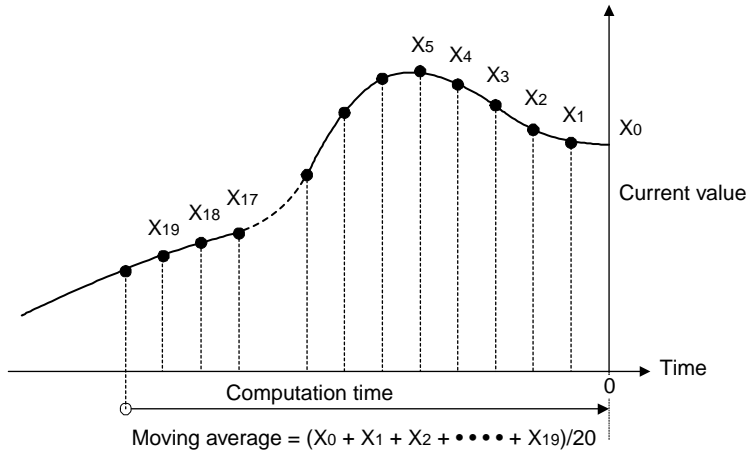
Module No.	<b>68</b>		Category	Special Operation
Module Name	Moving Average		Module Code Name	<b>MAV</b>
Module Input			<p><b>[Computational Expression]</b>  <math>OUT = AVE (IN1 (t - P1) + \dots + IN1 (t) )</math></p> 	
IN1	<input type="radio"/>	Input 1		
IN2				
IN3				
IN4				
IN5				
IN6				
IN7				
IN8				
Module Parameter				
P1	<input type="radio"/>	Moving-average time		
P2	<input checked="" type="radio"/>	Reset flag		
P3				
P4				
Module Output				
OUT	<input type="radio"/>	Moving-average output		
Work Area	46			
Limitation on Usage				
			<p><b>[Explanation]</b>                      The module outputs the average of IN1 over the period of P1.                      If P2 = 1, then OUT = IN1.                      The sampling time is P1/20 seconds.</p> 	
			<p><b>[TIP]</b>                      P1: moving-average time (0 to 10000 s)</p> <p><b>[NOTE]</b>                      The value of OUT is reset to 0 upon power failure.</p>	
<p>⊙: Signed 4-byte data; ○: Signed 2-byte data; ●: Flag of 0 or 1; ×: No output</p>				

Module No.	<b>69</b>		Category	Logical Operation
Module Name	Multi-selector		Module Code Name	<b>MSELECT</b>
Module Input			<p><b>[Computational Expression]</b> The module selects from inputs IN1 to IN8.</p>	
IN1	<input type="radio"/>	Input 1		
IN2	<input type="radio"/>	Input 2		
IN3	<input type="radio"/>	Input 3		
IN4	<input type="radio"/>	Input 4		
IN5	<input type="radio"/>	Input 5		
IN6	<input type="radio"/>	Input 6		
IN7	<input type="radio"/>	Input 7		
IN8	<input type="radio"/>	Input 8		
Module Parameter				
P1	<input type="radio"/>	Selection signal		
P2	<input type="radio"/>	Bias		
P3	<input type="radio"/>	Ratio		
P4				
Module Output				
OUT	<input checked="" type="radio"/>	Selected input value		
Work Area				
Limitation on Usage				
			<p><b>[Explanation]</b> According to the P1 selection signal, the module selects from inputs IN1 to IN8 and outputs the value of the selected input.                      If P1 = 0, then <math>OUT = P3 \times IN1 + P2</math>.                      If P1 = 1, then <math>OUT = P3 \times IN2 + P2</math>.                      If P1 = 2, then <math>OUT = P3 \times IN3 + P2</math>.                      If P1 = 3, then <math>OUT = P3 \times IN4 + P2</math>.                      If P1 = 4, then <math>OUT = P3 \times IN5 + P2</math>.                      If P1 = 5, then <math>OUT = P3 \times IN6 + P2</math>.                      If P1 = 6, then <math>OUT = P3 \times IN7 + P2</math>.                      If P1 = 7, then <math>OUT = P3 \times IN8 + P2</math>.                      If P1 &gt; 0 to 7, then <math>OUT = P3 \times IN1 + P2</math>.</p> <p><b>[TIP]</b> Bias default P2 = 0 Ratio default P3 = 1000(1.000) Configurable range of ratio P3 = 1 to 9999 (where, the physical range of data is 0.001 to 9.999)</p>	
<p>⊙: Signed 4-byte data; ○: Signed 2-byte data; ●: Flag of 0 or 1; ×: No output</p>				

Module No.	<b>70</b>		Category	Logical Operation
Module Name	Edge-triggered Counter		Module Code Name	<b>ECOUNTER</b>
Module Input			<b>[Computational Expression]</b> If IN3 changes (from 0 to 1 or from 1 to 0), then OUT = previous OUT + P4.	
IN1	●	Enable flag		
IN2	●	Initialization flag		
IN3	●	Counter input		
IN4	○	Initial value (for incremental and decremental counting)		
IN5				
IN6				
IN7				
IN8				
Module Parameter				
P1	○	Limiting action specification		
P2	○	Counter type specification		
P3	○	Counter input type specification		
P4	○	Augend or subtrahend		
Module Output				
OUT	○	Current value of edge-triggered counter		
Work Area	3			
Limitation on Usage				
<p><b>[TIP]</b>                  IN1: Enable flag (IN1 = 0: Stop counting momentarily; IN1 = 1: Continue counting)                  IN2: The module resets the counter if IN2 = 1, where OUT = 0 (irrelevant of the IN1 value).                  IN4: Initial value for decremental counting (P2 = 1)                  P1: Limiting action specification (P1 = 0: Limit; P1 = 1: Do not limit)                  If limited, the incremental counter stops at FFFFh (65535 in the decimal system) and the decremental counter at 0h (0 in the decimal system).                  If not limited, the counter continues counting.                  For example, if the module operates as a decremental counter and the count is 2 and the subtrahend is 4, the next count is FFFEh (65534 in the decimal system).                  P2: Counter type specification (P2 = 0: incremental counter; P2 = 1: decremental counter)                  P3: Counter input type specification (P3 = 0: rising-edge counter; P3 = 1: falling-edge counter; P3 = 2: rising-and falling-edge counter)                  P4: Augend if the module is operated as an incremental counter (P2 = 0); subtrahend if the module is operated as a decremental counter (P2 = 1);</p> <p><b>[NOTE]</b>                  Operation when no limiting action is specified                  ¥ If the incremental counter is specified, then <math>OUT = \text{previous } OUT + P4 - 10000h</math> (65536 in the decimal system) + IN4.                  ¥ If the decremental counter is specified, then <math>OUT = \text{previous } OUT - P4 + IN4 + 1</math></p> <p><b>[Example]</b>                  When the addition counter is selected (P2 = 0)                  FFFFh — Limiting action: ON (P1 = 0)      FFFFh — Limiting action: OFF (P1 = 1)                    IN4 (Initial value)      IN4 (Initial value)                  Start count      Start count</p>				
<p>◎: Signed 4-byte data; ○: Signed 2-byte data; ●: Flag of 0 or 1; ×: No output</p>				



Module No.	<b>70</b>	Category	Logical Operation
Module Name	Edge-triggered Counter	Module Code Name	<b>ECOUNTER</b>

**[Explanation]**

The basic concept of this module is the same as the concept for the COUNTER and DCOUNTER modules, except that the ECOUNTER module allows you to specify either "rising-edge" or "falling-edge" counting. The following practical example shows a case where the initial value for decremental counting (IN4) is set and the counter is decremented by the subtrahend (P4) each time the rising edge of the counter input (IN3) occurs. (In the example, IN4 = 10 and P4 = 2.)

**Example of Operation**

Decremental counter with no limiting action (where, the subtrahend is 2 and the counter input is triggered with each rising edge)

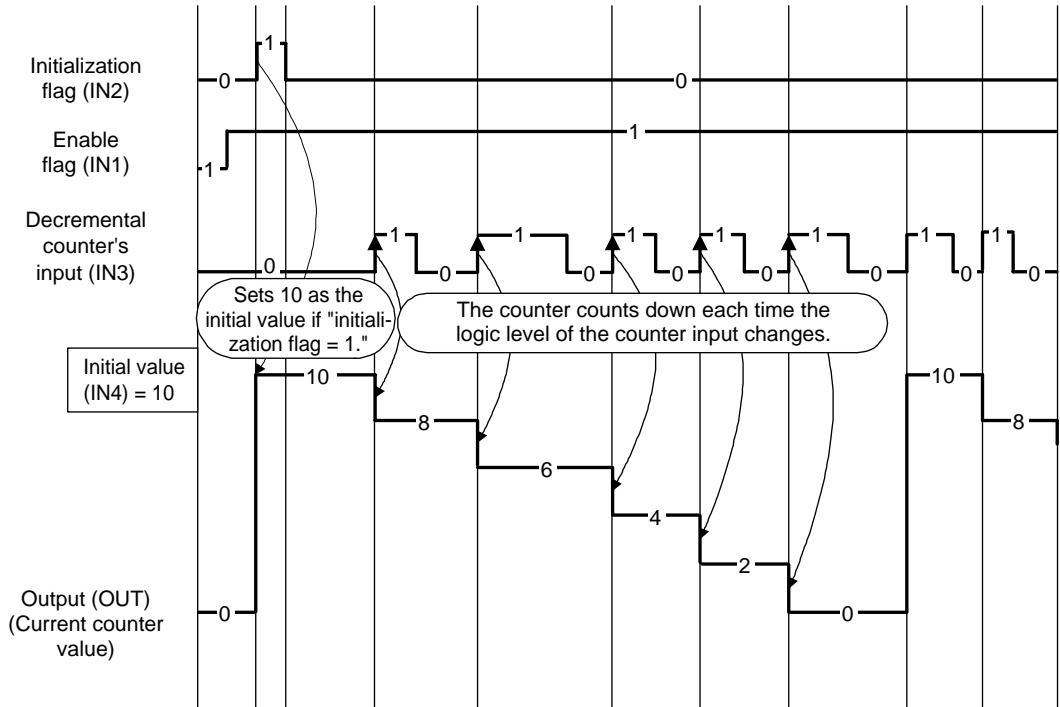

**[NOTE]**

The value of OUT is reset to 0 upon power failure.

⊙: Signed 4-byte data; ○: Signed 2-byte data; ●: Flag of 0 or 1; ×: No output

Module No.	<b>71</b>		Category	Special Operation
Module Name	Edge-triggered Timer		Module Code Name	<b>ETIMER</b>
Module Input			<p><b>[Computational Expression]</b>                      If the timer reaches 0, the output is set to 1; otherwise, the output remains set to 0.</p>	
IN1	●	Enable flag		
IN2	●	Initialization flag		
IN3	●	Timer flag		
IN4	○	Initial value		
IN5				
IN6				
IN7				
IN8				
Module Parameter				
P1	●	Auto-initialization selection flag		
P2	○	Timer input type specification		
P3				
P4				
Module Output				
OUT	●	Time-out flag		
Work Area	4			
Limitation on Usage				
			<p>If IN1 = 0, the timer stops.                      If IN1 = 1, subtract 1 from timer value when IN3 changes (from 0 to 1 or vice versa).                      If IN2 = 1, the timer value equals IN4 (irrelevant of the IN1 value).</p> <p><b>[TIP]</b>                      The timer value depends on the reference clock (timer flag) and control period.</p> <p>If P1 = 0, the timer stops when it reaches the end of operation and OUT is set to 1.                      If P1 = 1, the timer is set to the initial value when the timer reaches the end of operation resulting in a change in the timer flag and OUT is set to 1; thus, the timer resumes operation.</p> <p><b>[TIP]</b>                      IN1: Enable flag (IN1 = 0: Stop running; IN1 = 1: Continue to run)                      P2: Timer input type selection (P2 = 0: rising edge; P2 = 1: falling edge)</p> <p><b>[See Also]</b>                      "Timer flag" –Subsection 5.15.3, "Timer Function".</p>	

◎: Signed 4-byte data; ○: Signed 2-byte data; ●: Flag of 0 or 1; ×: No output

Module No.	<b>71</b>	Category	Special Operation
Module Name	Edge-triggered Timer	Module Code Name	<b>ETIMER</b>

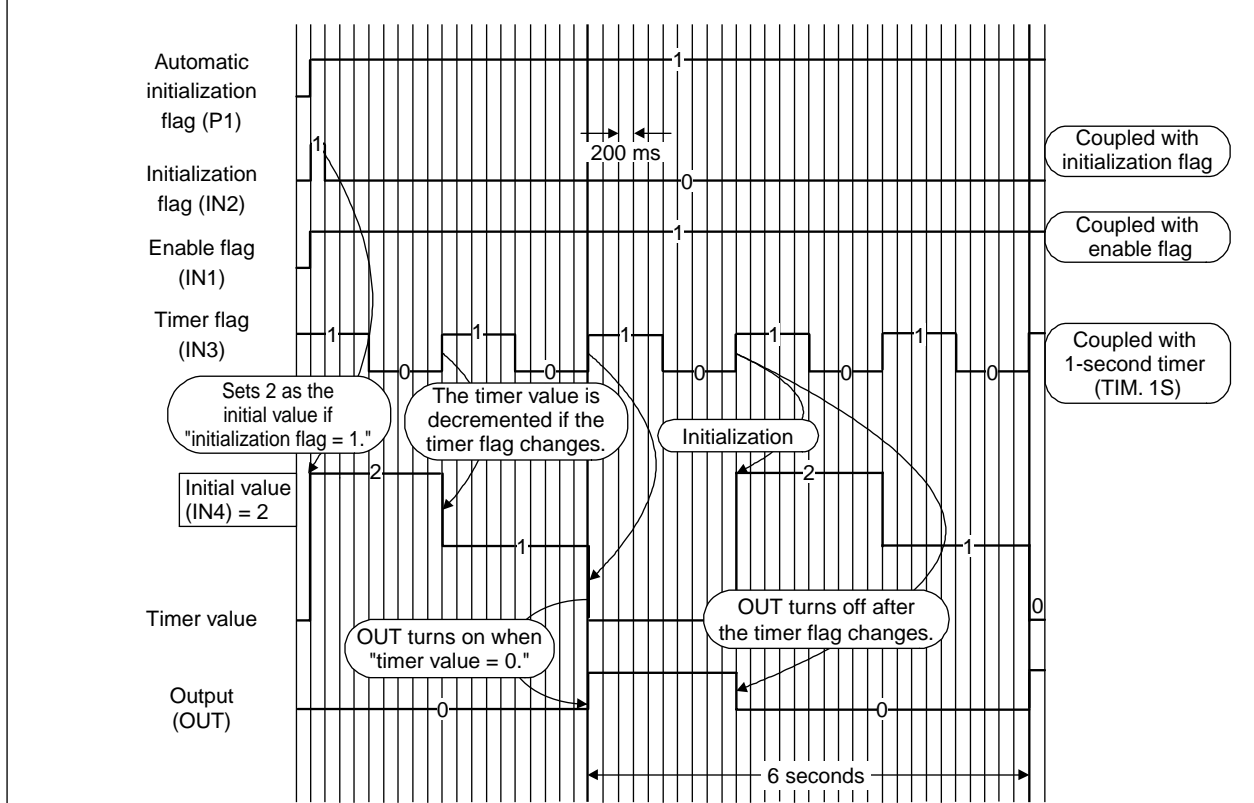

**[NOTE]**  
The value of OUT is reset to 0 upon power failure.

⊙: Signed 4-byte data; ○: Signed 2-byte data; ●: Flag of 0 or 1; ×: No output

Module No.	<b>72</b>		Category	Special Operation
Module Name	Detection of Change at Edge		Module Code Name	<b>ECHGDET</b>
Module Input			<b>[Computational Expression and Explanation]</b> If IN1 changes (from 0 to 1 or vice versa), OUT = 1 for one control period.	
IN1	●	Input 1		
IN2				
IN3				
IN4				
IN5				
IN6				
IN7				
IN8				
Module Parameter				
P1	●	Input type specification		
P2				
P3				
P4				
Module Output				
OUT	●	Result of change detection		
Work Area	1			
Limitation on Usage			<p>This module is used to generate timing signals for processing. If reset, the module retains the input and the output is set to 0.</p> <p><b>[TIP]</b> P1: Input type specification (P1 = 0: rising edge; P1 = 1: falling edge)</p> <ul style="list-style-type: none"> <li>The following figure is an example of a timing chart where the detection of a rising edge provides an output over one control period.</li> </ul>	
			<p>◎: Signed 4-byte data; ○: Signed 2-byte data; ●: Flag of 0 or 1; ×: No output</p>	

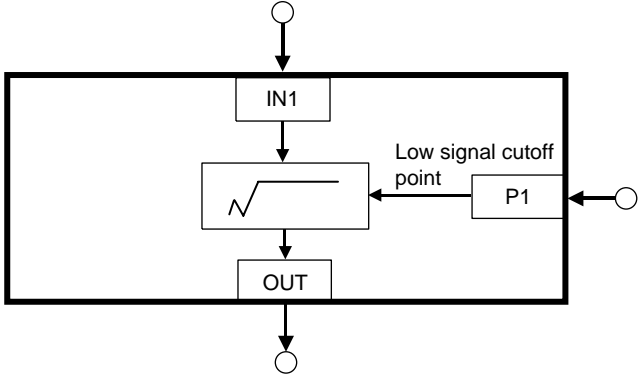
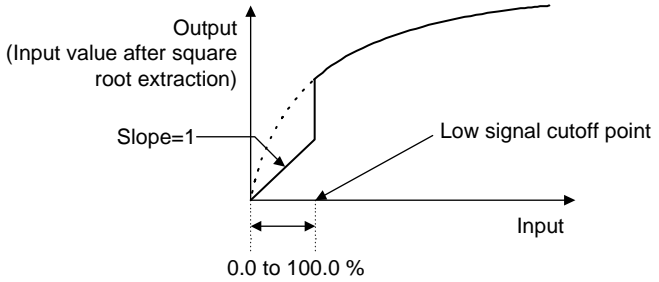
Module No.	<b>73</b>		Category	Special Operation
Module Name	Square Root Extraction 2		Module Code Name	<b>SQR2</b>
Module Input			<p><b>[Computational Expression]</b>  <math>OUT = \sqrt{IN1}</math>, where low signal cutoff is applied at point P1</p> 	
IN1	<input type="radio"/>	Input 1		
IN2				
IN3				
IN4				
IN5				
IN6				
IN7				
IN8				
Module Parameter			<p><b>[Explanation]</b>                  The module replaces a value on the 0 to 30000 scale with a value on the 0 to 1 scale to extract the square root of that value; it then converts the result back to a value on the 0 to 30000 scale for output.                  Example: The square root of 30000 results in the value 30000.                  The square root of 15000 results in the value 21213.</p>	
P1	<input type="radio"/>	Low signal cutoff point		
P2				
P3				
Module Output			<p>If <math>IN1 &lt; P1</math>, then <math>OUT = IN1</math> (low signal cutoff)</p> 	
OUT	<input type="radio"/>	Result of square root extraction		
Work Area				
Limitation on Usage			<p><b>[TIP]</b>                  Use the SQR module (Module No. 44) when an output below the low signal cutoff point needs to be zeroed.</p>	

⊙: Signed 4-byte data; ○: Signed 2-byte data; ●: Flag of 0 or 1; ×: No output

Module No.	<b>74</b>		Category	Special Operation
Module Name	Flow Sum		Module Code Name	<b>FLWSUM</b>
Module Input			<p><b>[Explanation]</b>                      The module totalizes IN3 and outputs the total sum.                      If IN2 = 1, the summation is initialized.</p>	
IN1	●	Enable flag		
IN2	●	Initialization flag		
IN3	○	Instantaneous flow		
IN4	○	Initial value (for incremental and decremental counting)		
IN5				
IN6				
IN7				
IN8				
Module Parameter				
P1	○	Span of instantaneous flow		
P2	●	Addition/subtraction specification (0, 1)		
P3	○	Unit of time (0 to 2)		
P4				
Module Output				
OUT	○	Sum		
Work Area	7			
Limitation on Usage				
			<p><b>[TIP]</b>                      IN1: Enable flag (IN1 = 0: Stop totaling momentarily; IN1 = 1: Continue totaling)                      IN2: Initialization flag (IN2 = 0: Don't initialize; IN2 = 1: Initialize)                      P2: Addition/subtraction specification (P2 = 0: addition; P2 = 1: subtraction)                      P3: Unit of time (P3 = 0: hour; P3 = 1: minute; P3 = 2: day)</p> <p><b>[NOTE]</b>                      The value of OUT is reset to 0 upon power failure.</p>	
			<p>⊙: Signed 4-byte data; ○: Signed 2-byte data; ●: Flag of 0 or 1; ×: No output</p>	

Module No.	<b>74</b>	Category	Special Operation
Module Name	Flow Sum	Module Code Name	<b>FLWSUM</b>

**[Explanation]**

The following figure shows the timing chart of flow summation during subtraction.

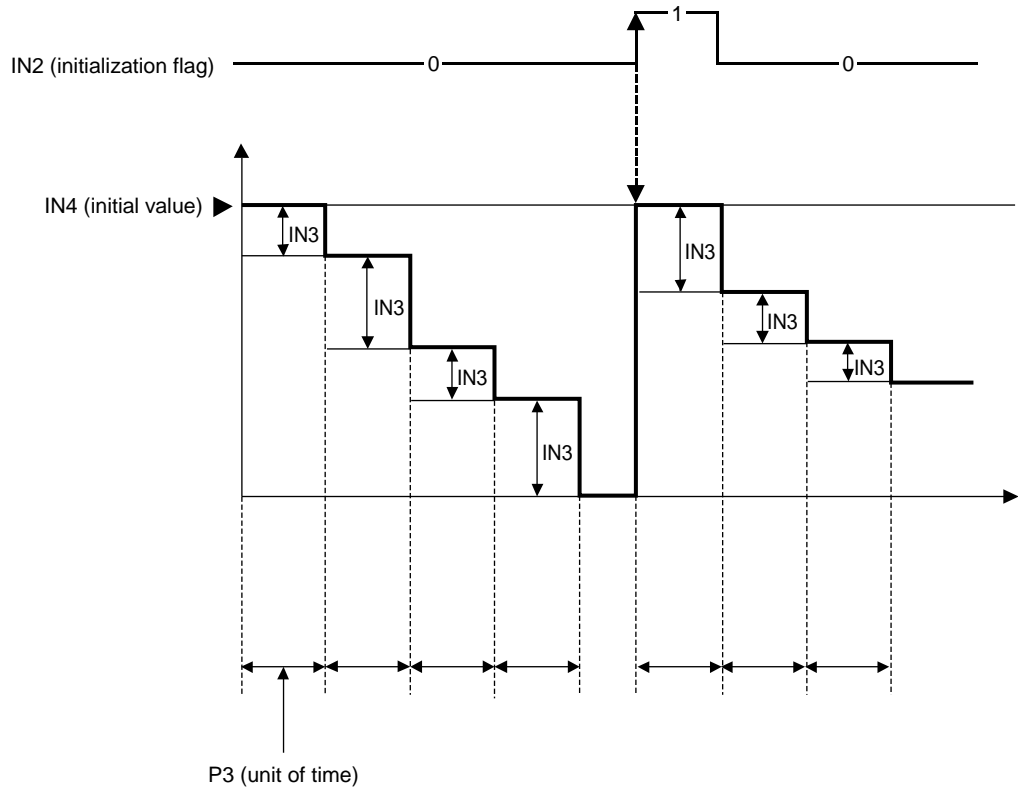

The following figure shows the timing chart of flow summation during addition.

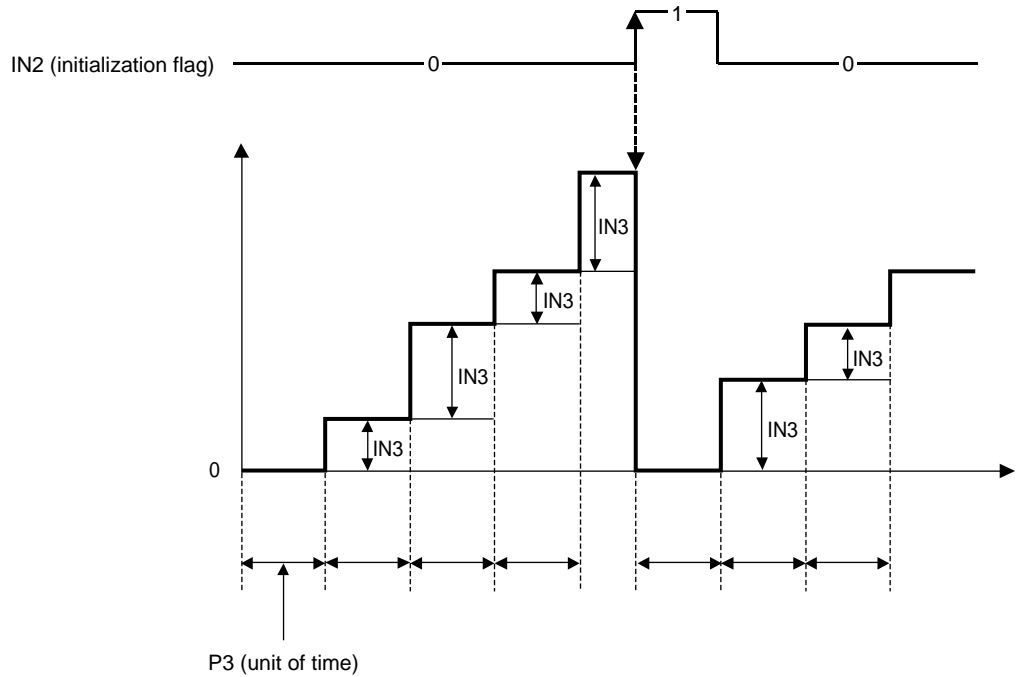

◎: Signed 4-byte data; ○: Signed 2-byte data; ●: Flag of 0 or 1; ×: No output

Module No.	<b>75</b>		Category	Special Operation
Module Name	Integrated Pulse Output		Module Code Name	<b>CPO</b>
Module Input			<p><b>[Explanation]</b>                      Integrated pulse output = Integration factor (P1) × instantaneous flow (IN3)                      [Unit: pulse/hour]</p> <p>The module integrates IN3 and outputs pulses by the number according to the P1 value.                      Example) When P1 = 500 and IN3 = 75.0%,  <math>500 \times 0.75 = 375</math> pulses/hour</p> <p>If IN2 = 1, the integrated value is initialized.                      The ON time of pulses is the same as the control period.</p>	
IN1	●	Enable flag		
IN2	●	Initialization flag		
IN3	○	Instantaneous flow		
IN4				
IN5				
IN6				
IN7				
IN8				
Module Parameter				
P1	○	Integration factor		
P2	○	Low signal cut-off point		
P3				
P4				
Module Output				
OUT	●	Pulse output		
Work Area	7			
Limitation on Usage				
<p><b>[TIP]</b>                      IN1 : Enable flag (IN1 = 0: Stop integration; IN1 = 1: Continue integration)                      IN2 : Initialization flag (IN2 = 0: Do not initialize; IN2 = 1: Initialize)                      P1 : Integration factor (unit: pulse/hour)                      Setting range: 100 to 8000                      P2 : Low signal cut-off point (%)                      Computation data value ranging from 0 to 30000 corresponds to 0.0 to 100.0%.                      Input values no more than P2 value will not be integrated.</p> <p><b>[NOTE]</b>                      If you set P1 beyond its setting range, the pulse output will be limited within the setting range.                      When the control period is 500 msec, the number of pulses is limited to 3600.                      The value of OUT is reset to 0 upon power failure.</p>				
<p>◎: Signed 4-byte data; ○: Signed 2-byte data; ●: Flag of 0 or 1; ×: No output</p>				

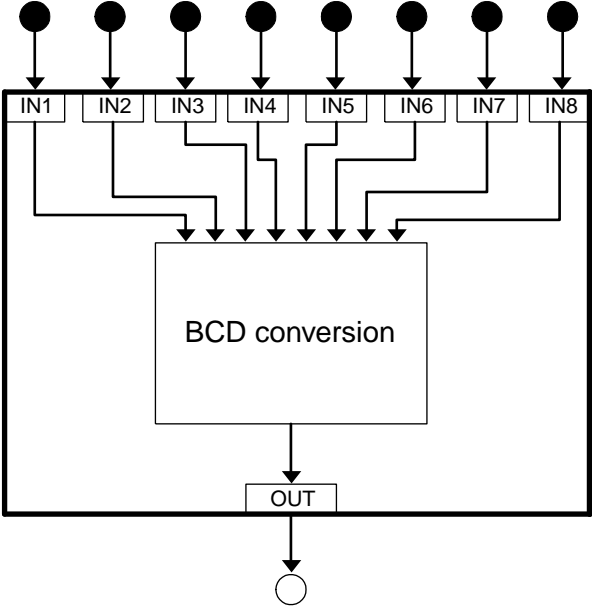

Module No.	<b>76</b>		Category	Logical Operation
Module Name	BCD Conversion		Module Code Name	<b>BCD</b>
Module Input			<p><b>[Computational Expression]</b>  <math display="block">OUT = IN1 \times 2^0 + IN2 \times 2^1 + IN3 \times 2^2 + IN4 \times 2^3 + IN5 \times 2^4 + IN6 \times 2^5 + IN7 \times 2^6 + IN8 \times 2^7</math></p> 	
IN1	●	Input 1		
IN2	●	Input 2		
IN3	●	Input 3		
IN4	●	Input 4		
IN5	●	Input 5		
IN6	●	Input 6		
IN7	●	Input 7		
IN8	●	Input 8		
Module Parameter				
P1				
P2				
P3				
P4				
Module Output				
OUT	○	Decimal number		
Work Area				
Limitation on Usage				

**[Explanation]**

The module converts a bit string of IN1 through IN8 into a decimal number and outputs the result.

**[Example]**

- 1) When IN1 = 1, IN2 = 1, IN3 = 1, IN4 = 1, IN5 = 1, IN6 = 1, IN7 = 1, IN8 = 1;  
 $1 \times 2^0 + 1 \times 2^1 + 1 \times 2^2 + 1 \times 2^3 + 1 \times 2^4 + 1 \times 2^5 + 1 \times 2^6 + 1 \times 2^7 = 255$
- 2) When IN1 = 1, IN2 = 0, IN3 = 1, IN4 = 0, IN5 = 1, IN6 = 0, IN7 = 1, IN8 = 0;  
 $1 \times 2^0 + 0 \times 2^1 + 1 \times 2^2 + 0 \times 2^3 + 1 \times 2^4 + 0 \times 2^5 + 1 \times 2^6 + 0 \times 2^7 = 85$

○: Signed 4-byte data; ○: Signed 2-byte data; ●: Flag of 0 or 1; ×: No output

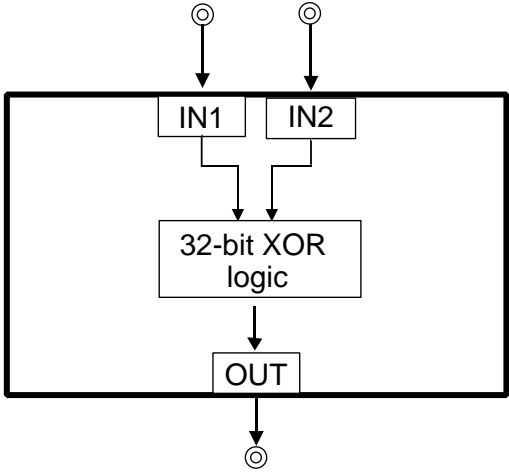
Module No.	<b>77</b>		Category	Logical Operation										
Module Name	XOR (Long Word) Logic		Module Code Name	<b>XORW</b>										
Module Input			<p><b>[Computational Expression]</b>  <math>OUT = IN1 \vee IN2</math></p> 											
IN1	⊙	Input 1												
IN2	⊙	Input 2												
IN3														
IN4														
IN5														
IN6														
IN7														
IN8														
Module Parameter														
P1														
P2														
P3														
P4														
Module Output			<p><b>[Explanation]</b>                      The module outputs the XOR logic of IN1 and IN2 in long word (32 bits) unit.</p> <p><b>Example of Operation</b></p> <table border="0" style="margin-left: 20px;"> <tr> <td style="text-align: right;">IN1</td> <td style="border: 1px solid black; padding: 2px;">1 0 1 0 0 1 0 1 0 1 0 1 0 1 1 1 1 0 0 0 1 0 1 0 0 0 1 1 1 1 0 1 1</td> </tr> <tr> <td></td> <td style="text-align: center;">XOR</td> </tr> <tr> <td style="text-align: right;">IN2</td> <td style="border: 1px solid black; padding: 2px;">0 0 1 0 0 0 0 0 0 0 0 0 0 0 0 0 1 1 0 0 1 0 0 0 0 1 0 1 1 0 0 0</td> </tr> <tr> <td></td> <td style="text-align: center;">↓</td> </tr> <tr> <td style="text-align: right;">OUT</td> <td style="border: 1px solid black; padding: 2px;">1 0 0 0 0 1 0 1 0 1 0 1 1 1 1 0 1 1 1 0 0 0 0 1 0 1 1 0 0 1 1</td> </tr> </table>		IN1	1 0 1 0 0 1 0 1 0 1 0 1 0 1 1 1 1 0 0 0 1 0 1 0 0 0 1 1 1 1 0 1 1		XOR	IN2	0 0 1 0 0 0 0 0 0 0 0 0 0 0 0 0 1 1 0 0 1 0 0 0 0 1 0 1 1 0 0 0		↓	OUT	1 0 0 0 0 1 0 1 0 1 0 1 1 1 1 0 1 1 1 0 0 0 0 1 0 1 1 0 0 1 1
IN1	1 0 1 0 0 1 0 1 0 1 0 1 0 1 1 1 1 0 0 0 1 0 1 0 0 0 1 1 1 1 0 1 1													
	XOR													
IN2	0 0 1 0 0 0 0 0 0 0 0 0 0 0 0 0 1 1 0 0 1 0 0 0 0 1 0 1 1 0 0 0													
	↓													
OUT	1 0 0 0 0 1 0 1 0 1 0 1 1 1 1 0 1 1 1 0 0 0 0 1 0 1 1 0 0 1 1													
OUT	⊙	XOR (Long word) logic result												
Work Area														
Limitation on Usage														

⊙: Signed 4-byte data; ○: Signed 2-byte data; ●: Flag of 0 or 1; ×: No output

Module No.	<b>78</b>		Category	Special Function
Module Name	Data Save		Module Code Name	<b>DATASAVE</b>
Module Input			<p><b>[Explanation]</b>                  When P2 = 1, the module writes IN1 into the register specified by P1.                  IN1 data range: 00000000 to FFFFFFFF                  Registers that can be written by this module: D1041 to D1060</p>	
IN1	<input checked="" type="radio"/>	Data to save		
IN2	<input type="radio"/>			
IN3	<input type="radio"/>			
IN4	<input type="radio"/>			
IN5	<input type="radio"/>			
IN6	<input type="radio"/>			
IN7	<input type="radio"/>			
IN8	<input type="radio"/>			
Module Parameter				
P1	<input type="radio"/>	Number of the register where data is saved (immediate address)		
P2	<input checked="" type="radio"/>	Write flag		
P3	<input type="radio"/>			
P4	<input type="radio"/>			
Module Output				
OUT	<input checked="" type="radio"/>			
Work Area				
Limitation on Usage			<p><b>[TIP]</b>                  P1 : D register number of the register where data is written.                  Immediate address: 1041 to 1050 (for word data)                  Immediate address: 1051, 1053, 1055, 1057, 1059 (for long-word data)                  P2 : Write flag (writes when P2 = 1)</p>	

⊙: Signed 4-byte data; ○: Signed 2-byte data; ●: Flag of 0 or 1; ×: No output

---

Blank Page

# 5. UP750 Data Storage Areas (D Registers and I Relays)

This chapter explains the D registers and I relays that store process data, flag data and parameter data. Data used in custom computations are also stored in these D registers and I relays.

## ■ Interpretation of Lists of D Registers (D Register Map Tables)

This section explains how to read the “D Register Map” tables in this chapter.

In the example shown below, the number in the leftmost column denotes a register number “1301”.

Each register code name in the D register Map tables represents a specific process data item, operation parameter, setup parameter, input block data, output block data or other data item such as flag.

Title of Register Map Table		
No.	Register name	R/W
1301	AIN1	R

(1) D register number

(2) Read/write permission  
(R: read; W: write)

050001E.EPS

### See Also

GREEN Series Communication Reference (IM 05G01B02-02E) for details on operation parameters and setup parameters.

## ■ Name of D Registers

The base names of some D registers are preceded by a combination of a number and then a period, and/or followed by a combination of a period and then a number, as shown in format Y.xxx.X, where Y represents the PID group number and X denotes the loop number.

### Examples:

- The name 3.SP.1 means the SP in group 3 and for loop 1.
- The name OUT.2 means the OUT for loop 2.



### NOTE

It is prohibited to read/write data from/to the registers of the blank cells in the register map tables. If you attempt to do so, the UP750 may not operate properly.

## 5.1 Configuration of UP750 Data Storage Areas

### ■ Classification of D Registers

The D registers are classified as shown below.

Register No.	Area and Data Categories		Description	Reference
D0001 to 0049	Process data area (Note 1)	Data displayed for operation	PV, SP, OUT, and others	Section 5.4
D0050 to 0100	User area (Note 2), 	—	If a graphic panel is used, this area is used for communication with the graphic panel.	Section 5.4
D0101 to 0200	Program data area	Program setting parameters	Local setpoint, PID number, event setting, and others	Section 5.5
D0201 to 0230	Operation parameters (Note 1)	Operation mode parameters	A/M, C/A/M, MOUT, and others	Section 5.6
D0231 to 0300		Computation parameters	AT, SC, BS, FL, and others	Section 5.6
D0301 to 0700		PID parameters for Loop 1 and 2	P, I, D, and others	Sections 5.7 and 5.8
D0701 to 0800		Ten-segment linearizer parameters and USER parameters	1.A1 to 1.PMD, U1 to U8 and others	Section 5.9
D0801 to 0900	Display messages	Message texts	Display messages (each comprising up to 20 alphanumeric characters)	Section 5.9
D0901 to 1000	Setup parameters (Note 1)	Control action parameters	SP, ALM, CTL	Section 5.10
D1001 to 1100		Loop-common function parameters	AIN, RET, TRND, LOCK	Section 5.10
D1101 to 1200		I/O configuration parameters	CSEL, DO, DI, C.PYS	Section 5.10
D1201 to 1300		Controller mode, PV input, and control output parameters	UTMD, IN, OUT, R485, INIT	Section 5.11
D1301 to 1500	User definitions (custom computation area)	Input block data	Block input/output and module output	Sections 5.2 and 5.3
D1501 to 1700		Output block data		

Note 1: Data for process values, operation parameters and setup parameters are stored in the types (EU, EUS, %, or ABS without the decimal point) indicated in the Operation Parameter Lists and Setup Parameter Lists of UP750 User's Manual for Single-loop Control (IM 05E01B02-01E to -07E). For ON/OFF data, the OFF and ON states are represented by 0 and 1, respectively. D registers D0001 to 0049 are read-only.

Note 2: When communicating with a graphic panel, do not write to or read from this area (D0050 to 0100) because this area is reserved for 16-bit register data used by graphic panels or other.

**[See Also]** Section 5.4, "Process Data and User Area."

050101E.EPS



#### NOTE

It is prohibited to read/write data from/to the registers of the blank cells in the register map tables. If you attempt to do so, the UP750 may not operate properly.

## ■ Classification of I Relays

The I relays are classified as shown below.

I Relay No.	Type of Status	Description	Remarks	Reference
1 to 192	Status	Bit information of I relays 1 to 192 is the same as that of D registers.		Section 5.12
193 to 384	ON status	Bit information of I relays 193 to 384 is the same as that of D registers.	When the status changes from OFF to ON, the corresponding relay is turned on for one control period.	Section 5.13
385 to 576	OFF status	Bit information of I relays 385 to 576 is the same as that of D registers.	When the status changes from ON to OFF, the corresponding relay is turned on for one control period.	Section 5.14
577 to 720	Status	Bit information of I relays 593 to 656 and 689 to 720 is the same as that of D registers.		Section 5.15
721 to 2048	User area	You can use this area freely without affecting the control function of the controller.		Section 5.15

050102E.EPS

Except for the I relays listed below, I relay code names are the same as the code names of the bits contained in the corresponding D registers.

I Relay No.	Code	Event
*0593 to 0596	PIDNO1.0 to 1.3	PID number for Loop 1
*0609 to 0612	PIDNO2.0 to 2.3	PID number for Loop 2
0657 to 0661	TIM.1S to TIM.1M	1-second timer to 1 minute timer
0672 to 0674	PON, PV2	Power-on and PV2 lamp state
0681 to 0687	DV1- to DV2+	Deviation state for Loop 1 and Loop 2
0689 to 0693	ALO11 to ALO14	Status of instrument alarm outputs

\* : The information of I relays 0593 to 0612 is represented by 4-digit binary codes, from 0000 (0 in decimal) to 1000 (8 in decimal), which are formed by the bit combination of four I relays. The lowest-numbered I relay in each set signifies the LSB.

050103E.EPS

## 5.2 Input Block Data Storage Area (D Registers 1301 to 1500)

### ■ Data Storage Area Map

Area for Input Block											
No.	Register name	R/W	No.	Register name	R/W	No.	Register name	R/W	No.	Register name	R/W
1301	AIN1	R	1351			1401	IMO1L	R	1451	IMO26L	R
1302	AIN2	R	1352			1402	IMO1H	R	1452	IMO26H	R
1303	AIN3	R	1353			1403	IMO2L	R	1453	IMO27L	R
1304			1354			1404	IMO2H	R	1454	IMO27H	R
1305			1355			1405	IMO3L	R	1455	IMO28L	R
1306			1356			1406	IMO3H	R	1456	IMO28H	R
1307			1357			1407	IMO4L	R	1457	IMO29L	R
1308			1358			1408	IMO4H	R	1458	IMO29H	R
1309			1359			1409	IMO5L	R	1459	IMO30L	R
1310			1360			1410	IMO5H	R	1460	IMO30H	R
1311			1361	PROG	R	1411	IMO6L	R	1461	IMO31L	R
1312			1362	RESET	R	1412	IMO6H	R	1462	IMO31H	R
1313			1363	LOCAL	R	1413	IMO7L	R	1463	IMO32L	R
1314			1364	HOLD	R	1414	IMO7H	R	1464	IMO32H	R
1315			1365	ADV	R	1415	IMO8L	R	1465	IMO33L	R
1316			1366	A/M.1	R	1416	IMO8H	R	1466	IMO33H	R
1317			1367	A/M.2	R	1417	IMO9L	R	1467	IMO34L	R
1318			1368	LSP/CAS	R	1418	IMO9H	R	1468	IMO34H	R
1319			1369	PTNO.b0	R	1419	IMO10L	R	1469	IMO35L	R
1320			1370	PTNO.b1	R	1420	IMO10H	R	1470	IMO35H	R
1321			1371	PTNO.b2	R	1421	IMO11L	R	1471	IMO36L	R
1322			1372	PTNO.b3	R	1422	IMO11H	R	1472	IMO36H	R
1323			1373	PTNO.b4	R	1423	IMO12L	R	1473	IMO37L	R
1324			1374	PTNO.b5	R	1424	IMO12H	R	1474	IMO37H	R
1325			1375	PTNO.b6	R	1425	IMO13L	R	1475	IMO38L	R
1326			1376	PTNO.b7	R	1426	IMO13H	R	1476	IMO38H	R
1327			1377	PTNO.b8	R	1427	IMO14L	R	1477	IMO39L	R
1328			1378	DP1	R	1428	IMO14H	R	1478	IMO39H	R
1329			1379	DP2	R	1429	IMO15L	R	1479	IMO40L	R
1330			1380	MG1	R	1430	IMO15H	R	1480	IMO40H	R
1331	PVIN.1	R	1381	MG2	R	1431	IMO16L	R	1481	IMO41L	R
1332	PVIN.2	R	1382	MG3	R	1432	IMO16H	R	1482	IMO41H	R
1333	RSPIN.1	R	1383	MG4	R	1433	IMO17L	R	1483	IMO42L	R
1334	RSPIN.2	R	1384			1434	IMO17H	R	1484	IMO42H	R
1335	GAIN.1	R	1385			1435	IMO18L	R	1485	IMO43L	R
1336	GAIN.2	R	1386			1436	IMO18H	R	1486	IMO43H	R
1337	TRG.1	R	1387			1437	IMO19L	R	1487	IMO44L	R
1338	TRG.2	R	1388			1438	IMO19H	R	1488	IMO44H	R
1339	TRF.1	R	1389			1439	IMO20L	R	1489	IMO45L	R
1340	TRF.2	R	1390			1440	IMO20H	R	1490	IMO45H	R
1341			1391			1441	IMO21L	R	1491	IMO46L	R
1342			1392			1442	IMO21H	R	1492	IMO46H	R
1343			1393			1443	IMO22L	R	1493	IMO47L	R
1344			1394			1444	IMO22H	R	1494	IMO47H	R
1345			1395			1445	IMO23L	R	1495	IMO48L	R
1346			1396			1446	IMO23H	R	1496	IMO48H	R
1347			1397			1447	IMO24L	R	1497	IMO49L	R
1348			1398			1448	IMO24H	R	1498	IMO49H	R
1349			1399			1449	IMO25L	R	1499	IMO50L	R
1350			1400			1450	IMO25H	R	1500	IMO50H	R

050201E.EPS



### 5.2.1 Area for Storing Data Fed to the Input Block

Register No.	Category	Description	Remarks
1301 to 1303	Analog signal	AIN1: Analog input 1 AIN2: Analog input 2 AIN3: Analog input 3	Data fed to the input block

050202E.EPS

### 5.2.2 Area for Storing Data Fed from the Input Block

Register No.	Category	Description	Remarks
1331 to 1340	Analog signal	PVIN.1: Loop 1 PV input PVIN.2: Loop 2 PV input RSPIN.1: Loop 1 remote setpoint input RSPIN.2: Loop 2 remote setpoint input GAIN.1: Loop 1 gain setting value GAIN.2: Loop 2 gain setting value TRG.1: Loop 1 tracking input TRG.2: Loop 2 tracking input TRF.1: Loop 1 tracking flag TRF.2: Loop 2 tracking flag	Data fed from the input block
1343 to 1360	Status signal	PROG: Program start mode RESET: Reset mode LOCAL: Local mode HOLD: Hold mode ADV: Advance mode A/M.1: Loop 1 AUTO/MAN mode A/M.2: Loop 2 AUTO/MAN mode LSP/CAS: Loop 1 Local/Cascade mode PTNO.b0: Bit 0 of program pattern setting PTNO.b1: Bit 1 of program pattern setting PTNO.b2: Bit 2 of program pattern setting PTNO.b3: Bit 3 of program pattern setting PTNO.b4: Bit 4 of program pattern setting PTNO.b5: Bit 5 of program pattern setting PTNO.b6: Bit 6 of program pattern setting PTNO.b7: Bit 7 of program pattern setting PTNO.b8: Bit 8 of program pattern setting DP1: Operating display selection 1 DP2: Operating display selection 2 MG1: Interruptive message display 1 MG2: Interruptive message display 2 MG3: Interruptive message display 3 MG4: Interruptive message display 4	

050203E.EPS

### 5.2.3 Area for Storing Output Data of Input Block Computation Modules

Register No.	Category	Description	Remarks
1401 to 1500	Output of computation modules	These registers store the output values of computation modules created when custom computation is configured. The output values are stored in the order they are registered and in units of two words. IMO1L and IMO1H: Computation module that is 1st in the order of execution IMO2L and IMO2H: Computation module that is 2nd in the order of execution IMO3L and IMO3H: Computation module that is 3rd in the order of execution : : : IMO47L and IMO47H: Computation module that is 47th in the order of execution IMO48L and IMO48H: Computation module that is 48th in the order of execution IMO49L and IMO49H: Computation module that is 49th in the order of execution IMO50L and IMO50H: Computation module that is 50th in the order of execution  Codes with the suffix L denote a lower-order word and codes with the suffix H denote a higher-order word.	When configuring custom computation, specify the computation module's output data register as connection information by addressing the lower-order word.

050204E.EPS

## 5.3 Output Block Data Storage Area (D Registers 1501 to 1700)

### ■ Data Storage Area Map

Area for Output Block											
No.	Register name	R/W	No.	Register name	R/W	No.	Register name	R/W	No.	Register name	R/W
1501	PV.1	R	1551	RDO251	R	1601	OMO1L	R	1651	OMO26L	R
1502	PV.2	R	1552	RDO252	R	1602	OMO1H	R	1652	OMO26H	R
1503	CSP.1	R	1553	RDO253	R	1603	OMO2L	R	1653	OMO27L	R
1504	CSP.2	R	1554	RDO254	R	1604	OMO2H	R	1654	OMO27H	R
1505	OUT.1	R	1555	RDO255	R	1605	OMO3L	R	1655	OMO28L	R
1506	OUT.2	R	1556	RDO256	R	1606	OMO3H	R	1656	OMO28H	R
1507	HOUT.1	R	1557	RDO257	R	1607	OMO4L	R	1657	OMO29L	R
1508	HOUT.2	R	1558	RDO258	R	1608	OMO4H	R	1658	OMO29H	R
1509	COU.1	R	1559			1609	OMO5L	R	1659	OMO30L	R
1510	COU.2	R	1560			1610	OMO5H	R	1660	OMO30H	R
1511	RET1	R	1561			1611	OMO6L	R	1661	OMO31L	R
1512	RET2	R	1562			1612	OMO6H	R	1662	OMO31H	R
1513			1563			1613	OMO7L	R	1663	OMO32L	R
1514			1564			1614	OMO7H	R	1664	OMO32H	R
1515			1565			1615	OMO8L	R	1665	OMO33L	R
1516			1566			1616	OMO8H	R	1666	OMO33H	R
1517			1567			1617	OMO9L	R	1667	OMO34L	R
1518			1568			1618	OMO9H	R	1668	OMO34H	R
1519			1569			1619	OMO10L	R	1669	OMO35L	R
1520			1570			1620	OMO10H	R	1670	OMO35H	R
1521			1571			1621	OMO11L	R	1671	OMO36L	R
1522			1572			1622	OMO11H	R	1672	OMO36H	R
1523			1573			1623	OMO12L	R	1673	OMO37L	R
1524			1574			1624	OMO12H	R	1674	OMO37H	R
1525			1575			1625	OMO13L	R	1675	OMO38L	R
1526			1576			1626	OMO13H	R	1676	OMO38H	R
1527			1577			1627	OMO14L	R	1677	OMO39L	R
1528			1578			1628	OMO14H	R	1678	OMO39H	R
1529			1579			1629	OMO15L	R	1679	OMO40L	R
1530			1580			1630	OMO15H	R	1680	OMO40H	R
1531	OUT1A	R	1581			1631	OMO16L	R	1681	OMO41L	R
1532	OUT2A	R	1582			1632	OMO16H	R	1682	OMO41H	R
1533	OUT3A	R	1583			1633	OMO17L	R	1683	OMO42L	R
1534	OUT1R	R	1584			1634	OMO17H	R	1684	OMO42H	R
1535	OUT2R	R	1585			1635	OMO18L	R	1685	OMO43L	R
1536	DO1	R	1586			1636	OMO18H	R	1686	OMO43H	R
1537	DO2	R	1587			1637	OMO19L	R	1687	OMO44L	R
1538	DO3	R	1588			1638	OMO19H	R	1688	OMO44H	R
1539	DO4	R	1589			1639	OMO20L	R	1689	OMO45L	R
1540	DO5	R	1590			1640	OMO20H	R	1690	OMO45H	R
1541	DO6	R	1591			1641	OMO21L	R	1691	OMO46L	R
1542	DO7	R	1592			1642	OMO21H	R	1692	OMO46H	R
1543	RDO151	R	1593			1643	OMO22L	R	1693	OMO47L	R
1544	RDO152	R	1594			1644	OMO22H	R	1694	OMO47H	R
1545	RDO153	R	1595			1645	OMO23L	R	1695	OMO48L	R
1546	RDO154	R	1596			1646	OMO23H	R	1696	OMO48H	R
1547	RDO155	R	1597			1647	OMO24L	R	1697	OMO49L	R
1548	RDO156	R	1598			1648	OMO24H	R	1698	OMO49H	R
1549	RDO157	R	1599			1649	OMO25L	R	1699	OMO50L	R
1550	RDO158	R	1600			1650	OMO25H	R	1700	OMO50H	R

050301E.EPS

### 5.3.1 Area for Storing Data Fed to the Output Block

Register No.	Category	Description	Remarks
1501 to 1512	Computed data value	PV.1: Loop 1 PV value PV.2: Loop 2 PV value CSP.1: Loop 1 target setpoint value CSP.2: Loop 2 target setpoint value OUT.1: Loop 1 control output value OUT.2: Loop 2 control output value HOUT.1: Loop 1 heating-side control output value HOUT.2: Loop 2 heating-side control output value COUT.1: Loop 1 cooling-side control output value COUT.2: Loop 2 cooling-side control output value RET1: Retransmission output 1 RET2: Retransmission output 2	Data fed to the output block

050302E.EPS

### 5.3.2 Area for Storing Data Fed from the Output Block

Register No.	Category	Description	Remarks
1531 to 1535	Analog signal	OUT1A: Analog output 1 OUT2A: Analog output 2 OUT3A: Analog output 3 OUT1R: Relay control output 1 OUT2R: Relay control output 2	Data fed from the output block
1536 to 1542	Status signal	DO1 to DO3: Relay output DO4 to DO7: Open collector output	
1543 to 1558	I/O expansion module	RDO151 to RDO158: Contact output of expansion module 1 RDO251 to RDO258: Contact output of expansion module 2	

050303E.EPS

### 5.3.3 Area for Storing Output Data of Output Block Computation Modules

Register No.	Category	Description	Remarks
1601 to 1700	Output of computation modules	<p>These registers store the output values of computation modules created when custom computation is configured. The output values are stored in the order they are registered and in units of two words.</p> <p>OMO1L and OMO1H: Computation module that is the 1st in the order of execution                      OMO2L and OMO2H: Computation module that is the 2nd in the order of execution                      OMO3L and OMO3H: Computation module that is 3rd in the order of execution</p> <p style="text-align: center;">⋮</p> <p>OMO47L and OMO47H: Computation module that is 47th in the order of execution                      OMO48L and OMO48H: Computation module that is 48th in the order of execution                      OMO49L and OMO49H: Computation module that is 49th in the order of execution                      OMO50L and OMO50H: Computation module that is 50th in the order of execution</p> <p>Codes with the suffix L denote a lower-order word and codes with the suffix H denote a higher-order word.</p>	When configuring custom computation, specify the computation module's output data register as connection information by addressing the lower-order word.

050304E.EPS

# 5.4 Process Data Area and User Area (D Registers 1 to 100)

## ■ Data Storage Area Map

Process Data Area					
No.	Register name	R/W	No.	Register name	R/W
1	ADERROR	R	51		R/W
2	ERROR.1	R	52		R/W
3	PV.1	R	53		R/W
4	CSP.1	R	54		R/W
5	OUT.1	R	55		R/W
6	HOUT.1	R	56		R/W
7	COUT.1	R	57		R/W
8	MOD.1	R	58		R/W
9	PIDNO.1	R	59		R/W
10			60		R/W
11	ALM	R	61		R/W
12	PVEV	R	62		R/W
13	TMEV1	R	63		R/W
14	TMEV2	R	64		R/W
15	PTN	R	65		R/W
16	SEGNO	R	66		R/W
17	TIME	R	67		R/W
18	ERROR.2	R	68		R/W
19	PV.2	R	69		R/W
20	CSP.2	R	70		R/W
21	OUT.2	R	71		R/W
22	HOUT.2	R	72		R/W
23	COUT.2	R	73		R/W
24	MOD.2	R	74		R/W
25	PIDNO.2	R	75		R/W
26	DEV.1	R	76		R/W
27	OR.1	R	77		R/W
28			78		R/W
29			79		R/W
30	DEV.2	R	80		R/W
31	OR.2	R	81		R/W
32	SMEC	R	82		R/W
33	DISTS	R	83		R/W
34	RDISTS	R	84		R/W
35	PARAERR	R	85		R/W
36	ALOSTS	R	86		R/W
37			87		R/W
38			88		R/W
39	DISP1	R	89		R/W
40	DISP2	R	90		R/W
41	TIME	R	91		R/W
42	PTNO	R	92		R/W
43	SEGNO	R	93		R/W
44	SEGUSE	R	94		R/W
45	REM.RCY	R	95		R/W
46	ALL.RCY	R	96		R/W
47	RST	R	97		R/W
48	REN	R	98		R/W
49	PVEOSTS	R	99		R/W
50		R/W	100		R/W

 : User area (You cannot use these registers when a graphic panel is used.)

050401E.EPS

### 5.4.1 Process Data Area (Read-only Data)

Some of the registers in this area (D0001 to D0049, read-only) are designed to represent two or more events, such as errors and statuses, using combinations of bits within the register. If any of the events shown in the following tables occurs, the corresponding bit is set to 1. The bit remains 0 when the event has not occurred. Note that bits with blank fields in the tables are not in use.

#### TIP

Each bit in the following tables is the same, in terms of the code and the type of event, as that for each I relay listed in Section 5.11, "Status Area," to Section 5.14, "Alarm Flag, Timer Flag, Power-on Flag Status Area."

#### ● Bit Configuration of D0001: ADERROR (Input Error)

Bit	Code	Event	I Relay No.
0	AD1ERR.st	Input 1 A/D converter error	1
1	AD2ERR.st	Input 2 A/D converter error	2
2	AD3ERR.st	Input 3 A/D converter error	3
3			4
4	AD1BO.st	Input 1 burnout error	5
5	AD2BO.st	Input 2 burnout error	6
6	AD3BO.st	Input 3 burnout error	7
7			8
8	RJC1ERR.st	Input 1 RJC error	9
9	RJC2ERR.st	Input 2 RJC error	10
10 to 15			11 to 15

050402E.EPS

#### ● Bit Configuration of D0002: ERROR.1 (PV1 Error)

Bit	Code	Event	I Relay No.
0	PV1ADC.st	PV1 A/D converter error	17
1	PV1BO.st	PV1 burnout error	18
2	RJC1ERR.st	PV1 RJC error	19
3			20
4	PV1+over.st	PV1 overscale	21
5	PV1-over.st	PV1 underscale	22
6 to 13			23 to 30
14	AT1ERR.st	Auto-tuning error	31
15			32

050403E.EPS

● **D0003: PV.1 (Measured input value [PV] for Loop 1)**

● **D0004: CSP.1 (Current target setpoint [SP] for Loop 1)**

● **D0005: OUT.1 (Control output value [OUT] for Loop 1)**

- With PID control, you can read the computation result as is from this register. For example, when the computation result is 75.0%, the register contains a value of “750” (data without the decimal point).
- With on-off control, the register contains “0” (0.0%) for the OFF state or “1000” (100.0%) for the ON state (data without the decimal point).
- With heating/cooling control, this register contains a value half the PID computation result.

● **D0006: HOUT.1 (Heating-side control output for Loop 1 in Heating/Cooling Control)**

- With on-off control, this register contains 0 (0.0%) for the OFF state or 1000 (100.0%) for the ON state.
- With heating/cooling control, this register contains the heating-side control output value.

● **D0007: COUT.1 (Cooling-side control output for Loop 1 in Heating/Cooling Control)**

- With on-off control, this register contains 0 (0.0%) for the OFF state or 1000 (100.0%) for the ON state.
- With heating/cooling control, this register contains the cooling-side control output value.

● **Bit Configuration of D0008: MOD.1 (Operation mode of Loop 1)**

Bit	Code	Event	I Relay No.
0	A/M1.st	0: AUTO; 1: MAN	65
1 to 7			66 to 72
8	RESET.st	1: Program reset	73
9	PROG.st	1: Program operation	74
10	LOCAL.st	1: Local operation	75
11			76
12	HOLD.st	1: Pause	77
13	WAIT.st	1: Wait	78
14	AT1.st	0: Auto-tuning is OFF; 1: Auto-tuning is ON	79
15			80

050404E.EPS

● **D0009: PIDNO.1 (Current PID number for Loop 1)**

From this register, you can read the PID number currently in use in the form of a binary bit string. For example, the configuration of “bit 3 = off; bit 2 = on; bit 1 = off; bit 0 = on”, which is represented as “0101” in binary notation and as “5” in decimal notation, indicates that the currently used PID number is 5.

Bit	Code	Event	I Relay No.
0	PIDNO.0	Bit 0 of the current PID number	593
1	PIDNO.1	Bit 1 of the current PID number	594
2	PIDNO.2	Bit 2 of the current PID number	595
3	PIDNO.3	Bit 3 of the current PID number	596
4 to 15			597 to 608

050405E.EPS

● **Bit Configuration of D0011: ALM (Alarm Status)**

Bit	Code	Event	I Relay No.
0	ALM11.st	'1' when alarm 1 1 is ON; '0' when OFF	97
1	ALM12.st	'1' when alarm 2 1 is ON; '0' when OFF	98
2	ALM13.st	'1' when alarm 3 1 is ON; '0' when OFF	99
3			100
4	ALM14.st	'1' when alarm 4 1 is ON; '0' when OFF	101
5	OR1.st	'1' when sensor grounding alarm for Loop 1 is ON; '0' when OFF	102
6 to 12			103 to 110
13	OR2.st	'1' when sensor grounding alarm for Loop 2 is ON; '0' when OFF	110
14, 15			111, 112

050406E.EPS

● **Bit Configuration of D0012: PVEV (PV Event Status)**

Bit	Code	Event	I Relay No.
0	PVE1.st	'1' when PV event 1 is ON; '0' when OFF	113
1	PVE2.st	'1' when PV event 2 is ON; '0' when OFF	114
2	PVE3.st	'1' when PV event 3 is ON; '0' when OFF	115
3			116
4	PVE4.st	'1' when PV event 4 is ON; '0' when OFF	117
5	PVE5.st	'1' when PV event 5 is ON; '0' when OFF	118
6	PVE6.st	'1' when PV event 6 is ON; '0' when OFF	119
7			200
8	PVE7.st	'1' when PV event 7 is ON; '0' when OFF	201
9	PVE8.st	'1' when PV event 8 is ON; '0' when OFF	202
10 to 15			203 to 128

050407E.EPS

● Bit Configuration of D0013: TMEV1 (Time Event Status)

Bit	Code	Event	I Relay No.
0	TME1.st	'1' when time event 1 is ON; '0' when OFF	129
1	TME2.st	'1' when time event 2 is ON; '0' when OFF	130
2	TME3.st	'1' when time event 3 is ON; '0' when OFF	131
3			132
4	TME4.st	'1' when time event 4 is ON; '0' when OFF	133
5	TME5.st	'1' when time event 5 is ON; '0' when OFF	134
6	TME6.st	'1' when time event 6 is ON; '0' when OFF	135
7			136
8	TME7.st	'1' when time event 7 is ON; '0' when OFF	137
9	TME8.st	'1' when time event 8 is ON; '0' when OFF	138
10 to 15			139 to 145

050408E.EPS

● Bit Configuration of D0014: TMEV2 (Time Event Status)

Continued from D0013 (Time event status).

Bit	Code	Event	I Relay No.
0	TME9.st	'1' when time event 9 is ON; '0' when OFF	145
1	TME10.st	'1' when time event 10 is ON; '0' when OFF	146
2	TME11st	'1' when time event 11 is ON; '0' when OFF	147
3			148
4	TME12.st	'1' when time event 12 is ON; '0' when OFF	149
5	TME13.st	'1' when time event 13 is ON; '0' when OFF	150
6	TME14.st	'1' when time event 14 is ON; '0' when OFF	151
7			152
8	TME15.st	'1' when time event 15 is ON; '0' when OFF	153
9	TME16.st	'1' when time event 16 is ON; '0' when OFF	154
10	WEND.st	'1' for 1 second after wait state ends.	155
11			156
12	PTEND.st	'1' for 1 second after program pattern ends.	157
13	PTEND3.st	'1' for 3 seconds after program pattern ends.	158
14	PTEND5.st	'1' for 5 seconds after program pattern ends.	159
15			160

050409E.EPS

● D0015: PTN (Program pattern number currently selected for operation)

● D0016: SEGNO (Current segment number)

● D0017: TIME (Remaining time of the current segment, or elapsed time during wait state)



● **Bit Configuration of D0018: ERROR.2 (PV2 Error)**

Bit	Code	Event	I Relay No.
0	PV2ADC.st	PV2 A/D converter error	33
1	PV2BO.st	PV2 burnout error	34
2	RJC2ERR.st	PV2 RJC error	35
3			36
4	PV2+over.st	PV2 overscale	37
5	PV2-over.st	PV2 underscale	38
6 to 13			39 to 46
14	AT2ERR.st	Auto-tuning error	47
15			48

050410E.EPS

● **D0019: PV.2 (Measured input value [PV] for Loop 2)**

● **D0020: CSP.2 (Current target setpoint [SP] for Loop 2)**

● **D0021: OUT.2 (Control output value [OUT] for Loop 2)**

- With PID control, you can read the computation result as is from this register. For example, when the controlresult is 75.0%, the register contains a value of “750” (data without the decimal point).
- With on-off control, the register contains “0” (0.0%) for the OFF state or “1000” (100.0%) for the ON state (data without the decimal point).
- With heating/cooling control, this register contains a value half the PID computation result.

● **D0022: HOUT.2 (Heating-side control output for Loop 2 in Heating/Cooling Control)**

- With on-off control, this register contains 0 (0.0%) for the OFF state or 1000 (100.0%) for the ON state (data without the decimal point).
- With heating/cooling control, this register contains the heating-side control output value.

● **D0023: COUT.2 (Cooling-side control output for Loop 2 in Heating/Cooling Control)**

- With on-off control, this register contains 0 (0.0%) for the OFF state or 1000 (100.0%) for the ON state (data without the decimal point).
- With heating/cooling control, this register contains the cooling-side control output value.

● **Bit Configuration of D0024: MOD.2 (Operation mode of Loop 2)**

Bit	Code	Event	I Relay No.
0	A/M2.st	0: AUTO; 1: MAN	81
1 to 7			81 to 87
8	CAS/LSP.st	0: CAS (cascade); 1: LSP (local)	88
9 to 13			89 to 94
14	AT2.st	0: Auto-tuning is OFF; 1: Auto-tuning is ON	95
15			96

050411E.EPS

● **D0025: PIDNO.2 (Current PID number for Loop 2)**

From this register, you can read the PID number currently in use in the form of a binary bit string. For example, the configuration of “bit 3 = off; bit 2 = on; bit 1 = off; bit 0 = on”, which is represented as “0101” in binary notation and as “5” in decimal notation, indicates that the number of the PID currently being used is 5.

Bit	Code	Event	I Relay No.
0	PIDNO2.0	Bit 0 of the current PID number	609
1	PIDNO2.1	Bit 1 of the current PID number	610
2	PIDNO2.2	Bit 2 of the current PID number	611
3	PIDNO2.3	Bit 3 of the current PID number	612
4 to 15			613 to 624

050412E.EPS

● **D0026: DEV.1 (Deviation for Loop 1)**

● **D0027: OR.1 (Moving average of sensor grounding alarm for Loop 1)**

● **D0030: DEV.2 (Deviation for Loop 2)**

● **D0031: OR.2 (Moving average of sensor grounding alarm for Loop 2)**

● **D0032: SMEC (Sampling period error counter)**

## ● Bit Configuration of D0033: DISTs (Statuses of External Contact Inputs)

Bit	Code	Event	I Relay No.
0	DI1.st	Status of external contact input terminal 1 (1: contact is ON; 0: contact is OFF)	161
1	DI2.st	Status of external contact input terminal 2 (1: contact is ON; 0: contact is OFF)	162
2	DI3.st	Status of external contact input terminal 3 (1: contact is ON; 0: contact is OFF)	163
3	DI4.st	Status of external contact input terminal 4 (1: contact is ON; 0: contact is OFF)	164
4	DI5.st	Status of external contact input terminal 5 (1: contact is ON; 0: contact is OFF)	165
5	DI6.st	Status of external contact input terminal 6 (1: contact is ON; 0: contact is OFF)	166
6	DI7.st	Status of external contact input terminal 7 (1: contact is ON; 0: contact is OFF)	167
7			168
8	DP1	Status of operating display selection 1 (1: displayed; 0: not displayed) <b>[See Also]</b> Section 6.3, "Setting Operating Display Switching Conditions" for information about the operating display function.	169
9	DP2	Status of operating display selection 2 (1: displayed; 0: not displayed)	170
10	MG1	Status of interruptive message 1 (1: displayed; 0: not displayed)	171
11	MG2	Status of interruptive message 2 (1: displayed; 0: not displayed)	172
12	MG3	Status of interruptive message 3 (1: displayed; 0: not displayed)	173
13	MG4	Status of interruptive message 4 (1: displayed; 0: not displayed)	174
14, 15			175, 176

050413E.EPS

Functions assigned to external contact inputs vary depending on the setting of the controller mode (UP mode) and whether or not functions have been assigned to the contact inputs.

### See Also

UP750 User's Manual for Single-loop Control (IM 05E01B02-01E to -07E), for the function assignments of external contact inputs.

● **Bit Configuration of D0034: RDISTS (Statuses of I/O expansion module's contact inputs)**

Bit	Code	Event	I Relay No.
0	RDI101.st	Input terminal 1 status of expansion module 1 (1 contact is ON; 0: contact is OFF)	177
1	RDI102.st	Input terminal 2 status of expansion module 1 (1 contact is ON; 0: contact is OFF)	178
2	RDI103.st	Input terminal 3 status of expansion module 1 (1 contact is ON; 0: contact is OFF)	179
3	RDI104.st	Input terminal 4 status of expansion module 1 (1 contact is ON; 0: contact is OFF)	180
4	RDI105.st	Input terminal 5 status of expansion module 1 (1 contact is ON; 0: contact is OFF)	181
5	RDI106.st	Input terminal 6 status of expansion module 1 (1 contact is ON; 0: contact is OFF)	182
6	RDI107.st	Input terminal 7 status of expansion module 1 (1 contact is ON; 0: contact is OFF)	183
7	RDI108.st	Input terminal 8 status of expansion module 1 (1 contact is ON; 0: contact is OFF)	184
8	RDI201.st	Input terminal 1 status of expansion module 2 (1 contact is ON; 0: contact is OFF)	185
9	RDI202.st	Input terminal 2 status of expansion module 2 (1 contact is ON; 0: contact is OFF)	186
10	RDI203.st	Input terminal 3 status of expansion module 2 (1 contact is ON; 0: contact is OFF)	187
11	RDI204.st	Input terminal 4 status of expansion module 2 (1 contact is ON; 0: contact is OFF)	188
12	RDI205.st	Input terminal 5 status of expansion module 2 (1 contact is ON; 0: contact is OFF)	189
13	RDI206.st	Input terminal 6 status of expansion module 2 (1 contact is ON; 0: contact is OFF)	190
14	RDI207.st	Input terminal 7 status of expansion module 2 (1 contact is ON; 0: contact is OFF)	191
15	RDI208.st	Input terminal 8 status of expansion module 2 (1 contact is ON; 0: contact is OFF)	192

050414E.EPS

Initially, no function is assigned to the contact inputs via an expansion module. Statuses of these contact inputs can be read only after functions are assigned to them.

**See Also**

UP750 User's Manual for Single-loop Control (IM 05E01B02-01E to -07E), for function assignment of external contact inputs via an expansion module.

● **Bit Configuration of D0035: PARAERR (Error in calibration values and parameters)**

Bit	Code	Event	I Relay No.
0	CALB.E.st	Calibration value error	49
1			50
2	USER.E.st	Error in the data set using the custom computation building tool	51
3			52
4	UTMD.st	Controller mode error	53
5	RANGE.st	Input range data error	54
6	SETUP.st	Setup parameter error	55
7			56
8	PARA.E.st	Operation parameter error	57
9	MODE.E.st	Error in power-failure backup data	58
10	FILE.E.st	Program pattern error	59
11 to 13			60 to 62
14	SYSTEM.E.st	System data error	63
15			64

050415E.EPS

● **Bit Configuration of D0036: ALOSTS (Status of alarm output)**

Bit	Code	Event	I Relay No.
0	ALO11	Status of output assigned with alarm 1 0: alarm is OFF for “energized” type alarm or ON for “deenergized” type alarm (the relay contact is open) 1: alarm is ON for “energized” type alarm or OFF for “deenergized” type alarm (the relay contact is closed)	689
1	ALO12	Status of output assigned with alarm 2 Bit status information is the same as bit 0.	690
2	ALO13	Status of output assigned with alarm 3 Bit status information is the same as bit 0.	691
3			692
4	ALO14	Status of output assigned with alarm 4 Bit status information is the same as bit 0.	693
5 to 15			694 to 704

050416E.EPS

● **D0039: DISP1 (Display data value for DISP1 module registered using the Custom Computation Building Tool)**

This register stores a value fed to input 1 (IN1) of the Data Display 1 (DISP1) module.

● **D0040: DISP2 (Display data value for DISP2 module registered using the Custom Computation Building Tool)**

This register stores a value fed to input 1 (IN1) of the Data Display 2 (DISP2) module.

● **D0041: TIME (Remaining time of the current segment, or elapsed time during wait status) Same as D0017**

● **D0042: PTNO (Program pattern number currently selected for operation)**

● **D0043: SEGNO (Current segment number)**

● **D0044: SEGUSE (Number of segments contained in the selected pattern)**

● **D0045: REM.RCY (Number of repetitions of the pattern in operation)**

● **D0046: ALL.RCY (Remaining number of repetitions of the pattern in operation)**

● **D0047: RST (Start-of-repetition segment number)**

● **D0048: REN (End-of-repetition segment number)**

● Bit Configuration of D0049: PVEOSTS (Status of PV event outputs)

Bit	Code	Event	I Relay No.
0	PVEO1.st	Status of output assigned with PV event 1 0: event is OFF when “energized” type is selected, or ON when “deenergized” type is selected (the relay contact is open) 1: event is ON when “energized” type is selected, or OFF when “deenergized” type is selected (the relay contact is closed)	705
1	PVEO2.st	Status of output assigned with PV event 2 Bit status information is the same as bit 0.	706
2	PVEO3.st	Status of output assigned with PV event 3 Bit status information is the same as bit 0.	707
3			708
4	PVEO4.st	Status of output assigned with PV event 4 Bit status information is the same as bit 0.	709
5 to 7			710 to 712
8	PVEO5.st	Status of output assigned with PV event 5 Bit status information is the same as bit 0.	713
9	PVEO6.st	Status of output assigned with PV event 6 Bit status information is the same as bit 0.	714
10	PVEO7.st	Status of output assigned with PV event 7 Bit status information is the same as bit 0.	715
11			716
12	PVEO8.st	Status of output assigned with PV event 8 Bit status information is the same as bit 0.	717
13 to 15			718 to 720

050417E.EPS

### 5.4.2 User Area

Register No.	Category	Description
50 to 100	User area	You can read/write data from/to the D0050 to D0100 registers. However, when a graphic panel is used in the system, you cannot use this area because it is reserved for communication with the graphic panel. When a graphic panel is not used, you are free to use this area without affecting the control function of the UP750.

050418E.EPS

# 5.5 Area for Operation Program data (D Registers 101 to 200)

## ■ Data Storage Area Map

Area for Operation Program data					
No.	Register name	R/W	No.	Register name	R/W
101	LSP1	R/W	151		
102	LSP2	R/W	152		
103	PIDNO	R/W	153		
104	EV21A	R/W	154		
105	EV21B	R/W	155		
106	EV22A	R/W	156		
107	EV22B	R/W	157		
108	EV23A	R/W	158		
109	EV23B	R/W	159		
110	EV24A	R/W	160		
111	EV24B	R/W	161		
112	EV25A	R/W	162		
113	EV25B	R/W	163		
114	EV26A	R/W	164		
115	EV26B	R/W	165		
116	EV27A	R/W	166		
117	EV27B	R/W	167		
118	EV28A	R/W	168		
119	EV28B	R/W	169		
120			170		
121			171		
122			172		
123			173		
124			174		
125			175		
126			176		
127			177		
128			178		
129			179		
130			180		
131			181		
132			182		
133			183		
134			184		
135			185		
136			186		
137			187		
138			188		
139			189		
140			190		
141			191		
142			192		
143			193		
144			194		
145			195		
146			196		
147			197		
148			198		
149			199		
150			200		

050501E.EPS

### 5.5.1 Program Data Area

Register No.	Category	Description	Remarks
101 to 0119	Program data	LSP1: Loop 1 setpoint for local operation LSP2: Loop 2 setpoint for local operation PIDNO: PID group number for local operation EV21A: Local event 21 type EV21B: Local event 21 setpoint EV22A: Local event 22 type EV22B: Local event 22 setpoint EV23A: Local event 23 type EV23B: Local event 23 setpoint EV24A: Local event 24 type EV24B: Local event 24 setpoint EV25A: Local event 25 type EV25B: Local event 25 setpoint EV26A: Local event 26 type EV26B: Local event 26 setpoint EV27A: Local event 27 type EV27B: Local event 27 setpoint EV28A: Local event 28 type EV28B: Local event 28 setpoint	

050502E.EPS



## 5.6 Operation Mode and Computation Parameters (D Registers 201 to 300)

### ■ Data Storage Area Map

Area for Operation Mode and Computation Parameters					
No.	Register name	R/W	No.	Register name	R/W
201			251	ORH.1	R/W
202			252	ORL.1	R/W
203			253	S.TM	R/W
204			254		
205			255		
206			256		
207			257		
208	R/P/L	R/W	258		
209	HOLD	R/W	259		
210	ADV	R/W	260		
211	A/M.1	R/W	261		
212	A/M.2	R/W	262		
213	LSP/CAS	R/W	263		
214	PTNO	R/W	264		
215			265		
216			266		
217	MOUT.1	R/W	267		
218	MOUTc.1	R/W	268		
219	MOUT.2	R/W	269		
220	MOUTc.2	R/W	270		
221	HOLDSP.1	R/W	271	AT.2	R/W
222	HOLDSP.2	R/W	272	SC.2	R/W
223	HOLDTM	R/W	273	BS.2	R/W
224	SST	R/W	274	FL.2	R/W
225			275		
226			276		
227			277		
228			278		
229			279		
230			280	ORB.2	R/W
231	A1	R/W	281	ORH.2	R/W
232	A2	R/W	282	ORL.2	R/W
233	A3	R/W	283		
234	A4	R/W	284		
235			285		
236			286		
237			287		
238			288		
239			289		
240			290		
241	AT.1	R/W	291		
242	SC.1	R/W	292		
243	BS.1	R/W	293		
244	FL.1	R/W	294		
245			295		
246			296		
247			297		
248			298		
249			299		
250	ORB.1	R/W	300		

050601E.EPS

## 5.6.1 Operation Mode Information

The mode registers listed below are designed to show, by the value contained, which mode is selected. You can also change the mode by writing a different mode into the register via communication.

### ● D0208: R/P/L (Program reset/Program modes)

When D0208 = 0, program operation is reset.

When D0208 = 1, program operation.

When D0208 = 2, local operation.

### ● D0209: HOLD (HOLD state of program operation)

When D0209 = 0, program operation is in progress.

When D0209 = 1, program operation is paused.

### ● D0210: ADV (Forced segment advance)

When D0210 = 0, segment has either advanced or has not advanced yet.

When D0210 = 1, advance one segment.

### ● D0211: A/M1 (AUTO/MAN modes for Loop-1)

When D0211 = 0, Loop 1 is in the AUTO mode.

When D0211 = 1, Loop 1 is in the MAN mode.

### ● D0212: A/M2 (AUTO/MAN modes for Loop-2)

When D0212 = 0, Loop 2 is in the AUTO mode.

When D0212 = 1, Loop 2 is in the MAN mode.

### ● D0213: LSP/CAS (LSP/CAS modes)

When D0213 = 0, the controller is in the CAS (cascade) mode.

When D0213 = 1, the controller is in the LSP (local) mode.

## 5.6.2 Write-only Data Area

The registers listed below are write-only registers that are accessed by a higher-level device.

Register No.	Code	Description
D0217	MOUT.1	Used to set control output value or heating-side control output value when Loop 1 is in the MAN mode.
D0218	MOUTc.1	Used to set cooling-side control output value when Loop 1 is in the MAN mode.
D0219	MOUT.2	Used to set control output value or heating side control output value when Loop 2 is in the MAN mode.
D0220	MOUTc.2	Used to set cooling-side control output value when Loop 2 is in the MAN mode.
D0221	HOLDSP.1	Used to set Loop 1 SP in HOLD state.
D0222	HOLDSP.2	Used to set Loop 2 SP in HOLD state.
D0223	HOLDTM	Used to set HOLD time.
D0224	SST	Used to set the segment number from which the program operation starts.

050602E.EPS

### 5.6.3 Data Area for Computation Parameters

Register No.	Category	Description	Remarks
231 to 234	Instrument alarm setpoints	A1 to A4: Setpoint for instrument alarm 1 to 4	
241 to 252	Loop 1 computation parameters	AT.1: Loop 1 auto-tuning selection SC.1: Loop 1 SUPER function selection BS.1: Loop 1 PV bias FL.1: Loop 1 PV filter UPR.1: Loop 1 setpoint ramp-up rate DNR.1: Loop 1 setpoint ramp-down rate RT.1: Loop 1 ratio setting RBS.1: Loop 1 remote bias RFL.1: Loop 1 remote input filter ORB.1: Loop 1 ON/OFF rate detection range ORH.1: Loop 1 ON/OFF rate high limit ORL.1: Loop 1 ON/OFF rate low limit	
271 to 282	Loop 2 computation parameters	The Loop 2 computation parameters, i.e., AT.2 through ORL.2, are functionally the same as their corresponding Loop 1 computation parameters.	

050603E.EPS

● **D0253: S.TM (Start time of program pattern operation)**

00.00 to 99.59 (hh.mm or mm.ss)

# 5.7 Loop 1 PID Parameters (D Registers 301 to 500)

## ■ Data Storage Area Map

Area for Loop-1 PID Parameters											
No.	Register name	R/W	No.	Register name	R/W	No.	Register name	R/W	No.	Register name	R/W
301			351			401			451		
302			352			402			452		
303			353			403			453		
304			354			404			454		
305			355			405			455		
306	1.P	R/W	356	3.P	R/W	406	5.P	R/W	456	7.P	R/W
307	1.I	R/W	357	3.I	R/W	407	5.I	R/W	457	7.I	R/W
308	1.D	R/W	358	3.D	R/W	408	5.D	R/W	458	7.D	R/W
309	1.OH	R/W	359	3.OH	R/W	409	5.OH	R/W	459	7.OH	R/W
310	1.OL	R/W	360	3.OL	R/W	410	5.OL	R/W	460	7.OL	R/W
311	1.MR	R/W	361	3.MR	R/W	411	5.MR	R/W	461	7.MR	R/W
312	1.H	R/W	362	3.H	R/W	412	5.H	R/W	462	7.H	R/W
313	1.DR	R/W	363	3.DR	R/W	413	5.DR	R/W	463	7.DR	R/W
314	1.Pc	R/W	364	3.Pc	R/W	414	5.Pc	R/W	464	7.Pc	R/W
315	1.Ic	R/W	365	3.Ic	R/W	415	5.Ic	R/W	465	7.Ic	R/W
316	1.Dc	R/W	366	3.Dc	R/W	416	5.Dc	R/W	466	7.Dc	R/W
317	1.Hc	R/W	367	3.Hc	R/W	417	5.Hc	R/W	467	7.Hc	R/W
318	1.DB	R/W	368	3.DB	R/W	418	5.DB	R/W	468	7.DB	R/W
319	1.RP	R/W	369	3.RP	R/W	419	5.RP	R/W	469	RHY	R/W
320	1.PO	R/W	370	3.PO	R/W	420	5.PO	R/W	470	7.PO	R/W
321	1.Oc	R/W	371	3.Oc	R/W	421	5.Oc	R/W	471	7.Oc	R/W
322			372			422			472		
323			373			423			473		
324			374			424			474		
325			375			425			475		
326			376			426			476		
327			377			427			477		
328			378			428			478		
329			379			429			479		
330			380			430			480		
331	2.P	R/W	381	4.P	R/W	431	6.P	R/W	481	8.P	R/W
332	2.I	R/W	382	4.I	R/W	432	6.I	R/W	482	8.I	R/W
333	2.D	R/W	383	4.D	R/W	433	6.D	R/W	483	8.D	R/W
334	2.OH	R/W	384	4.OH	R/W	434	6.OH	R/W	484	8.OH	R/W
335	2.OL	R/W	385	4.OL	R/W	435	6.OL	R/W	485	8.OL	R/W
336	2.MR	R/W	386	4.MR	R/W	436	6.MR	R/W	486	8.MR	R/W
337	2.H	R/W	387	4.H	R/W	437	6.H	R/W	487	8.H	R/W
338	2.DR	R/W	388	4.DR	R/W	438	6.DR	R/W	488	8.DR	R/W
339	2.Pc	R/W	389	4.Pc	R/W	439	6.Pc	R/W	489	8.Pc	R/W
340	2.Ic	R/W	390	4.Ic	R/W	440	6.Ic	R/W	490	8.Ic	R/W
341	2.Dc	R/W	391	4.Dc	R/W	441	6.Dc	R/W	491	8.Dc	R/W
342	2.Hc	R/W	392	4.Hc	*R/W	442	6.Hc	R/W	492	8.Hc	R/W
343	2.DB	R/W	393	4.DB	R/W	443	6.DB	R/W	493	8.DB	R/W
344	2.RP	R/W	394	4.RP	R/W	444	6.RP	R/W	494	RDV	R/W
345	2.PO	R/W	395	4.PO	R/W	445	6.PO	R/W	495	8.PO	R/W
346	2.Oc	R/W	396	4.Oc	R/W	446	6.Oc	R/W	496	8.Oc	R/W
347			397			447			497		
348			398			448			498		
349			399			449			499		
350			400			450			500		

050701E.EPS

## 5.7.1 Data Area for Loop 1 PID Parameters

Register No.	Category	Description	Remarks
306 to 321	Group 1 parameters for Loop 1	1.P: Proportional band 1.I: Integral time 1.D: Derivative time 1.OH: Upper limit of output 1.OL: Lower limit of output 1.MR: Manual reset 1.H: Hysteresis 1.DR: Direct/reverse action switchover 1.Pc: Cooling-side proportional band 1.Ic: Cooling-side integral time 1.Dc: Cooling-side derivative time 1.Hc: Cooling-side relay hysteresis 1.DB: Deadband 1.RP: Zone PID reference point 1.PO: Preset output value 1.Oc: Cooling-side preset output value	When zone PID switching is selected, the groups that correspond to the respective zones will be used.  When segment PID switching is selected, the group specified for each segment (or the group specified in local operation) will be used.
331 to 346	Group 2 parameters for Loop 1	The parameters from 2.P to 2.Oc are functionally the same as their corresponding group 1 parameters.	
356 to 371	Group 3 parameters for Loop 1	The parameters from 3.P to 3.Oc are functionally the same as their corresponding group 1 parameters.	
381 to 396	Group 4 parameters for Loop 1	The parameters from 4.P to 4.Oc are functionally the same as their corresponding group 1 parameters.	
406 to 421	Group 5 parameters for Loop 1	The parameters from 5.P to 5.Oc are functionally the same as their corresponding group 1 parameters.	
431 to 446	Group 6 parameters for Loop 1	The parameters from 6.P to 6.Oc are functionally the same as their corresponding group 1 parameters.	
456 to 471	Group 7 parameters for Loop 1	The parameters from 7.P to 7.Oc are functionally the same as their corresponding group 1 parameters. However, parameter RHY, which corresponds to 1.RP, denotes the zone PID hysteresis.	
481 to 496	Group 8 parameters for Loop 1	The parameters from 8.P to 8.Oc are functionally the same as their corresponding group 1 parameters. However, parameter RDV, which corresponds to 1.RP, denotes the zone PID reference deviation.	

050702E.EPS

# 5.8 Loop 2 PID Parameters (D Registers 501 to 700)

## ■ Data Storage Area Map

Area for Loop-2 PID Parameters											
No.	Register name	R/W	No.	Register name	R/W	No.	Register name	R/W	No.	Register name	R/W
501			551			601			651		
502			552			602			652		
503			553			603			653		
504			554			604			654		
505			555			605			655		
506	1.P	R/W	556	3.P	R/W	606	5.P	R/W	656	7.P	R/W
507	1.I	R/W	557	3.I	R/W	607	5.I	R/W	657	7.I	R/W
508	1.D	R/W	558	3.D	R/W	608	5.D	R/W	658	7.D	R/W
509	1.OH	R/W	559	3.OH	R/W	609	5.OH	R/W	659	7.OH	R/W
510	1.OL	R/W	560	3.OL	R/W	610	5.OL	R/W	660	7.OL	R/W
511	1.MR	R/W	561	3.MR	R/W	611	5.MR	R/W	661	7.MR	R/W
512	1.H	R/W	562	3.H	R/W	612	5.H	R/W	662	7.H	R/W
513	1.DR	R/W	563	3.DR	R/W	613	5.DR	R/W	663	7.DR	R/W
514	1.Pc	R/W	564	3.Pc	R/W	614	5.Pc	R/W	664	7.Pc	R/W
515	1.Ic	R/W	565	3.Ic	R/W	615	5.Ic	R/W	665	7.Ic	R/W
516	1.Dc	R/W	566	3.Dc	R/W	616	5.Dc	R/W	666	7.Dc	R/W
517	1.Hc	R/W	567	3.Hc	R/W	617	5.Hc	R/W	667	7.Hc	R/W
518	1.DB	R/W	568	3.DB	R/W	618	5.DB	R/W	668	7.DB	R/W
519	1.RP	R/W	569	3.RP	R/W	619	5.RP	R/W	669	RHY	R/W
520	1.PO	R/W	570	3.PO	R/W	620	5.PO	R/W	670	7.PO	R/W
521	1.Oc	R/W	571	3.Oc	R/W	621	5.Oc	R/W	671	7.Oc	R/W
522			572			622			672		
523			573			623			673		
524			574			624			674		
525			575			625			675		
526			576			626			676		
527			577			627			677		
528			578			628			678		
529			579			629			679		
530			580			630			680		
531	2.P	R/W	581	4.P	R/W	631	6.P	R/W	681	8.P	R/W
532	2.I	R/W	582	4.I	R/W	632	6.I	R/W	682	8.I	R/W
533	2.D	R/W	583	4.D	R/W	633	6.D	R/W	683	8.D	R/W
534	2.OH	R/W	584	4.OH	R/W	634	6.OH	R/W	684	8.OH	R/W
535	2.OL	R/W	585	4.OL	R/W	635	6.OL	R/W	685	8.OL	R/W
536	2.MR	R/W	586	4.MR	R/W	636	6.MR	R/W	686	8.MR	R/W
537	2.H	R/W	587	4.H	R/W	637	6.H	R/W	687	8.H	R/W
538	2.DR	R/W	588	4.DR	R/W	638	6.DR	R/W	688	8.DR	R/W
539	2.Pc	R/W	589	4.Pc	R/W	639	6.Pc	R/W	689	8.Pc	R/W
540	2.Ic	R/W	590	4.Ic	R/W	640	6.Ic	R/W	690	8.Ic	R/W
541	2.Dc	R/W	591	4.Dc	R/W	641	6.Dc	R/W	691	8.Dc	R/W
542	2.Hc	R/W	592	4.Hc	R/W	642	6.Hc	R/W	692	8.Hc	R/W
543	2.DB	R/W	593	4.DB	R/W	643	6.DB	R/W	693	8.DB	R/W
544	2.RP	R/W	594	4.RP	R/W	644	6.RP	R/W	694	RDV	R/W
545	2.PO	R/W	595	4.PO	R/W	645	6.PO	R/W	695	8.PO	R/W
546	2.Oc	R/W	596	4.Oc	R/W	646	6.Oc	R/W	696	8.Oc	R/W
547			597			647			697		
548			598			648			698		
549			599			649			699		
550			600			650			700		

050801E.EPS

## 5.8.1 Data Area for Loop 2 PID Parameters

Register No.	Category	Description	Remarks
506 to 521	Group 1 parameters for Loop 2	1.P: Proportional band 1.I: Integral time 1.D: Derivative time 1.OH: Upper limit of output 1.OL: Lower limit of output 1.MR: Manual reset 1.H: Hysteresis 1.DR: Direct/reverse action switchover 1.Pc: Cooling-side proportional band 1.Ic: Cooling-side integral time 1.Dc: Cooling-side derivative time 1.Hc: Cooling-side relay hysteresis 1.DB: Deadband 1.RP: Zone PID reference point 1.PO: Preset output value 1.Oc: Cooling-side preset output value	When zone PID switching is selected, the groups that correspond to the respective zones will be used.  When segment PID switching is selected, the group specified for each segment (or the group specified in local operation) will be used.
531 to 546	Group 2 parameters for Loop 2	The parameters from 2.P to 2.Oc are functionally the same as their corresponding group 1 parameters.	
556 to 571	Group 3 parameters for Loop 2	The parameters from 3.P to 3.Oc are functionally the same as their corresponding group 1 parameters.	
581 to 596	Group 4 parameters for Loop 2	The parameters from 4.P to 4.Oc are functionally the same as their corresponding group 1 parameters.	
606 to 621	Group 5 parameters for Loop 2	The parameters from 5.P to 5.Oc are functionally the same as their corresponding group 1 parameters.	
631 to 646	Group 6 parameters for Loop 2	The parameters from 6.P to 6.Oc are functionally the same as their corresponding group 1 parameters.	
656 to 671	Group 7 parameters for Loop 2	The parameters from 7.P to 7.Oc are functionally the same as their corresponding group 1 parameters. However, parameter RHY, which corresponds to 1.RP, denotes the zone PID hysteresis.	
681 to 696	Group 8 parameters for Loop 2	The parameters from 8.P to 8.Oc are functionally the same as their corresponding group 1 parameters. However, parameter RDV, which corresponds to 1.RP, denotes the zone PID reference deviation.	

050802E.EPS

# 5.9 USER Parameters, 10-segment Linearizer Parameters, and Messages (D Registers 701 to 900)

## ■ Data Storage Area Map

Area for USER Parameters, Ten-segment Linearizer Parameters, and Messages											
No.	Register name	R/W	No.	Register name	R/W	No.	Register name	R/W	No.	Register name	R/W
701	U1	R/W	751	2.A1	R/W	801	MG10	R/W	851		
702	U2	R/W	752	2.B1	R/W	802	MG11	R/W	852		
703	U3	R/W	753	2.A2	R/W	803	MG12	R/W	853		
704	U4	R/W	754	2.B2	R/W	804	MG13	R/W	854		
705	U5	R/W	755	2.A3	R/W	805	MG14	R/W	855		
706	U6	R/W	756	2.B3	R/W	806	MG15	R/W	856		
707	U7	R/W	757	2.A4	R/W	807	MG16	R/W	857		
708	U8	R/W	758	2.B4	R/W	808	MG17	R/W	858		
709			759	2.A5	R/W	809	MG18	R/W	859		
710			760	2.B5	R/W	810	MG19	R/W	860		
711			761	2.A6	R/W	811	MG20	R/W	861		
712			762	2.B6	R/W	812	MG21	R/W	862		
713			763	2.A7	R/W	813	MG22	R/W	863		
714			764	2.B7	R/W	814	MG23	R/W	864		
715			765	2.A8	R/W	815	MG24	R/W	865		
716			766	2.B8	R/W	816	MG25	R/W	866		
717			767	2.A9	R/W	817	MG26	R/W	867		
718			768	2.B9	R/W	818	MG27	R/W	868		
719			769	2.A10	R/W	819	MG28	R/W	869		
720			770	2.B10	R/W	820	MG29	R/W	870		
721			771	2.A11	R/W	821	MG30	R/W	871		
722			772	2.B11	R/W	822	MG31	R/W	872		
723			773	2.PMD	R/W	823	MG32	R/W	873		
724			774			824	MG33	R/W	874		
725			775			825	MG34	R/W	875		
726	1.A1	R/W	776			826	MG35	R/W	876		
727	1.B1	R/W	777			827	MG36	R/W	877		
728	1.A2	R/W	778			828	MG37	R/W	878		
729	1.B2	R/W	779			829	MG38	R/W	879		
730	1.A3	R/W	780			830	MG39	R/W	880		
731	1.B3	R/W	781			831	MG40	R/W	881		
732	1.A4	R/W	782			832	MG41	R/W	882		
733	1.B4	R/W	783			833	MG42	R/W	883		
734	1.A5	R/W	784			834	MG43	R/W	884		
735	1.B5	R/W	785			835	MG44	R/W	885		
736	1.A6	R/W	786			836	MG45	R/W	886		
737	1.B6	R/W	787			837	MG46	R/W	887		
738	1.A7	R/W	788			838	MG47	R/W	888		
739	1.B7	R/W	789			839	MG48	R/W	889		
740	1.A8	R/W	790			840	MG49	R/W	890		
741	1.B8	R/W	791			841	NAME1	R/W	891		
742	1.A9	R/W	792			842	NAME2	R/W	892		
743	1.B9	R/W	793			843	NAME3	R/W	893		
744	1.A10	R/W	794			844	NAME4	R/W	894		
745	1.B10	R/W	795			845	NAME5	R/W	895		
746	1.A11	R/W	796			846	NAME6	R/W	896		
747	1.B11	R/W	797			847	NAME7	R/W	897		
748	1.PMD	R/W	798			848	NAME8	R/W	898		
749			799			849	NAME9	R/W	899		
750			800			850	NAME10	R/W	900		



## 5.9.1 Data Area for USER Parameters

Register No.	Category	Description	Remarks
701 to 708	USER parameter	U1 to U8	Parameters U1 to U3 are used when the controller mode (UT mode) is set for loop control with PV switching, loop control with PV auto-selector, loop control with PV switching and two universal inputs, or loop control with PV auto-selector and two universal inputs. Parameters U4 to U8 are used when the controller is set up for custom computation control.

050902E.EPS

## 5.9.2 Data Area for Parameters of 10-segment Linearizers 1 and 2

Register No.	Category	Description	Remarks
726 to 748	Ten-segment linearizer 1 parameters	1.A1: 10-segment linearizer 1 input 1 1.B1: 10-segment linearizer 1 output 1 1.A2: 10-segment linearizer 1 input 2 1.B2: 10-segment linearizer 1 output 2 1.A3: 10-segment linearizer 1 input 3 1.B3: 10-segment linearizer 1 output 3 1.A4: 10-segment linearizer 1 input 4 1.B4: 10-segment linearizer 1 output 4 1.A5: 10-segment linearizer 1 input 5 1.B5: 10-segment linearizer 1 output 5 1.A6: 10-segment linearizer 1 input 6 1.B6: 10-segment linearizer 1 output 6 1.A7: 10-segment linearizer 1 input 7 1.B7: 10-segment linearizer 1 output 7 1.A8: 10-segment linearizer 1 input 8 1.B8: 10-segment linearizer 1 output 8 1.A9: 10-segment linearizer 1 input 9 1.B9: 10-segment linearizer 1 output 9 1.A10: 10-segment linearizer 1 input 10 1.B10: 10-segment linearizer 1 output 10 1.A11: 10-segment linearizer 1 input 11 1.B11: 10-segment linearizer 1 output 11 1.PMD: 10-segment linearizer 1 mode	1. A1 ≤ 1.A2 ≤ ... ≤ 1.A11 1.B1 ≤ 1.B2 ≤ ... ≤ 1.B11  Unit and setting range EU data: -66.7 through 105.0% of measurement range; EUS data: -66.7 through 105.0% of measurement range span; % data: -5.0 through 105.0%
751 to 773	Ten-segment linearizer 2 parameters	The parameters from 2.A1 to 2.PMD are functionally the same as their corresponding parameters for 10-segment linearizer 1	

050903E.EPS

## 5.9.3 Area for Setting Message Text

Register No.	Category	Code	Remarks
801 to 810	Message 1 text setting	MG10 to MG19	These registers store the user-defined messages registered using the LL100 PC-based Parameters Setting Tool. Each message text should include no more than 20 alphanumeric characters. You can register a maximum of four messages.
811 to 820	Message 2 text setting	MG20 to MG29	
821 to 830	Message 3 text setting	MG30 to MG39	
831 to 840	Message 4 text setting	MG40 to MG49	
841 to 850	Instrument name	NAME1 to NAME10	Instrument name should include no more than 20 alphanumeric characters.

050904E.EPS

**Message (MG)** To display a message on the LCD display of the controller, do the following.

- (1) Assign the interruptive message display function to a contact input.
- (2) Register a message using LL100 PC-based Parameters Setting Tool.
- (3) Turn on the contact input.

**Name (NAME)** The characters entered to the name area will not be shown on the controller. This name is used as a tag name, instrument name, or other.

# 5.10 Control Action, Loop-common Function, and I/O Configuration Parameters (D Registers 901 to 1200)

## ■ Data Storage Area Map

Area for Control Action, Loop-common Function, and I/O Configuration Parameters																	
No.	Register name	R/W	No.	Register name	R/W	No.	Register name	R/W	No.	Register name	R/W	No.	Register name	R/W	No.	Register name	R/W
901			951			1001	A.BS1	R/W	1051	LDATA1L	R/W	1101	C.S1	R/W	1151	ADV	R/W
902	SPT.1	R/W	952			1002	A.FL1	R/W	1052	LDATA1H	R/W	1102	C.S2	R/W	1152	A/M.1	R/W
903			953			1003	A.SR1	R/W	1053	LDATA2L	R/W	1103	C.S3	R/W	1153	A/M.2	R/W
904	TMU.1	R/W	954			1004	A.LC1	R/W	1054	LDATA2H	R/W	1104	C.S4	R/W	1154	LSP/CAS	R/W
905	SEG.T	R/W	955			1005	A.BS2	R/W	1055	LDATA3L	R/W	1105	C.S5	R/W	1155	PTNO.b0	R/W
906	PT2.G	R/W	956			1006	A.FL2	R/W	1056	LDATA3H	R/W	1106	DO1	R/W	1156	PTNO.b1	R/W
907	EHY1	R/W	957			1007	A.SR2	R/W	1057	LDATA4L	R/W	1107	DO2	R/W	1157	PTNO.b2	R/W
908	EHY2	R/W	958			1008	A.LC2	R/W	1058	LDATA4H	R/W	1108	DO3	R/W	1158	PTNO.b3	R/W
909	EHY3	R/W	959			1009	A.BS3	R/W	1059	LDATA5L	R/W	1109	DO4	R/W	1159	PTNO.b4	R/W
910	EHY4	R/W	960			1010	A.FL3	R/W	1060	LDATA5H	R/W	1110	DO5	R/W	1160	PTNO.b5	R/W
911	EHY5	R/W	961			1011	A.SR3	R/W	1061			1111	DO6	R/W	1161	PTNO.b6	R/W
912	EHY6	R/W	962			1012	A.LC3	R/W	1062			1112	DO7	R/W	1162	PTNO.b7	R/W
913	EHY7	R/W	963			1013	RET1	R/W	1063			1113	RDO151	R/W	1163	PTNO.b8	R/W
914	EHY8	R/W	964			1014	RTH1	R/W	1064			1114	RDO152	R/W	1164	DP1	R/W
915	AL1.1	R/W	965			1015	RTL1	R/W	1065			1115	RDO153	R/W	1165	DP2	R/W
916	AL2.1	R/W	966	OPR.2	R/W	1016	RET2	R/W	1066			1116	RDO154	R/W	1166	MG1	R/W
917	AL3.1	R/W	967	MOD.2	R/W	1017	RTH2	R/W	1067			1117	RDO155	R/W	1167	MG2	R/W
918	AL4.1	R/W	968	AR.2	R/W	1018	RTL2	R/W	1068			1118	RDO156	R/W	1168	MG3	R/W
919	HY1.1	R/W	969			1019			1069			1119	RDO157	R/W	1169	MG4	R/W
920	HY2.1	R/W	970			1020			1070			1120	RDO158	R/W	1170	PYA1	R/W
921	HY3.1	R/W	971			1021	TSC1	R/W	1071			1121	RDO251	R/W	1171	PYB1	R/W
922	HY4.1	R/W	972			1022	TSC2	R/W	1072			1122	RDO252	R/W	1172	PYA2	R/W
923	AMD.1	R/W	973	SPH.2	R/W	1023	TTM	R/W	1073			1123	RDO253	R/W	1173	PYB2	R/W
924			974	SPL.2	R/W	1024	L-▲▼	R/W	1074			1124	RDO254	R/W	1174		
925			975			1025			1075			1125	RDO255	R/W	1175		
926	OPR.1	R/W	976			1026	PT.NO	R/W	1076			1126	RDO256	R/W	1176		
927	MOD.1	R/W	977			1027	RUN	R/W	1077			1127	RDO257	R/W	1177		
928	AR.1	R/W	978			1028	MODE	R/W	1078			1128	RDO258	R/W	1178		
929	ZON	R/W	979			1029	PRG	R/W	1079			1129			1179		
930	R.MD	R/W	980			1030	LP1	R/W	1080			1130			1180		
931	R.TM	R/W	981			1031	LP2	R/W	1081			1131			1181		
932			982			1032	PID	R/W	1082			1132			1182		
933	SPH.1	R/W	983			1033	USR	R/W	1083			1133			1183		
934	SPL.1	R/W	984			1034	PYS1	R/W	1084			1134			1184		
935			985			1035	PYS2	R/W	1085			1135			1185		
936			986			1036			1086			1136			1186		
937			987			1037			1087			1137			1187		
938			988			1038			1088			1138			1188		
939	PNC	R/W	989			1039			1089			1139			1189		
940	GRP	R/W	990			1040			1090			1140			1190		
941			991			1041	DATA1	R/W	1091			1141			1191		
942			992			1042	DATA2	R/W	1092			1142			1192		
943			993			1043	DATA3	R/W	1093			1143			1193		
944			994			1044	DATA4	R/W	1094			1144			1194		
945			995			1045	DATA5	R/W	1095			1145			1195		
946			996			1046	DATA6	R/W	1096			1146			1196		
947			997			1047	DATA7	R/W	1097			1147	PROG	R/W	1197		
948			998			1048	DATA8	R/W	1098			1148	RESET	R/W	1198		
949			999			1049	DATA9	R/W	1099			1149	LOCAL	R/W	1199		
950			1000			1050	DATA10	R/W	1100			1150	HOLD	R/W	1200		

051001E.EPS

### 5.10.1 Data Area for Control Action Parameters

Register No.	Category	Description	Remarks
902 to 906	SP related parameters	SPT.1 to PT2.G	
907 to 914	Event-related parameters	EHY1 to EHY8	
915 to 923, 940	Instrument alarm setting parameters	AL1.1 to AMD.1	
926 to 931	Control function setting parameters for Loop 1	OPR.1 to R.TM	
933, 934, 939	SP upper and lower limit parameters for Loop 1	SPH.1, SPL.1, PNC	
929 to 931, 966 to 968, 940	Control function setting parameters for Loop 2	ZON to R.TM, OPR.2 to AR.2, GRP	
973, 974, 979	SP upper and lower limit parameters for Loop 2	SPH.2, SPL.2	

051002E.EPS

### 5.10.2 Data Area for Loop-common Function Parameters

Register No.	Category	Description	Remarks
1001 to 1004	Input computation setting parameters	A.BS1 to A.LC1	
1005 to 1008		A.BS2 to A.LC2	
1009 to 1012		A.BS3 to A.LC3	
1013 to 1018	Retransmission output setting parameters	RET1 to RTL2	
1019 to 1023	Deviation trend setting parameters	TSC1 to TTM	
1024 to 1028	Key lock setting parameters	L-▲▼ to MODE	
1029 to 1035	Menu lock setting parameters	PRG to PYS2	

051003E.EPS

### 5.10.3 Data Area for Saving Module Outputs

Register No.	Category	Description	Remarks
1041 to 1050	Module output data saved (word)	DATA1 to DATA10	
1051 to 1060	Module output data saved (long word)	LDATA1L to LDATA5H	

051004E.EPS

### 5.10.4 Data Area for I/O Configuration Parameters

Register No.	Category	Description	Remarks
1101 to 1105	Select display registration parameters	C.S1 to C.S5	
1106 to 1112	Contact output flag configuration parameters	DO1 to DO7	
1113 to 1128	R*** output flag configuration parameters	RDO151 to RDO258	
1147 to 1169	Contact input configuration parameters	PROG to MG4	
1170 to 1173	10-segment linearizer unit setting parameters	PYA1 to PYB2	

051005E.EPS

## 5.11 Controller Mode (UP mode), PV Input, and Control Output Parameters (D Registers 1201 to 1300)

### ■ Data Storage Area Map

Area for controller Mode, Analog Input, and Control Output Parameters					
No.	Register name	R/W	No.	Register name	R/W
1201	IN1	R/W	1251	DLN1	R/W
1202	UNI1	R/W	1252	ADR1	R/W
1203	DP1	R	1253	RP.T1	R/W
1204	RH1	R/W	1254	PSL2	R/W
1205	RL1	R/W	1255	BPS2	R/W
1206	SDP1	R/W	1256	PRI2	R/W
1207	SH1	R/W	1257	STP2	R/W
1208	SL1	R/W	1258	DLN2	R/W
1209	BSL1	R/W	1259	ADR2	R/W
1210	RJC1	R/W	1260	RP.T2	R/W
1211	IN2	R/W	1261		
1212	UNI2	R/W	1262		
1213	DP2	R	1263		
1214	RH2	R/W	1264		
1215	RL2	R/W	1265		
1216	SDP2	R/W	1266	INIT	R/W
1217	SH2	R/W	1267		
1218	SL2	R/W	1268		
1219	BSL2	R/W	1269		
1220	RJC2	R/W	1270		
1221	IN3	R/W	1271		
1222	UNI3	R/W	1272		
1223	DP3	R	1273		
1224	RH3	R/W	1274		
1225	RL3	R/W	1275		
1226	SDP3	R/W	1276		
1227	SH3	R/W	1277		
1228	SL3	R/W	1278		
1229	BSL3	R/W	1279		
1230	P.UNI1	R/W	1280	UTM	R/W
1231	P.DP1	R/W	1281	SMP	R/W
1232	P.RH1	R/W	1282		
1233	P.RL1	R/W	1283		
1234	P.UNI2	R/W	1284		
1235	P.DP2	R/W	1285		
1236	P.RH2	R/W	1286		
1237	P.RL2	R/W	1287		
1238	OT1	R/W	1288		
1239	OT2	R/W	1289		
1240	CT1	R/W	1290		
1241	CT2	R/W	1291		
1242	CTc1	R/W	1292		
1243	CTc2	R/W	1293		
1244	AO1	R/W	1294		
1245	AO2	R/W	1295		
1246	AO3	R/W	1296		
1247	PSL1	R/W	1297		
1248	BPS1	R/W	1298		
1249	PRI1	R/W	1299		
1250	STP1	R/W	1300		

051101E.EPS

### 5.11.1 Data Area for Controller Mode (UP mode), PV Input, and Control Output Parameters

Register No.	Category	Description	Remarks
1201 to 1210	Analog input 1 parameters	IN1 to RJC1	DP1 (D register number 1203) is not a parameter, and this register is read-only.
1211 to 1220	Analog input 2 parameters	IN2 to RJC2	DP2 (D register number 1213) is not a parameter, and this register is read-only.
1221 to 1229	Analog input 3 parameters	IN3 to BSL3	DP3 (D register number 1223) is not a parameter, and this register is read-only.
1230 to 1233	PV input 1 parameters	P.UNI1 to P.RL1	
1234 to 1237	PV input 2 parameters	P.UNI2 to P.RL2	
1238 to 1243	Control output parameters	OT1 to CTc2	
1244 to 1246	RS-485 communication parameters	A01 to A03	
1247 to 1260	Analog output 1to3 types	PSL1 to RP.T2	
1261 to 1265	Valve calibration parameters	V.RS to V.MOD	
1266	Parameter initialization	INIT	
1267	Automatic valve adjustment	V.AT	
1268 to 1273	Analog output scales	A1H to A3L	
1280	Controller mode parameter	UPM	
1281	Control period parameter	SMP	

051102E.EPS

# 5.12 Status Area (I Relays 1 [5001] to 192 [5192])

## ■ Data Storage Area Map

Status Area											
No.	I relay name	No.	I relay name	No.	I relay name	No.	I relay name	No.	I relay name	No.	I relay name
1	AD1ERR.st	33	PV2ADC.st	65	AM1.st	97	ALM11.st	129	TIME1.st	161	DI1.st
2	AD2ERR.st	34	PV2BO.st	66		98	ALM12.st	130	TIME2.st	162	DI2.st
3	AD3ERR.st	35	RJC2ERR.st	67		99	ALM13.st	131	TIME3.st	163	DI3.st
4		36		68		100		132		164	DI4.st
5	AD1BO.st	37	PV2+over.st	69		101	ALM14.st	133	TIME4.st	165	DI5.st
6	AD2BO.st	38	PV2-over.st	70		102	OR1.st	134	TIME5.st	166	DI6.st
7	AD3BO.st	39		71		103		135	TIME6.st	167	DI7.st
8		40		72		104		136		168	
9	RJC1ERR.st	41		73	RESET.st	105		137	TIME7.st	169	DP1.st
10	RJC2ERR.st	42		74	PROG.st	106		138	TIME8.st	170	DP2.st
11		43		75	LOCAL.st	107		139		171	MG1.st
12		44		76		108		140		172	MG2.st
13		45		77	HOLD.st	109		141		173	MG3.st
14		46		78	WAIT.st	110	OR2.st	142		174	MG4.st
15		47	AT2ERR.st	79	AT1.st	111		143		175	
16		48		80		112		144		176	
17	PV1ADC.st	49	CALB.E.st	81	AM2.st	113	PVE1.st	145	TIME9.st	177	RDI101.st
18	PV1BO.st	50		82		114	PVE2.st	146	TIME10.st	178	RDI102.st
19	RJC1ERR.st	51	USER.E.st	83		115	PVE3.st	147	TIME11.st	179	RDI103.st
20		52		84		116		148		180	RDI104.st
21	PV1+over.st	53	UPMD.st	85		117	PVE4.st	149	TIME12.st	181	RDI105.st
22	PV1-over.st	54	RANGE.st	86		118	PVE5.st	150	TIME13.st	182	RDI106.st
23		55	SETUP.st	87		119	PVE6.st	151	TIME14.st	183	RDI107.st
24		56		88		120		152		184	RDI108.st
25		57	PARA.E.st	89	CAS/LSP.st	121	PVE7.st	153	TIME15.st	185	RDI201.st
26		58	MODE.E.st	90		122	PVE8.st	154	TIME16.st	186	RDI202.st
27		59	FILE.E.st	91		123		155	WEND.st	187	RDI203.st
28		60		92		124		156		188	RDI204.st
29		61		93		125		157	PTEND.st	189	RDI205.st
30		62		94		126		158	PTEND3.st	190	RDI206.st
31	AT1ERR.st	63	SYSTEM.E.st	95	AT2.st	127		159	PTEND5.st	191	RDI207.st
32		64		96		128		160		192	RDI208.st

051201E.EPS



### NOTE

- When specifying an I relay number, use the number of [I relay number + 5000]. For example, to refer to the RJC1ERR.st relay (I relay No.: 9), specify 5009, which is 9 + 5000.
- In the area for I relays 1 to 720, the areas with no I relay code names are not in use. Do not write to or read from these unused I relay areas; doing so may damage the internal data of the UP750.

## 5.12.1 Area for Status I Relays

The configuration of status I relay area is as shown below.

I Relay No.	Category	Description
1 to 16	Status	Input error (same as D0001)
17 to 32		PV1 error (same as D0002)
33 to 48		PV2 error (same as D0018)
49 to 64		Error in calibration values or parameters (same as D0035)
65 to 80		Loop 1 mode (same as D0008)
81 to 96		Loop 2 mode (same as D0024)
97 to 112		Alarm status (same as D0011)
113 to 128		PV events 1 to 8 (same as D0012)
129 to 160		Time events 1 to 16 (same as D0013/14)
161 to 176		Status of external contact inputs (same as D0033)
177 to 192		Status of expanded external contact inputs (same as D0034)

051202E.EPS



### NOTE

- I relays 1 to 192 store status information. They are normally read for status information.
- When specifying an I relay number for communication, begin the number with the character "I." For example, set I0009 to specify the RJC1ERR.st relay (I relay No.: 9).

# 5.13 ON Status I Relays (I Relays 193 [5193] to 384 [5384])

## ■ Data Storage Area Map

ON-Status Area											
No.	I relay name	No.	I relay name	No.	I relay name	No.	I relay name	No.	I relay name	No.	I relay name
193	AD1ERR.on	225	PV2ADC.on	257	A/M1.on	289	ALM11.on	321	TIME1.on	353	DI1.on
194	AD2ERR.on	226	PV2BO.on	258		290	ALM12.on	322	TIME2.on	354	DI2.on
195	AD3ERR.on	227	RJC2ERR.on	259		291	ALM13.on	323	TIME3.on	355	DI3.on
196		228		260		292		324		356	DI4.on
197	AD1BO.on	229	PV2+over.on	261		293	ALM14.on	325	TIME4.on	357	DI5.on
198	AD2BO.on	230	PV2-over.on	262		294	OR1.on	326	TIME5.on	358	DI6.on
199	AD3BO.on	231		263		295		327	TIME6.on	359	DI7.on
200		232		264		296		328		360	
201	RJC1ERR.on	233		265	RESET.on	297		329	TIME7.on	361	DP1.on
202	RJC2ERR.on	234		266	PROG.on	298		330	TIME8.on	362	DP2.on
203		235		267	LOCAL.on	299		331		363	MG1.on
204		236		268		300		332		364	MG2.on
205		237		269	HOLD.on	301		333		365	MG3.on
206		238		270	WAIT.on	302	OR2.on	334		366	MG4.on
207		239	AT2ERR.on	271	AT1.on	303		335		367	
208		240		272		304		336		368	
209	PV1ADC.on	241	CALB.E.on	273	A/M2.on	305	PVE1.on	337	TIME9.on	369	RDI101.on
210	PV1BO.on	242		274		306	PVE2.on	338	TIME10.on	370	RDI102.on
211	RJC1ERR.on	243	USER.E.on	275		307	PVE3.on	339	TIME11.on	371	RDI103.on
212		244		276		308		340		372	RDI104.on
213	PV1+over.on	245	UTMD.on	277		309	PVE4.on	341	TIME12.on	373	RDI105.on
214	PV1-over.on	246	RANGE.on	278		310	PVE5.on	342	TIME13.on	374	RDI106.on
215		247	SETUP.on	279		311	PVE6.on	343	TIME14.on	375	RDI107.on
216		248		280		312		344		376	RDI108.on
217		249	PARA.E.on	281	CAS/LSP.on	313	PVE7.on	345	TIME15.on	377	RDI201.on
218		250	MODE.E.on	282		314	PVE8.on	346	TIME16.on	378	RDI202.on
219		251	FILE.E.on	283		315		347	WEND.on	379	RDI203.on
220		252		284		316		348		380	RDI204.on
221		253		285		317		349	PTEND.on	381	RDI205.on
222		254		286		318		350	PTEND3.on	382	RDI206.on
223	AT1ERR.on	255	SYSTEM.E.on	287	AT2.on	319		351	PTEND5.on	383	RDI207.on
224		256		288		320		352		384	RDI208.on

051301E.EPS



### NOTE

- When specifying an I relay number, use the number of [I relay number + 5000]. For example, to refer to the RJC1ERR.on relay (I relay No.: 201), specify 5201, which is 201 + 5000.
- In the area for I relays 1 to 720, the areas with no I relay code names are not in use. Do not write to or read from these unused I relay areas; doing so may damage the internal data of the UP750.



### 5.13.1 Area for ON Status I Relays

The configuration of ON Status I relay area is as shown below.

I Relay No.	Category	Description
193 to 208	ON status	Input error (same as D0001)
209 to 224		PV1 error (same as D0002)
225 to 240		PV2 error (same as D0018)
241 to 256		Error in calibration values or parameters (same as D0035)
257 to 272		Loop 1 mode (same as D0008)
273 to 288		Loop 2 mode (same as D0024)
289 to 304		Alarm status (same as D0011)
305 to 320		PV events 1 to 8 (same as D0012)
321 to 352		Time events 1 to 16 (same as D0013/14)
353 to 368		Status of external contact inputs (same as D0033)
369 to 384		Status of expanded external contact inputs (same as D0034)

051302E.EPS



**NOTE**

- The ON Status I relays 193 to 384 are turned on for one control period only when the status changes from “off ” to “on.”
- When specifying an I relay number for communication, begin the number with the character “I.” For example, set I0201 to specify the RJC1ERR.on relay (I relay No.: 201).

# 5.14 OFF Status I Relays (I Relays 385 [5385] to 576 [5576])

## ■ Data Storage Area Map

OFF-Status Area											
No.	I relay name	No.	I relay name	No.	I relay name	No.	I relay name	No.	I relay name	No.	I relay name
385	AD1ERR.off	417	PV2ADC.off	449	A/M1.off	481	ALM11.off	513	TIME1.off	545	DI1.off
386	AD2ERR.off	418	PV2BO.off	450		482	ALM12.off	514	TIME2.off	546	DI2.off
387	AD3ERR.off	419	RJC2ERR.off	451		483	ALM13.off	515	TIME3.off	547	DI3.off
388		420		452		484		516		548	DI4.off
389	AD1BO.off	421	PV2+over.off	453		485	ALM14.off	517	TIME4.off	549	DI5.off
390	AD2BO.off	422	PV2-over.off	454		486	OR1.off	518	TIME5.off	550	DI6.off
391	AD3BO.off	423		455		487		519	TIME6.off	551	DI7.off
392		424		456		488		520		552	
393	RJC1ERR.off	425		457	RESET.off	489		521	TIME7.off	553	DP1.off
394	RJC2ERR.off	426		458	PROG.off	490		522	TIME8.off	554	DP2.off
395		427		459	LOCAL.off	491		523		555	MG1.off
396		428		460		492		524		556	MG2.off
397		429		461	HOLD.off	493		525		557	MG3.off
398		430		462	WAIT.off	494	OR2.off	526		558	MG4.off
399		431	AT2ERR.off	463	AT1.off	495		527		559	
400		432		464		496		528		560	
401	PV1ADC.off	433	CALB.E.off	465	A/M2.off	497	PVE1.off	529	TIME9.off	561	RDI101.off
402	PV1BO.off	434		466		498	PVE2.off	530	TIME10.off	562	RDI102.off
403	RJC1ERR.off	435	USER.E.off	467		499	PVE3.off	531	TIME11.off	563	RDI103.off
404		436		468		500		532		564	RDI104.off
405	PV1+over.off	437	UPMD.off	469		501	PVE4.off	533	TIME12.off	565	RDI105.off
406	PV1-over.off	438	RANGE.off	470		502	PVE5.off	534	TIME13.off	566	RDI106.off
407		439	SETUP.off	471		503	PVE6.off	535	TIME14.off	567	RDI107.off
408		440		472		504		536		568	RDI108.off
409		441	PARA.E.off	473	CAS/LSP.off	505	PVE7.off	537	TIME15.off	569	RDI201.off
410		442	MODE.E.off	474		506	PVE8.off	538	TIME16.off	570	RDI202.off
411		443	FILE.E.off	475		507		539	WEND.off	571	RDI203.off
412		444		476		508		540		572	RDI204.off
413		445		477		509		541	PTEND.off	573	RDI205.off
414		446		478		510		542	PTEND3.off	574	RDI206.off
415	AT1ERR.off	447	SYSTEM.E.off	479	AT2.off	511		543	PTEND5.off	575	RDI207.off
416		448		480		512		544		576	RDI208.off

051401E.EPS



### NOTE

- When specifying an I relay number, use the number of [I relay number + 5000]. For example, to refer to the RJC1ERR.off relay (I relay No.: 393), specify 5393, which is 393 + 5000.
- In the area for I relays 1 to 720, the areas with no I relay code names are not in use. Do not write to or read from these unused I relay areas; doing so may damage the internal data of the UP750.

### 5.14.1 Area for OFF Status I Relays

The configuration of OFF Status I relay area is as shown below.

I Relay No.	Category	Description
385 to 400	OFF status	Input error (same as D0001)
401 to 416		PV1 error (same as D0002)
417 to 432		PV2 error (same as D0018)
433 to 448		Error in calibration values or parameters (same as D0035)
449 to 464		Loop 1 mode (same as D0008)
465 to 480		Loop 2 mode (same as D0024)
481 to 496		Alarm status (same as D0011)
497 to 512		PV events 1 to 8 (same as D0012)
513 to 544		Time events 1 to 16 (same as D0013/14)
545 to 560		Status of external contact inputs (same as D0033)
561 to 576		Status of expanded external contact inputs (same as D0034)

051402E.EPS



**NOTE**

- The OFF Status I relays 385 to 576 are turned on for one control period only when the status changes from “off ” to “on.”
- When specifying an I relay number for communication, begin the number with the character “I.” For example, set I0393 to specify the RJC1ERR.off relay (I relay No.: 393).

# 5.15 Status I Relays for Alarm Flag, Timer Flag, Power-on Flag, and Others (I Relays 577 [5577] to 2048 [7048])

## ■ Data Storage Area Map

Area for SP No., PID No., Timer Flag, Power-on Flag, and Alarm Flag, plus User Area											
No.	I relay name	No.	I relay name	No.	I relay name	No.	I relay name	No.	I relay name	No.	I relay name
577		609	PIDNO2.0.st	641	SEGNO.0.st	673	PV2.st	705	PVEO1.st	737	
578		610	PIDNO2.1.st	642	SEGNO.1.st	674		706	PVEO2.st	738	
579		611	PIDNO2.2.st	643	SEGNO.2.st	675		707	PVEO3.st	739	
580		612	PIDNO2.3.st	644	SEGNO.3.st	676		708		740	
581	/AUT/MAN1.st	613		645	SEGNO.4.st	677		709	PVEO4.st	741	
582		614		646	SEGNO.5.st	678		710	PVEO5.st	742	
583		615		647	SEGNO.6.st	679		711	PVEO6.st	743	
584		616		648		680		712		744	
585		617		649		681	DEV1-.st	713	PVEO7.st	745	
586		618		650		682	DEV1Z.st	714	PVEO8.st	746	
587	/RESET.st	619		651		683	DEV1+.st	715		747	
588	/PROG.st	620		652		684		716		748	
589	/LOCAL.st	621		653		685	DEV2-.st	717		749	
590	/HOLD.st	622		654		686	DEV2Z.st	718		750	
591	/WAIT.st	623		655		687	DEV2+.st	719		751	
592	/AT1.st	624		656		688		720		752	
593	PIDNO1.0.st	625	PTNO.0.st	657	TIM.1S.st	689	ALO11.st	721		753	
594	PIDNO1.1.st	626	PTNO.1.st	658	TIM.5S.st	690	ALO12.st	722		754	
595	PIDNO1.2.st	627	PTNO.2.st	659	TIM.10S.st	691	ALO13.st	723		755	
596	PIDNO1.3.st	628	PTNO.3.st	660		692		724		756	
597	/AUT/MAN2.st	629	PTNO.4.st	661	TIM.1M.st	693	ALO14.st	725		757	
598		630		662		694		726		758	
599	/CAS/LSP.st	631		663		695		727		759	
600	/AT2.st	632		664		696		728		760	
601		633		665		697		729		761	
602		634		666		698		730		762	
603		635		667		699		731		763	
604		636		668		700		732		764	
605		637		669		701		733		765	
606		638		670		702		734		766	
607		639		671		703		735		767	
608		640		672	PON.st	704		736		768	

051501E.EPS

I relays 721 through 2048 are the area where users can freely read or write.



### NOTE

- When specifying an I relay number, use the number of [I relay number + 5000]. For example, to refer to the TIM.1S relay (I relay No.: 657), specify 5657, which is 657 + 5000.
- In the area for I relays 1 to 720, the areas with no I relay code names are not in use. Do not write to or read from these unused I relay areas; doing so may damage the internal data of the UP750.

### 5.15.1 Status I Relays for Alarm Flag, Timer Flag, Power-on Flag, and Others

The following table summarizes how the status area (I relays) of flags, including alarm flag, timer flag, and power-on flag, is configured. I relays 577 to 720 store the on-off statuses of the SP number, PID number, timer flag, power-on flags, etc.

I Relay No.	Category	Description
577 to 592	Status	Loop 1 mode (inverse status)
593 to 596		Current loop 1 PID number (Note 1) (same as D0009)
597 to 600		Loop 2 mode (inverse status)
609 to 624		Current loop 2 PID number (Note 1) (same as D0025)
625 to 656		Current program pattern number (same as D0042)
657 to 672		1-second, 5-second, 10-second and 1-minute timers (Note 2)
673 to 688		Status of PV2, LP2, and deviation lamps (Note 3)
689 to 704		Status of alarm outputs (same as D0036)
705 to 720		Status of PV event outputs (same as D0049)

Note 1: The information of these I relays is represented by 4-digit binary codes, from 0000 (0 in decimal) to 1000 (8 in decimal), which are formed by the bit combination of four I relays. The lowest-numbered I relay in each set signifies the LSB.

Note 2: The 1-second, 5-second, 10-second and 1-minute timer functions are available with I relays only.

Note 3: This information represents the status of the UP750's front-panel lamps. The relay turns on (flag "1") when the lamp is lit.

051502E.EPS

#### TIP

- I relays 1 to 576 and 689 to 701 have the same bit information, both in terms of code and contents, as the D registers for read-only information.
- Refer to section 5.4.1, "Process Data Area (Read-only Data)" for a description.



#### NOTE

- When specifying an I relay number for communication, begin the number with the character "I." For example, set I0657 to specify TIM.IS (I relay No.: 657).

### 5.15.2 User Area

I Relay No.	Category	Description
721 to 2048	User area	You can read/write data from/to the area for I relays 721 to 2048 via communication. That is, you can use the area freely without affecting the control function of the UP750.

0501504E.EPS

### 5.15.3 Timer Function

A timer function that repeats ON/OFF action at a constant time interval is available using I relays. 1-second, 5-second, 10-second, and 1-minute timers are offered.

The following table shows the timer values and their corresponding I relay codes and numbers.

Timer value	Code	I Relay No.	Description
1 second	TIM.1S.st	657	Repeats 1-second ON state and 1-second OFF state.
5 seconds	TIM.5S.st	658	Repeats 5-second ON state and 5-second OFF state.
10 seconds	TIM.10S.st	659	Repeats 10-second ON state and 10-second OFF state.
1 minute	TIM.1M.st	661	Repeats 1-minute ON state and 1-minute OFF state.

051505E.EPS

When assigned to a contact output, a timer signal can be output to an external device. The timer I relay action is shown below.

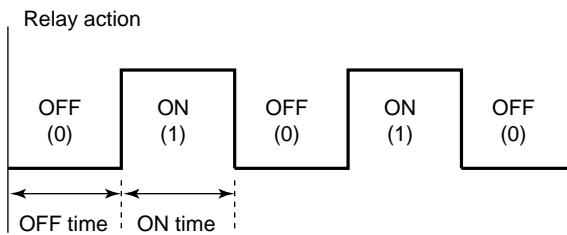

051506E.EPS

# 6. Operating Display Functions

Operating display functions are set up in the following three steps.

- [1] From the preset choices of operating displays, select the ones you want to show on the LCD display of the controller.

**See Also**

---

Section 6.1, "List of Operating Displays and Their Descriptions"

---

- [2] For each of the operating displays selected, set a non-displaying condition (may be given as a contact input signal or other).

**See Also**

---

Section 6.2, "Non-displaying Conditions for Operating Displays"

---

- [3] For each of the operating displays selected, set a display switching condition (may be given as a contact input signal or other) to forcibly switch to that operating display.

**See Also**

---

Section 6.3, "Display Switching Conditions for Operating Displays"

---

The following sections explain these topics.

For details about tool's operation, see the following.

**See Also**

---

Operating Display Function in LL200 PC-based Custom Custom Building Tool user's manual (IM 05G01B22-01E).

---

## 6.1 List of Operating Displays and Their Descriptions

For UP750, you can select any combination of up to 14 operating displays out of the 27 types of displays. Most of them are the operating displays used in standard UP modes.

For information about the display contents and functions of individual operation displays, see the following.

### See Also

---

Description of operating displays in UP750 User's Manual for Single-loop Control (IM 05E01B02-01E to -07E)

---

The subsequent pages will show a list of selectable operating displays together with their figures and names. Each of the displays indicates either a PV1 or PV2 value on the PV indicator (5-digit LED display).

Two of the operating displays are not used in standard UP modes: the "DISP display" and the "unilluminated operating display." The DISP display is used with computation modules DISP1 and/or DISP2 (No. 57, 58). Read the modules' explanations for how to use them. The unilluminated operating display shows nothing and, with this display, the PV indicator also shows nothing.

In an operating display that shows a control output value (OUT display, for example), the output value is normally displayed independently of the custom computation. Output values are always displayed in a range of 0 to 100%. In on/off control, 0% is shown when off, and 100% when on. In heating/cooling control, output values are displayed in a range of 0 to 100% for both on the heating side and cooling side. For information about the output distribution for the heating side and cooling side, see the following.

### See Also

---

Explanation of heating/cooling control in UP750 User's Manual for Single-loop Control (IM 05E01B02-01E to -07E)

---

The table in the subsequent pages lists the figure and names of the operating displays. On the LL200, these operating displays are identified by their pattern number (PTN no.). In the LL200 tool's screen, simplified views of the operating displays and the display contents on the PV indicator (PV, PV1, or PV2) are shown together with the pattern numbers.

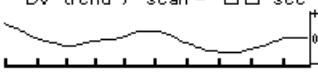
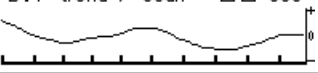
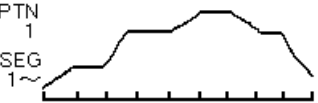
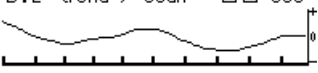
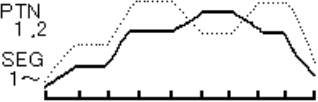

■ UP750 Operating Displays

PTN No.	Name	View	LED PV indicator	Remarks
1.	SP (LSP) display	<p>SP (LSP) : □□°C</p> <p>PTNO: □□□ SEGNO: □/□</p> <p>TM= □□h□□ RCY: □/□</p>	PV value	
2.	OUT display	<p>SP(LSP)=□□°C PID: □</p> <p>PTNO: □□□ SEGNO: □/□</p> <p>OUT : □□□ %</p>	PV value	
3.	Deviation trend display	<p>DV-trend / scan = □□ sec</p> 	PV value	
4.	Event display	<p>TME 1 2 14</p> <p>PVE 21 22 25</p> <p>ALM 1 4</p>	PV value	
5.	Heating/cooling OUT display	<p>SP(LSP)= □□°C PID : □</p> <p>C = □□□% H = □□□%</p> <p>Cool Heat</p>	PV value	
6.	SP1 (LSP1) display	<p>SP1(LSP1): □□°C</p> <p>PTNO: □□□ SEGNO: □/□</p> <p>TM= □□h□□ RCY: □/□</p>	PV1 value	
7.	Loop 1 Deviation trend display	<p>DV1-trend / scan = □□ sec</p> 	PV1 value	
8.	Pattern display	<p>PTN 1</p>  <p>SEG 1~</p>	PV1 value	For pattern-1
9.	LSP2 display	<p>LSP2: □□□°C</p> <p>PTNO: □□□ SEGNO: □/□</p> <p>TM= □□h□□ RCY: □/□</p>	PV1 value	
10.	Loop 2 Deviation trend display	<p>DV2-trend / scan = □□ sec</p> 	PV2 value	
11.	Pattern 1, 2 display	<p>PTN 1,2</p>  <p>SEG 1~</p>	PV1 value	For pattern-2
12.	Heating/cooling OUT2 display	<p>SP1(LSP1)=□□°C PID : □</p> <p>C2 = □□□% H2 = □□□%</p> <p>Cool 2 Heat 2</p>	PV1 value	
13.	PV2/SP/OUT2 display	<p>PV 2 = □□□°C</p> <p>SP1(LSP1)= □□°C PID 1 = □</p> <p>SP2(LSP2)= □□°C PID 2 = □</p> <p>OUT2= □□□%</p>	PV1 value	

060101E.EPS

PTN No.	Name	View	LED PV indicator	Remarks
14.	PV2/SP/TM/RCY display	PV 2 = □□□°C    PID : □ SP1(LSP1)= □□°C    PT : □□ SP2(LSP2)= □□°C    SEG : □□ TM = □□h□□    RCY : □□/□□	PV1 value	
15.	PV2/OUT1 display	PV2 = □□□°C PTNO: □□□    SEGNO : □/□ <b>OUT1 : □□□ %</b>	PV1 value	
16.	PV2/OUT2 display	PV2 = □□□°C PTNO: □□□    SEGNO : □/□ <b>OUT2 : □□□ %</b>	PV1 value	
17.	Heating/cooling PV2/OUT1 display	PV2 = □□□°C C1 = □□□%    H1 = □□□% <b>Cool 1    Heat 1</b>	PV1 value	
18.	Heating/cooling PV2/OUT2 display	PV2 = □□□°C C2 = □□□%    H2 = □□□% <b>Cool 2    Heat 2</b>	PV1 value	
19.	DISP display	DISP1 = □□□ DISP2 = □□□	PV1 value	Displays the data values of modules No. 57 and No. 58.
20.	Analog input display	AIN1 = □□□ AIN2 = □□□ AIN3 = □□□	PV value	
21.	SP/PTN/SEG/TM/RCY display	SP1(LSP1)= □□°C SP2(LSP2)= □□°C PTNO = □□    SEGNO = □□/□□ TM = □□h□□    REP = □□	PV1 value	
22.	Heating/cooling PV2/SP/OUT2 display	PV 2 = □□□°C SP1(LSP1)= □□°C    PID 1 = □ SP2(LSP2)= □□°C    PID 2 = □ C = □□□%    H = □□□%	PV1 value	
23.	Unilluminated operating display		No display	
24.	SP1/TSP1 display	S P 1 = □□□ . □□ / □□□ . □□  PTNO:□□    SEGNO:□□/□□ □□□□□□□□□□□□□□□□	PV value	
25.	SP1/TSP1/SP2/TSP2 display	S P 1 = □□□ . □□ / □□□ . □□ S P 2 = □□□ . □□ / □□□ . □□ PTNO:□□    SEGNO:□□/□□ □□□□□□□□□□□□□□□□	PV1 value	

060102E.EPS

## 6.2 Non-displaying Conditions for Operating Displays

You can set the following conditions for each of the operating displays selected for operating display.

### ■ UP750 Non-displaying Conditions for Operating Displays

No.	Code	Condition	Remarks
1	(None)	Displayed always.	
2	H/C	Not displayed upon heating/cooling control.	
3	NOT H/C	Displayed upon heating/cooling control.	
4	CAS	Not displayed in the CAS mode.	
5	LSP	Not displayed in the LSP mode.	When in internal cascade control
6	PT2.G=OFF	Display when Pattern 2 generator is on.	

060202E.EPS

## 6.3 Display Switching Conditions for Operating Displays

You can set the following conditions for each of the operating displays selected for operating display.

### ■ UP750 Display Switching Conditions for Operating Displays

No.	Code	Condition
1	AUTO1	Loop 1 is switched to the AUTO mode.
2	MAN1 $\wedge$ NOT H/C	Loop 1 is switched to the MAN mode, but not in heating/cooling control.
3	MAN1 $\wedge$ H/C	Loop 1 is switched to the MAN mode in heating/cooling control.
4	AUTO2	Loop 2 is switched to the AUTO mode.
5	MAN2 $\wedge$ NOT H/C	Loop 2 is switched to the MAN mode, but not in heating/cooling control.
6	MAN2 $\wedge$ H/C	Loop 2 is switched to the MAN mode in heating/cooling control.
7	CAS $\wedge$ NOT H/C	Switched to the CAS mode, but not in heating/cooling control.
8	CAS $\wedge$ H/C	Switched to the CAS mode in heating/cooling control.
9	LSP	Switched to the LSP mode.
10	AT1 on $\wedge$ NOT H/C	Loop 1 auto tuning is started, but not in heating/cooling control
11	AT1 on $\wedge$ H/C	Loop 1 auto tuning is started in heating/cooling control
12	AT2 on $\wedge$ NOT H/C	Loop 2 auto tuning is started, but not in heating/cooling control
13	AT2 on $\wedge$ H/C	Loop 2 auto tuning is started in heating/cooling control
14	DP1 on	DP1 = ON (*1)
15	DP2 on	DP2 = ON (*1)
16	PTN Key $\wedge$ CAS	PTN key is pressed in the CAS mode.
17	PTN Key $\wedge$ NOT CAS	PTN key is pressed in a mode other than the CAS mode.
18	LOCAL1	Loop 1 is switched to the LOCAL mode.
19	–	
20	–	
21	HOLD	Transferred to a HOLD state.
22	ADV	Segment advance is executed.
23	POWER ON	Power is turned on.

- \*1: The function to display a specific operating display when the contact input or flag assigned to the setup parameter DP1 or DP2 is turned on. To set up the on/off operation of DP1 and DP2, do either of the following.
- In the Contact Input Configuration screen of the parameters setting tool, assign a contact input among DI1 to DI7, RDI101 to 108, and RDI201 to 208 or an I relay number of an alarm status flag to DP1 and DP2.
  - By custom computation, connect any register you like to DP1 and DP2.

060301E.EPS



#### NOTE

Except for No.14, 15, and 23, display switching based on a mode change works only when the mode is changed by key operation. (The display will not be switched when the mode is changed by communication, external contact, or custom computation.)

---

# Revision Information

- Manual Title : Model LL200 PC-based Custom Computation Building Tool - User's Reference for UP750
- Manual No. : IM 05G01B22-03E

## **1st Edition/June 2000**

Newly published

## **2nd Edition/July 2000**

Error corrections and some descriptions added

## **3rd Edition/Jun 2003**

Correspondence Windows2000/XP

## **4th Edition/Jul 2004**

Product transfer to Yokogawa Electric Corporation

## **5th Edition/Sep 2004**

Error corrections.

## **6th Edition/Mar 2005**

Error corrections and some descriptions added

---

Written by Yokogawa Electric Corporation

Published by Yokogawa Electric Corporation  
2-9-32 Nakacho, Musashino-shi, Tokyo 180-8750, JAPAN

---

---

Blank Page



# YOKOGAWA

Yokogawa Electric Corporation

---

## YOKOGAWA ELECTRIC CORPORATION

### Network Solutions Business Division

2-9-32, Nakacho, Musashino-shi, Tokyo, 180-8750 JAPAN

Phone: +81-422-52-7179 Facsimile: +81-422-52-6793

### Sales Branch Offices

Tokyo, Nagoya, Osaka, Hiroshima, Fukuoka

---

## YOKOGAWA CORPORATION OF AMERICA

### Headquarters

2 Dart Road, Newnan, GA. 30265-1094 U.S.A.

Phone: +1-770-253-7000 Facsimile: +1-770-251-0928

Sales Branch Offices / Texas, Chicago, Detroit, San Jose

## YOKOGAWA EUROPE B. V.

### Headquarters

Databankweg 20, 3821 AL Amersfoort THE NETHERLANDS

Phone: +31-334-64-1611 Facsimile: +31-334-64-1610

Sales Branch Offices / Houten (The Netherlands), Wien (Austria), Zaventem

(Belgium), Ratingen (Germany), Madrid (Spain), Bratislava (Slovakia), Runcorn (United Kingdom), Milano (Italy), Vélizy Villacoublay (France), Johannesburg (Republic of South Africa)

## YOKOGAWA AMERICA DO SUL S.A.

### Headquarters & Plant

Praca Acapulco, 31-Santo Amaro, Sao Paulo/SP, BRAZIL CEP-04675-190

Phone: +55-11-5681-2400 Facsimile: +55-11-5681-4434

## YOKOGAWA ENGINEERING ASIA PTE. LTD.

### Head office

5 Bedok South Road, Singapore 469270 SINGAPORE

Phone: +65-6241-9933 Facsimile: +65-6241-2606

## YOKOGAWA ELECTRIC KOREA CO., LTD.

### Seoul Sales office

395-70, Shindaebang-dong, Dongjak-gu, Seoul, 156-010, KOREA

Phone: +82-2-3284-3000 Facsimile: +82-2-3284-3019

## YOKOGAWA TAIWAN CORPORATION

### Head office

17F, No.39, Sec. 1, Chung Hwa Road Taipei, 100 TAIWAN

Phone: +886-2-2314-9166 Facsimile: +886-2-2314-9918

## YOKOGAWA AUSTRALIA PTY. LTD.

### Head office

Centre Court D1, 25-27 Paul Street North, North Ryde, N. S. W. 2113, AUSTRALIA

Phone: +61-2-9805-0699 Facsimile: +61-2-9888-1844

## YOKOGAWA INDIA LTD.

### Head office

40/4 Lavelle Road, Bangalore, 560 001, INDIA

Phone: +91-80-227-1513 Facsimile: +91-80-227-4270

## LTD. YOKOGAWA ELECTRIC

Grokholskiy per. 13, Build. 2, 4th Floor, 129010, Moscow, RUSSIA FEDERATION

Phone: +7-095-737-7868 Facsimile: +7-095-737-7869

---